

ADVENTURES OF LOLO

Strategy Guide

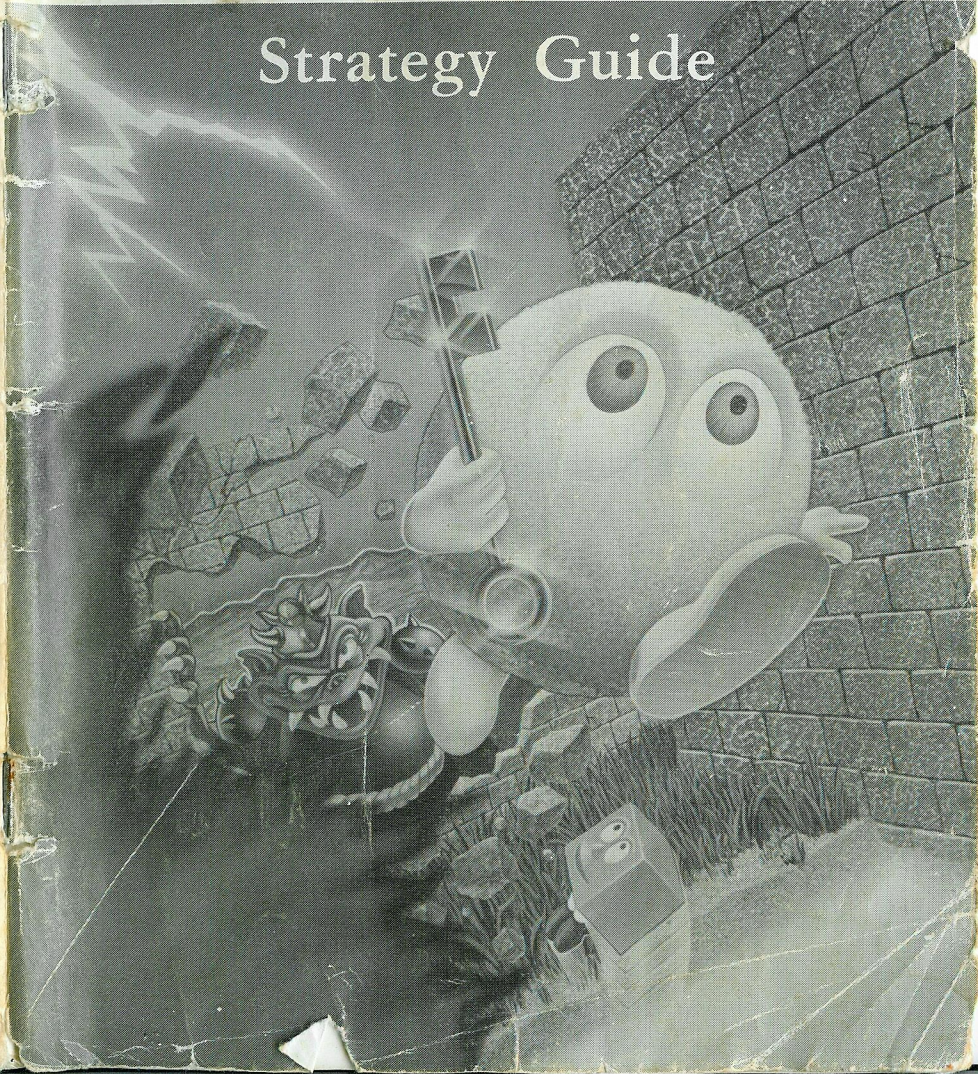

HAL AMERICA INCORPORATED

TEL. (503)644-4117

7873 SW Cirrus Dr., 25-F Beaverton, OR 97005

Printed in Japan



This game is licensed by Nintendo for play on the



Nintendo® and Nintendo Entertainment System® are trademarks of Nintendo of America Inc.

CARE OF YOUR GAME

- 1) Always make sure the power is off when inserting or removing the game pak from your computer.
- 2) This is a high precision game pak. Avoid subjecting it to extreme temperatures or shock. Store at room temperature. Never attempt to dismantle or open the game pak.
- 3) Do not touch the terminal leads or allow them to come in contact with water or the game circuitry will be damaged.
- 4) Never insert your fingers or any metal objects into the terminal portion of the computer. This can result in malfunction or damage.

THANK YOU

for selecting this exciting new game from HAL AMERICA, INC., "HAL". Please read this instruction booklet to ensure proper handling of your new game, and then save the booklet for future reference.

CONTENTS

THE STORY	2
CHARACTERS	2
HOW TO PLAY THE GAME	4
HOW TO USE THE CONTROLLER	5
ITEMS	6
ENVIRONMENT	7
HOW TO EARN POINTS	8
EXPLANATION OF THE ABBREVIATIONS	10
STRATEGY GUIDE	10

THE STORY

To save the country of Eden from the Great Devil's destruction the King of Eden dispatched Princess LALA to seek help. Prince LOLO was requested to accompany LALA back to Eden. On the way back The Great Devil kidnapped LALA right in front of LOLO.

To save Eden and rescue LALA, Prince LOLO went to the Devil's Haunted Castle. LOLO is not blessed with strength or agility but possesses great courage, high IQ and a lot of patience. Can LOLO save LALA after solving an almost endless series of mazes?

CHARACTERS

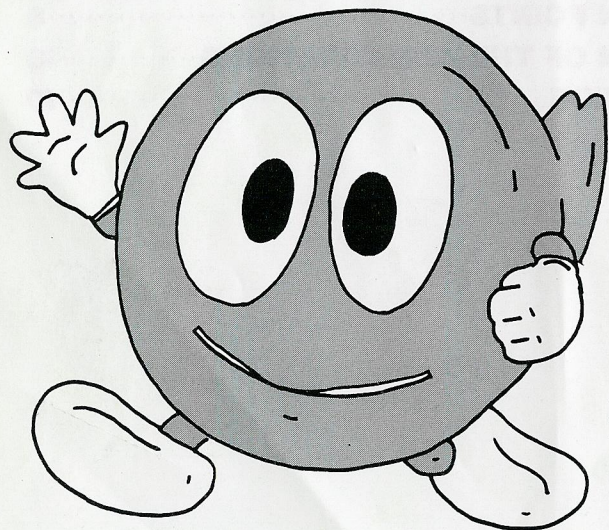

LOLO

The hero of this game. A brave prince who fights monsters.

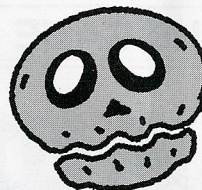

SKULL

When all the Heart Framers are taken, SKULL will awaken and begin to chase LOLO.

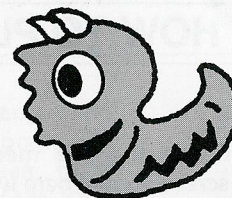

SNAKEY

A helpful harmless monster.

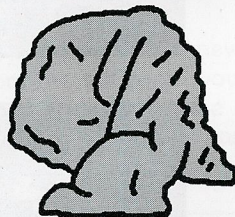

ALMA

When coming to LOLO's side, he will roll and dash against LOLO.

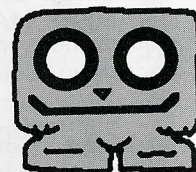

ROCKY

When faced with LOLO, he will dash forward to pin him down.

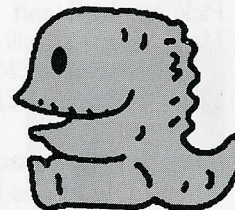

GOL

GOL awakes when all Heart Framers are taken, and discharges a flame when LOLO passes in front of him.

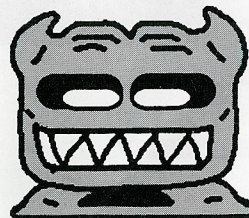

DON MEDUSA

He throws the Evil Eye and moves around within a limited range.

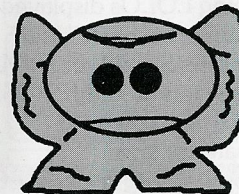

LEEPER

LEEPER will fall asleep after bumping into LOLO.

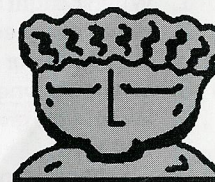

MEDUSA

When LOLO comes near, he will throw the Evil Eye.

HOW TO PLAY THE GAME

Game start

Select START on the title menu, then press START. The screen shown here will appear. Press START again to begin the game.

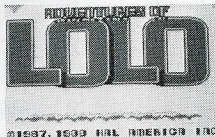

Picking up the Heart Framers

Pick up the Heart Framers by moving LOLO. Many monsters will block LOLO's way. Confine them by using the EMERALD FRAMERS, MAGIC SHOTS and POWER OPTIONS.

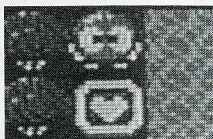

Clearing the Room

When LOLO takes all the Heart Framers on the screen, a Jewel Box will open containing a Jewel. Removing the Jewel clears the room. The Castle of the Labyrinth has trees, rocks, flower beds, deserts, and bodies of water. For their characters, refer to the reverse side of the Operating Manual.

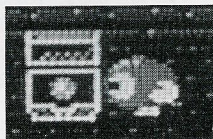

Game over

If any of the following occurs, one LOLO will be lost and the number of remaining LOLOs displayed at the screen's upper right corner will be reduced.

1. When caught by monsters SKULL or ALMA.
2. When attacked by monsters DON MEDUSA, MEDUSA, or GOL.
3. When drowned in water or lava.
4. When you give up by pressing the SELECT button.

The game is over when all LOLOs are lost.

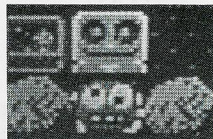

When the game is over, the screen changes and LOLO will show a CONTINUE prompt. To continue the game on the same screen, press START. To end the game, move LOLO to END using the control pad and press START. The game-over screen will be saved. The next game may be started on the same screen or by selecting a cleared screen.

Game continue

Instead of starting a new game, you can continue from the last room you cleared, using the password option. Use the control pad to select the proper letters for the password.

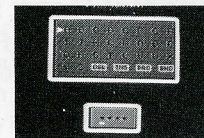

HOW TO USE THE CONTROLLER

Used to move LOLO vertically and horizontally.

Used to take advantage of MAGIC SHOTS or POWER.

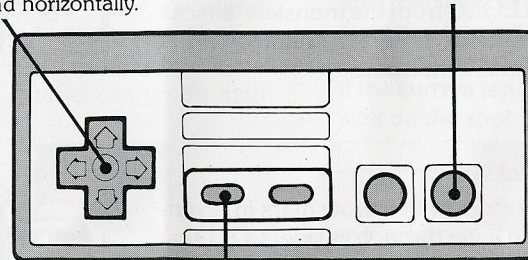

Used to give up the game.

When you come to a deadlock or notice wrong actions halfway, press SELECT. The game is given up, but you can challenge it again.

ITEMS

Heart Framers

Heart-marked blocks represent Heart Framers. When all Heart Framers in the room are taken the Jewel Box opens showing a Jewel. The Heart Framers protect LOLO from the monsters' attacks (MEDUSA's Evil Eye or flame-throwing GOL). Heart Framers cannot be moved.

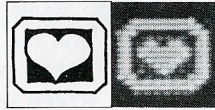

Special Heart Framers

The Special Heart Framers have a hidden infinite power. By taking one, you can gain two Magic Shots.

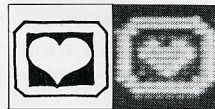

Emerald Framers

The green Emerald Framers can be moved by pushing them. Like Heart Framers, Emerald Framers protect LOLO from the monsters' attacks. Unlike Heart Framers, Emerald Framers can be moved to contain the monsters.

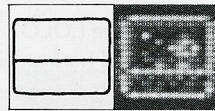

One-Way Passes

LOLO can not pass over the arrow mark in reverse direction, but can enter through its side. LOLO can pass over the mark pushing an Emerald Framer or an Egg. The direction of the arrow can be changed using POWER. Monsters can move in any direction regardless of the One-way Pass.

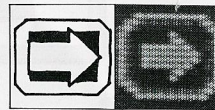

ENVIRONMENT

Flower Beds

LOLO can seek safety from the Monsters in the FLOWER BEDS, but they will wait and pounce on LOLO when he leaves the FLOWER BEDS.

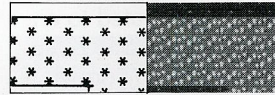

Lava

EGGS can not be floated over LAVA. LOLO can pass over it using the POWER of a BRIDGE. He must hurry, or the BRIDGE may burn down from the heat.

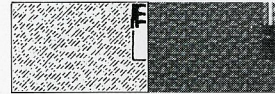

Trees

LOLO or active Monsters cannot pass through the trees. Neither can a MAGIC SHOT, but some Monsters' attacks can go through the trees.



Bridges

LOLO and the Monsters may cross BRIDGES at any time.

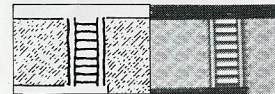

Deserts

LOLO can enter DESERTS freely, but his walking speed will be cut in half.

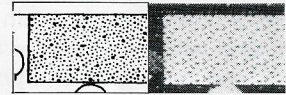

Rocks

Neither MAGIC SHOTS, Monsters' attacks, LOLO nor active Monsters can pass through a rock, but you can destroy the rock by using the power of the Hammer.

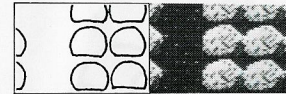

Rivers

LOLO is able to keep EGGS afloat and ride them on the water. If the current is flowing, then LOLO will be able to cross the river. However, if the current is not flowing, he will sink on the spot.

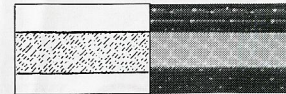

HOW TO EARN POINTS

MAGIC SHOTS

Magic Shots become available when certain Heart Framers are taken. A monster hit with a Magic Shot turns into an Egg. The Egg can be pushed around, but it will revert to its original shape and position after a period of time. When a monster is shot with two Magic Shots, the Egg flies out of the screen and will not return for a while. After a period of time, it will reappear in its original form and position. The Egg may be floated to enable LOLO to cross rivers and seas. Water flows only in specific directions. If there is no water flow, the Egg will sink and LOLO will drown if he is on board.

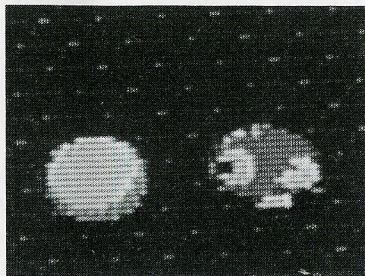
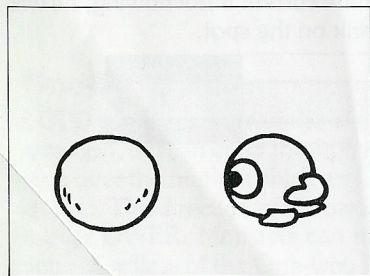
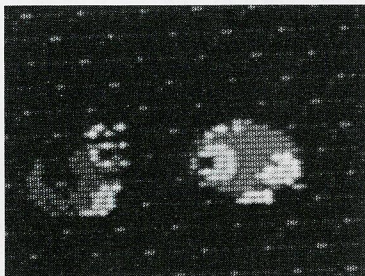
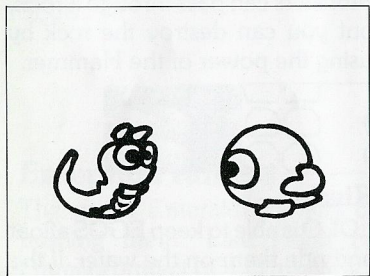

POWER

When one of the marks shown below appears on the Power Display, the indicated power may be used, but only after a Special Heart Framer has been taken. Magic Shots are not available when POWER is used.

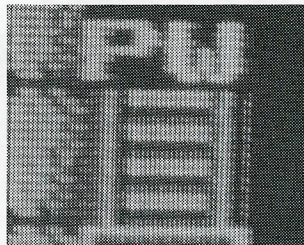

Bridge

A bridge can be spanned using Button A. Cross narrow rivers this way.

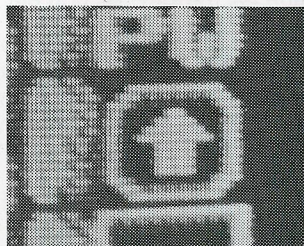

One-way Pass

The direction of a one-way pass can be changed by pressing Button A while facing the arrow mark.

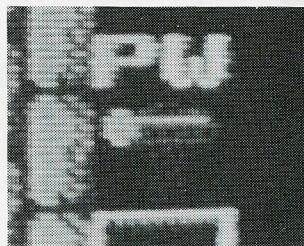

Hammer

A hindering rock can be destroyed by aiming at the rock and pressing A.

EXPLANATION OF THE ABBREVIATIONS

In order to use the space in this Strategy Guide wisely, we have used the following abbreviations. We are confident that they will cause no confusion if you have read the Manual.

HF Heart Framer
 HF's Heart Framers
 EF Emerald Framer
 EF's Emerald Framers
 MSs Magic Shots

STRATEGY GUIDE

Well, you've decided to tackle the Castle of the Labyrinth. There are many ways to clear each room, but if you get to a room you can't figure out, this Strategy Guide can help you out.

This Guide will show you one way to get through each room. As you get more familiar with the way each adversary behaves and the ways to use the tools at your disposal, you will find other strategies you can use. Don't be afraid to experiment.

- All directions are given from the player's point of view. So, for example, if the instructions say to move left, it means to your left as you face the screen, no matter what direction Lolo may be facing at the moment.
- The items in the diagrams will be marked A, B, etc., but in the same room you might have Emerald Framer A, Heart Framer A, Snakey A, and so on, so be sure you know what each character is called.
- Medusa and Don Medusa can attack you from a distance, so keep an eye on their paths at all times.
- There will be rooms where speed and agility are the key, and rooms where you can take your time. You'll learn to tell the difference with practice.
- There will be sections of the game where timing is crucial. With a bit of practice you'll know where those points are.

Floor 1-1

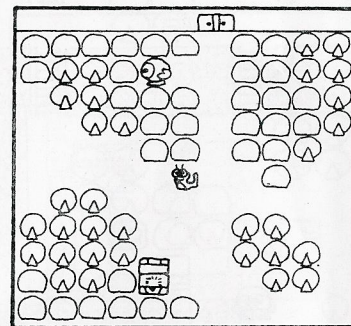

(Fig. 3)

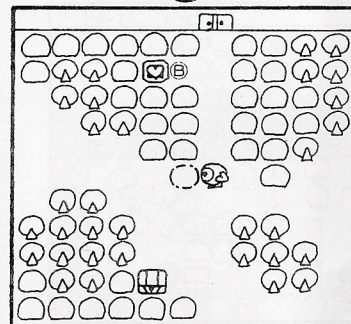
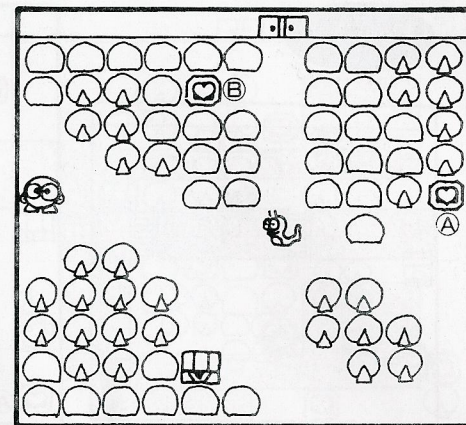

(Fig. 2)

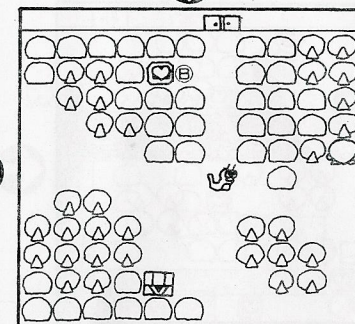

(Fig. 1)

1. The long journey has begun! The first Monster you will meet is Snakey. We'll show you how to get around him in a moment. First take HF A. (Fig. 1)
2. Once you take the HF you will get two Magic Shots. Use your first shot to encase Snakey in an Egg, and your second to bounce him out of the screen. (Fig. 2)
3. When you take the second HF the Jewel Box will open. (Fig. 3) When you take the Jewel Snakey will disappear and the door will open. You've cleared your first room. There are many, more difficult ones to come.

Floor 1-2

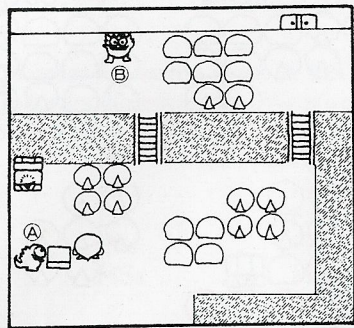

(Fig. 3)

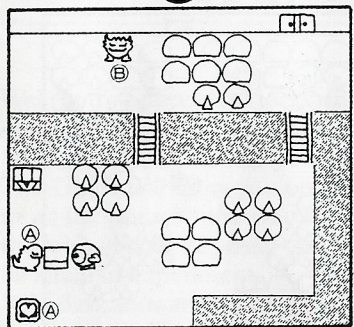

(Fig. 2)

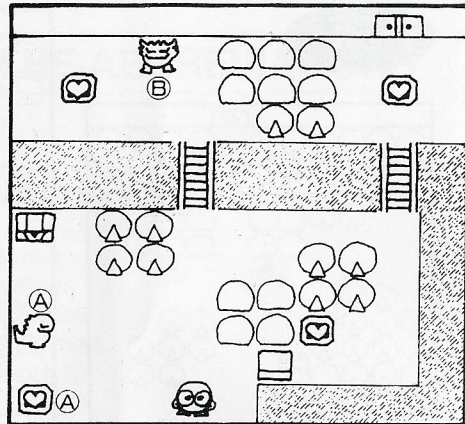

(Fig. 1)

1. Gol will remain asleep until all the HF's are taken. Leaving HF A, take all the rest of the HF's. (Fig. 1)
2. Move the EF over in front of Gol. It can be difficult to correct a mistake in moving an EF, so be accurate. (Fig. 2)
3. Take HF A. Gol will wake up, but you've blocked him in with the EF, so there's nothing to fear from him. But Gol B can throw flames from above, so you'll have to avoid his flames on your way to the Jewel Box. (Fig. 3)

Floor 1-3

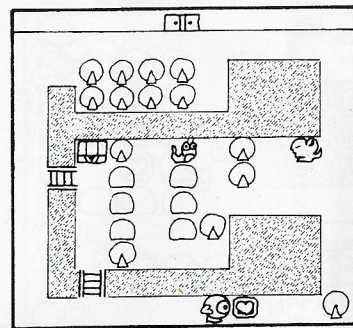

(Fig. 3)

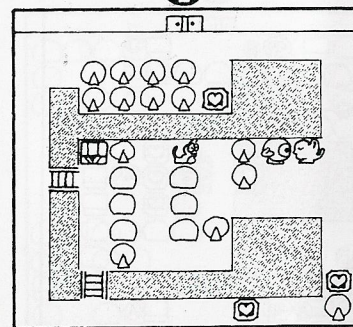

(Fig. 2)

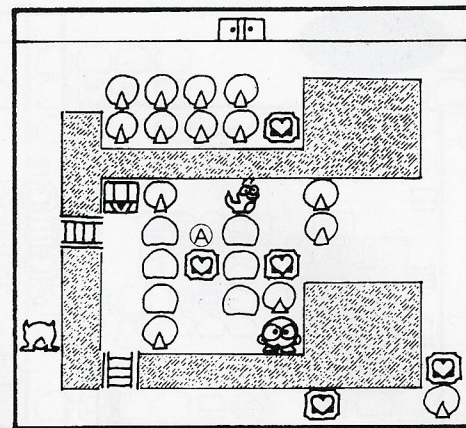

(Fig. 1)

1. When you take HF A you will get the use of two MS's. Use your first MS to encase Snakey in an Egg, and your second to bounce him out of the screen. (Fig. 1)
2. When Leeper touches Lolo he falls asleep and you won't be able to move him. Don't put him to sleep in a narrow spot or you'll trap yourself. Wait for him in the spot shown in the diagram. (Fig. 2)
3. Now you can pick up the rest of the HF's, take the Jewel, and you're off to the next room! (Fig. 3)

Floor 1-4

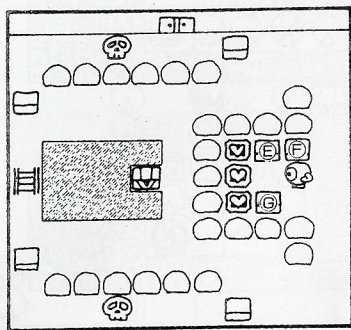

(Fig. 3)

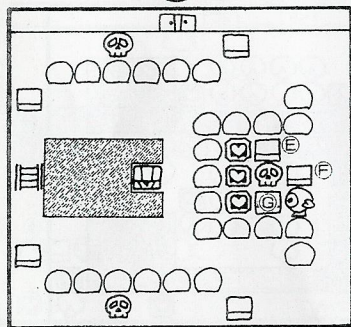

(Fig. 2)

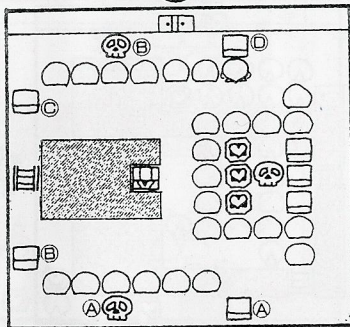

(Fig. 1)

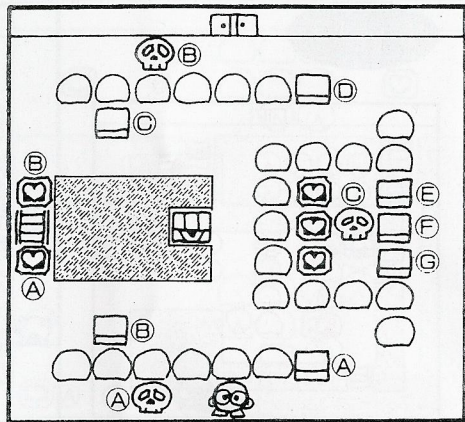
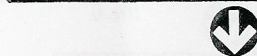

1. In this room you'll have to confine all the Skulls before you take the last HF. First move EF A down and EF B to the left, trapping Skull A. Take HFs A and B, then use EFs C and D to confine Skull B. (Fig. 1)
2. Move EFs E and G to the left, and push EF F up. (Fig. 2)
3. Use two MSs to remove Skull C from the screen. (Fig. 3) When you take the rest of the HFs the Skulls will be free to move, but if you've successfully blocked them in you'll be safe. Skull C will reappear, so don't waste any time!

Floor 1-5

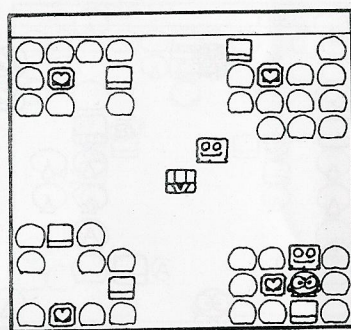

(Fig. 3)

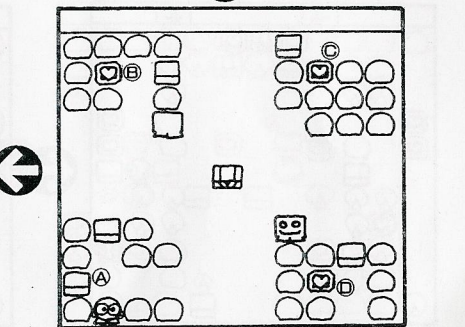

(Fig. 1)

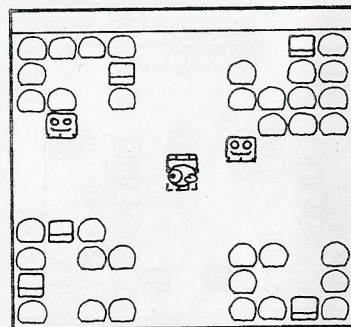

(Fig. 2)

1. Push EF A over to the left wall, and take HF A. (Fig. 1)
2. You can take HF B without moving the EF. To get to HFs C and D you'll have to move the EFs that are in the way. There's only one way in and out, so don't let Rocky block you in! (Fig. 2)
3. Rocky will do his best to block you in, so keep an eye on him, especially when you're among the rocks. (Fig. 3) When you've cleared the room a staircase will appear. Climb the staircase, and you're off to the second floor!

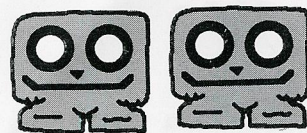

Floor 2-1

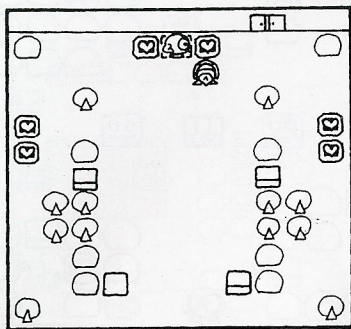

(Fig. 3)

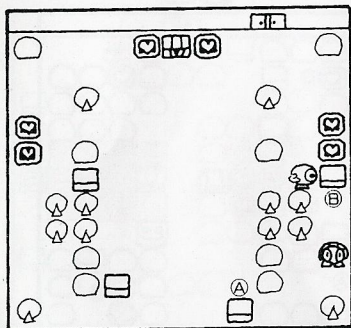
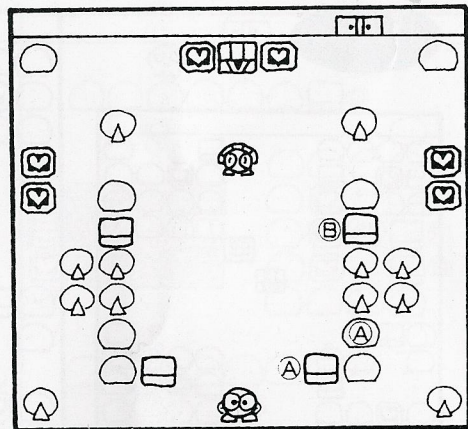

(Fig. 2)

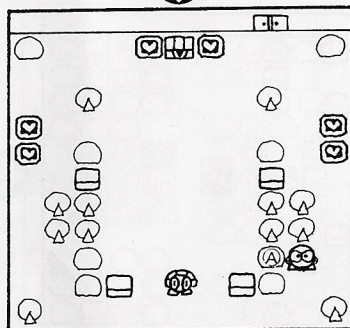

(Fig. 1)

1. Alma ordinarily moves at a constant speed, but he also can tuck his body into a ball and roll quickly after Lolo. When he does this he moves in a predictable pattern that you can use to your advantage once you understand it. First, move quickly to the side of Rock A and wait. (Fig. 1)
2. Go immediately to the bottom of the screen and move EF A down. When Alma moves down, push EF B to the right and trap him. (Fig. 2)
3. If you do this successfully you can take the rest of the HFs and clear the room. (Fig. 3)

Floor 2-2

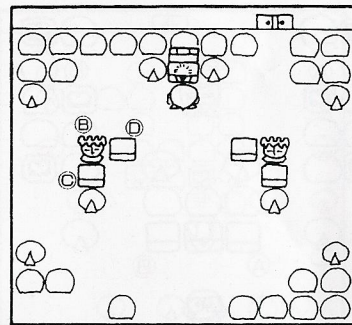

(Fig. 3)

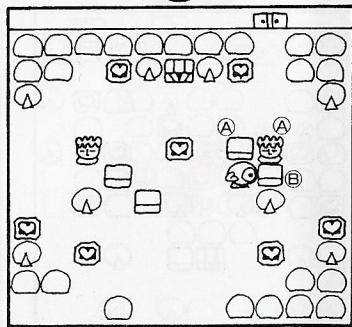

(Fig. 2)

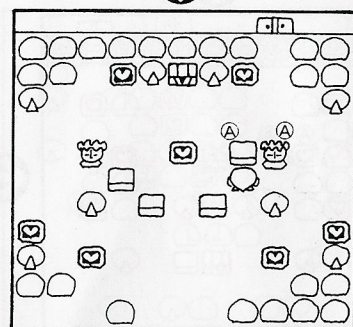
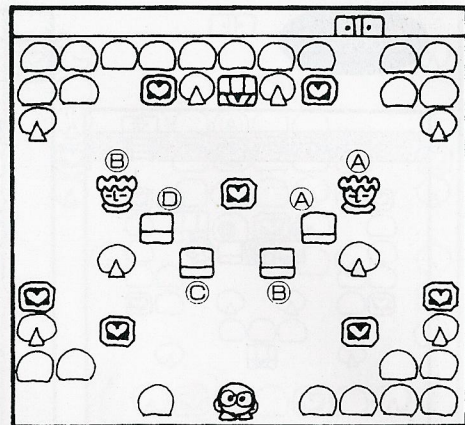

(Fig. 1)

1. Move EF A up to block Medusa's Evil Eye on the left. (Fig. 1)
2. Move EF B up and to the right to block his downward line of sight. (Fig. 2)
3. Use EFs C and D to block off Medusa B in the same way. Now you can take the rest of the HFs. (Fig. 3) Medusa is still dangerous, so be careful!

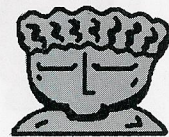

Floor 2-3

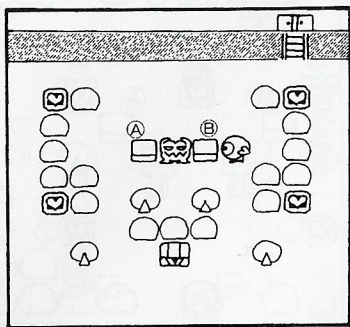

(Fig.3)

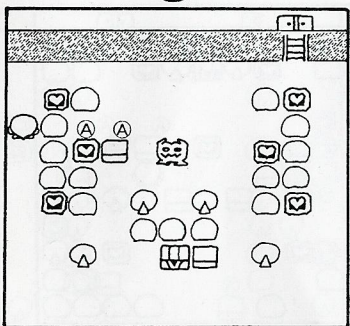
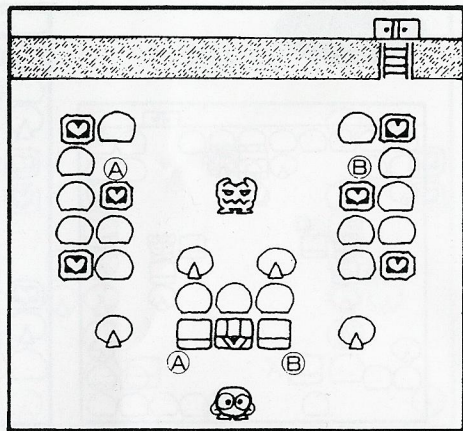

(Fig.2)

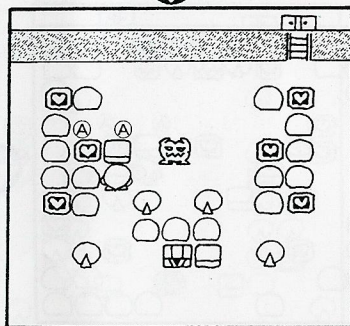

(Fig.1)



1. Move Lolo up into the Jewel Box, and push EF A to the left as far as the tree. Watch your timing, and put the EF directly in Don Medusa's path. (Fig. 1)
2. Go up the left wall and pick up HF A. Be careful of Don Medusa! (Fig. 2) Then move EF A one space to the right.
3. Now move to the right side and perform the same maneuver, picking up HF B. Move EF B to the left and block Don Medusa. Now you can pick up the rest of the HFs. (Fig. 3)

Floor 2-4

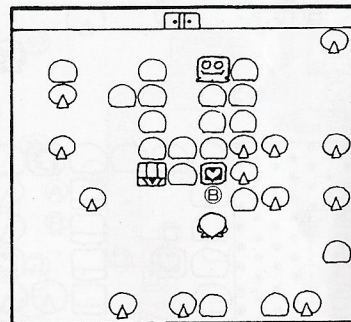

(Fig.3)

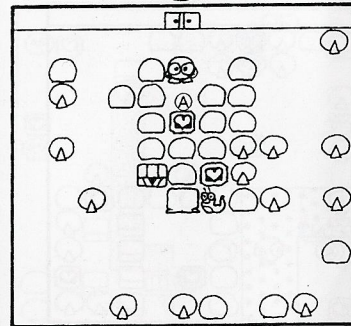
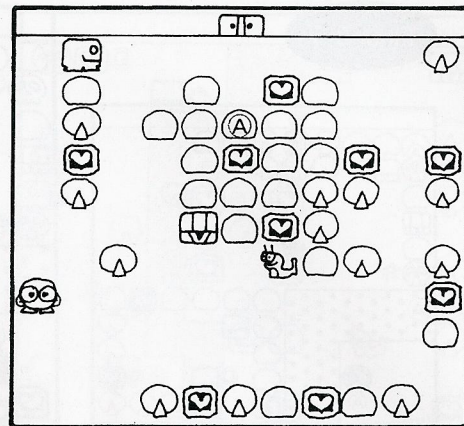

(Fig.2)

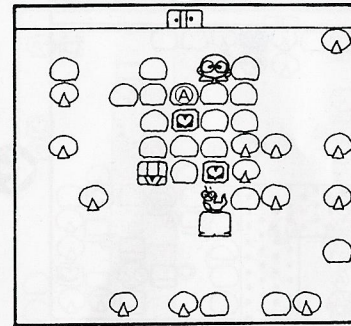

(Fig.1)



1. Pick up all the HFs you can, but keep an eye on Rocky's movements. (Fig. 1)
2. The Hammer will start to flicker in the Power Display. Use your Hammer Power to shatter Rock A. (Fig. 2)
3. Watch Rocky's movements carefully, and take HF A. Use the two MSs you now have to get rid of Snakey. Now you can pick up HF B and clear the room. (Fig. 3)



Floor 2-5

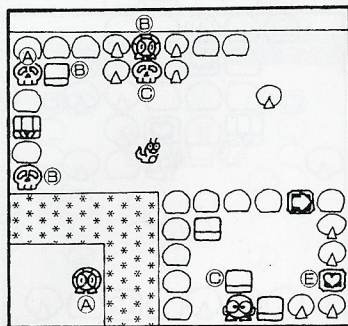

(Fig. 3)

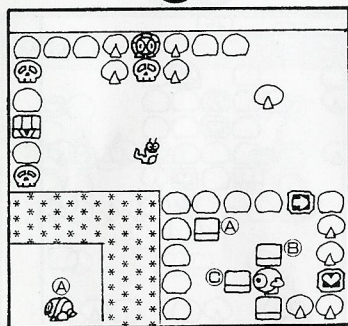
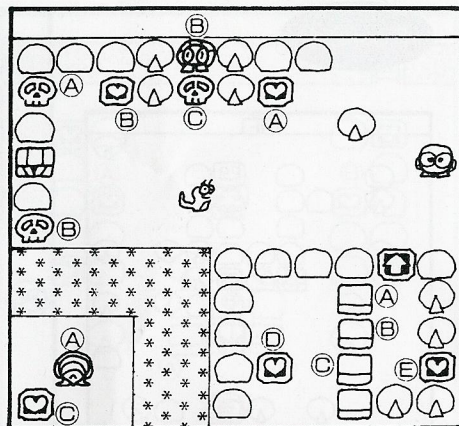

(Fig. 2)

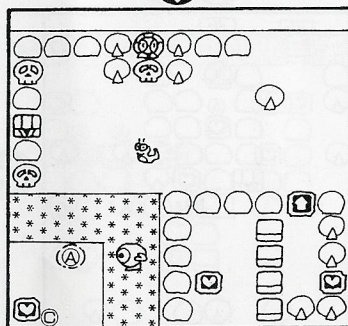

(Fig. 1)

1. Take HFs A and B, then go to the Flower Bed and wait. Timing your shot carefully, encase Alma in an Egg and take HF C. (Fig. 1)
2. Now change the direction of the One-Way Pass. Move EF A all the way to the left and take HF D. Then move EF C one space to the left. (Fig. 2)
3. Now move EFs B and C out and trap Skulls A and B. (Fig. 3) Encase Snakey in an Egg and use it to trap Skull C. Take HF E, pick up the Jewel, and you're off to the Third Floor!

Floor 3-1

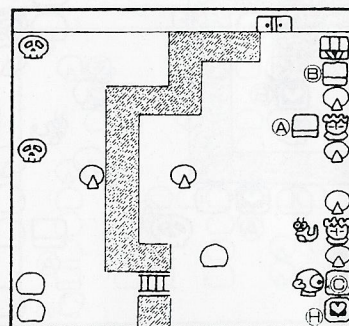

(Fig. 3)

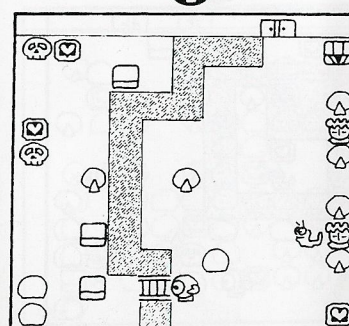
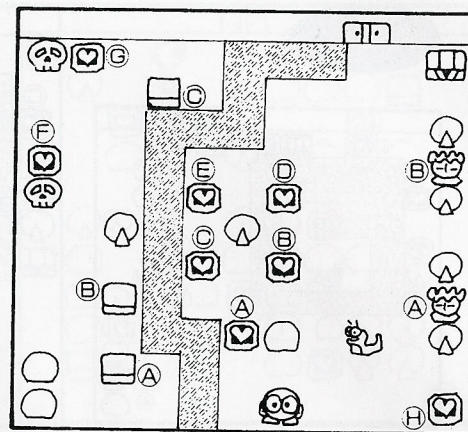

(Fig. 2)

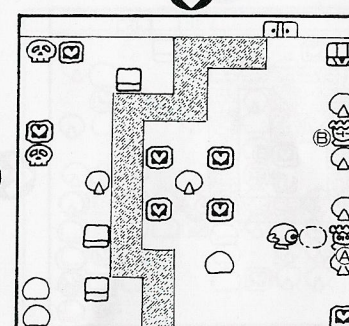

(Fig. 1)

1. Taking HF A will give you two MSs. Use one to encase Snakey, and use the Egg to block the horizontal line of sight of Medusa A. (Fig. 1)
2. Take HFs B, C, D and E, then build a Bridge at the point shown in the diagram. (Fig. 2)
3. Use EFs A and B to block Medusa B on the side and top. Take HFs F and G, then use EF C to block Medusa A's downward line of sight. (Fig. 3) When you take HF H the Skulls will start their pursuit, so hurry to the Jewel Box and take the Jewel.

Floor 3-2

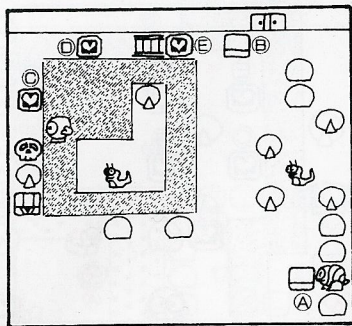

(Fig. 3)

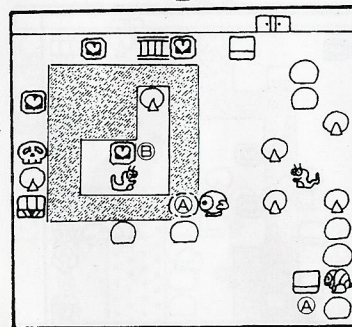
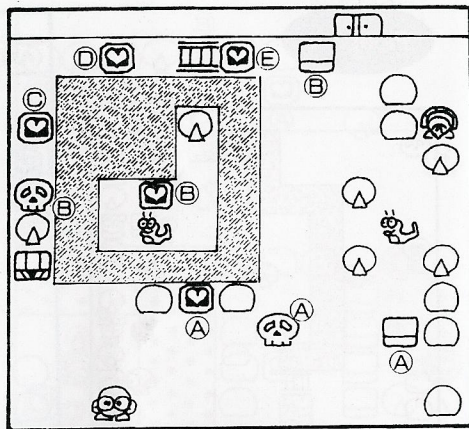

(Fig. 2)

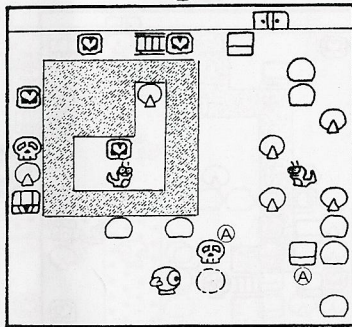

(Fig. 1)

1. First take HF A. Then, positioning Lolo as shown in the diagram, use one of your MSs to encase Alma in an Egg. (Fig. 1)
2. Push the Egg in between the rocks on the right, and use EF A to block it in. Use your second MS to encase Skull. Then push the Egg up and float it on the water. (Fig. 2)
3. Use the Egg to cross over to the island. Take HF B, then catch the Egg again as it floats by. (Fig. 3) Landing just above Skull, take HFs C and D. Skull will immediately start to chase Lolo, so hurry to the Jewel box. Remember, Skull A will soon reappear, so don't waste any time!

Floor 3-3

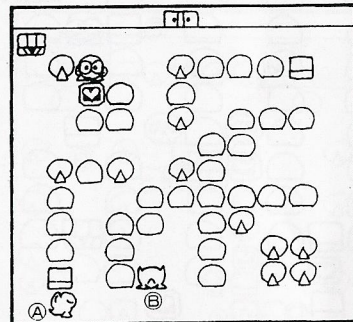

(Fig. 3)

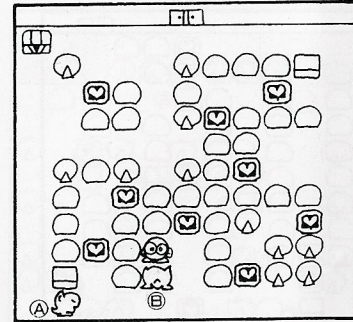
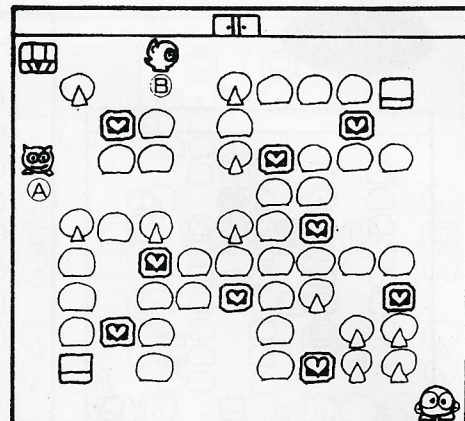

(Fig. 2)

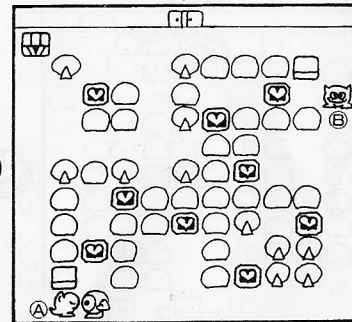

(Fig. 1)

1. First, move Lolo to the left and put Leeper to sleep in the spot shown in the diagram. (Fig. 1)
2. Now go to the spot shown in the diagram, and put Leeper B to sleep. (Fig. 2)
3. Now you can take your time picking up the HFs. (Fig. 3) Just be careful where you put the Leepers to sleep-don't trap yourself.

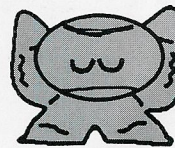
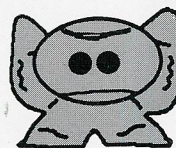

Floor 3-4

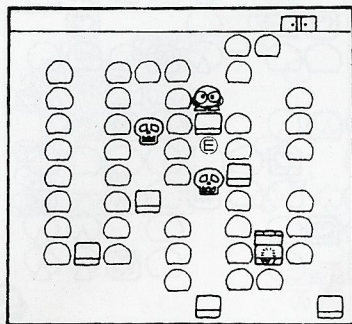

(Fig.3)

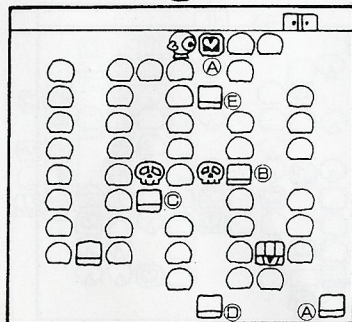
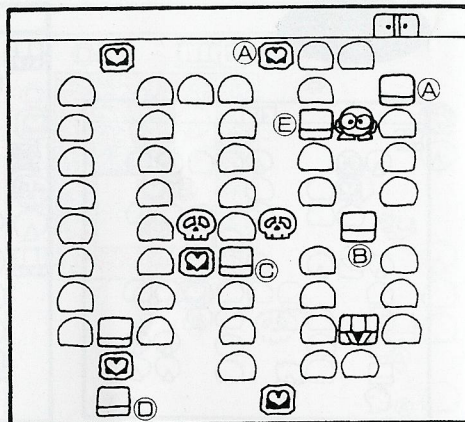

(Fig.2)

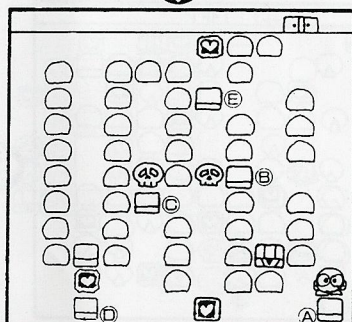

(Fig.1)

1. Move EF E to the left, and EF A to the right. Following the wall down, move EF B to the left. (Fig. 1)
2. Move EF C to the left, and EF D four spaces to the right. Along the way you can pick up all the HFs except HF A. (Fig. 2)
3. Now you can take HF A. The Monsters will start to move, but you're in no danger. Push EF E and Skull down together, and take the Jewel. (Fig. 3)

Floor 3-5

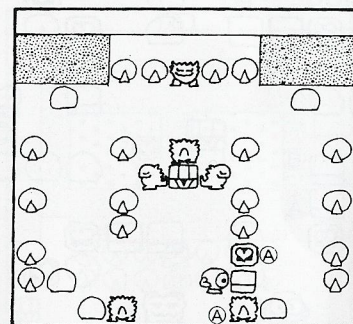

(Fig.3)

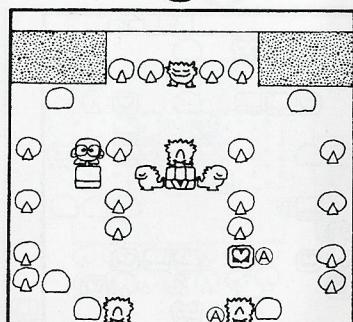
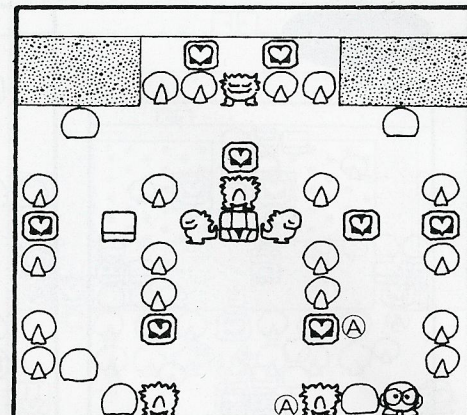

(Fig.2)

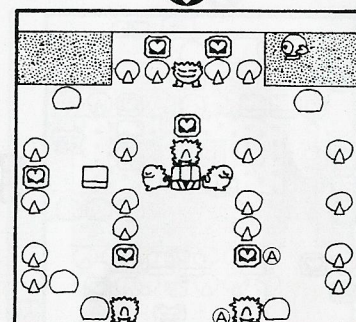

(Fig.1)

1. First take all the HFs except HF A. The Desert will slow Lolo down, but you're in no danger yet. (Fig. 1)
2. Once you've taken the HFs, move over to the EF. (Fig. 2)
3. Move the EF to the space between Gol A and HF A. (Fig. 3) Now you can take HF A, and the Jewel. Off to the Fourth Floor!

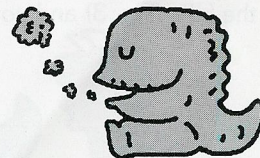

Floor 4-1

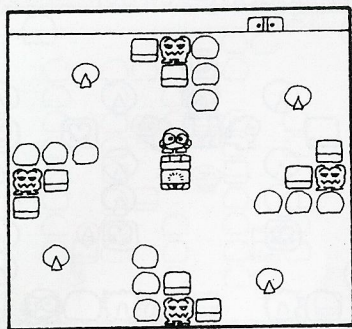

(Fig. 3)

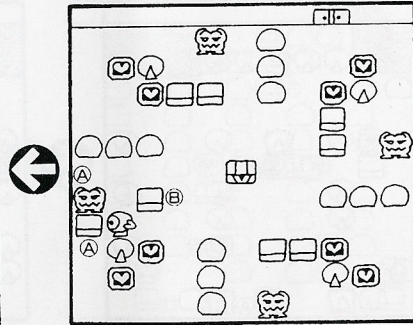
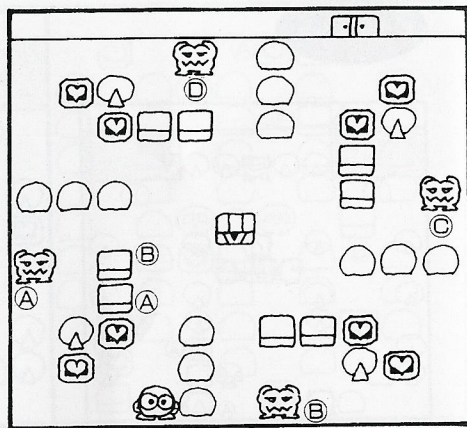

(Fig. 1)

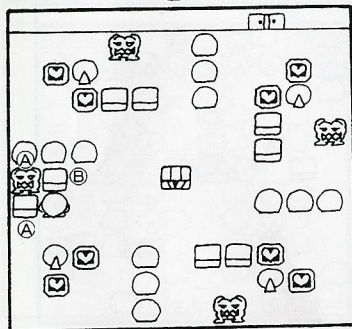

(Fig. 2)



1. Move up to the right side of EF A and wait. Timing your move carefully, use the EF to trap Don Medusa between the EF and the rock. (Fig. 1)
2. Circle around and push EF A up to complete your trap. Then use EF B up to block him on the right. (Fig. 2)
3. Move to the right, using only safe areas, and trap Don Medusa B in the same way. Use the same technique to trap Don Medusas C and D. Take the HFs (Fig. 3) and you're off to the next challenge!

Floor 4-2

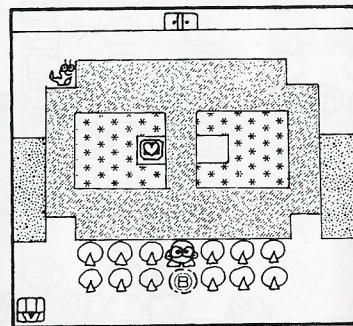

(Fig. 3)

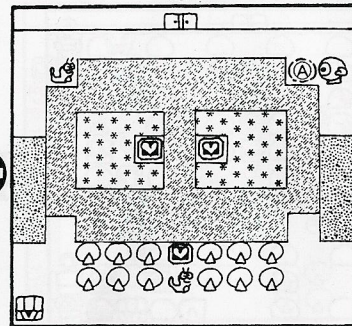
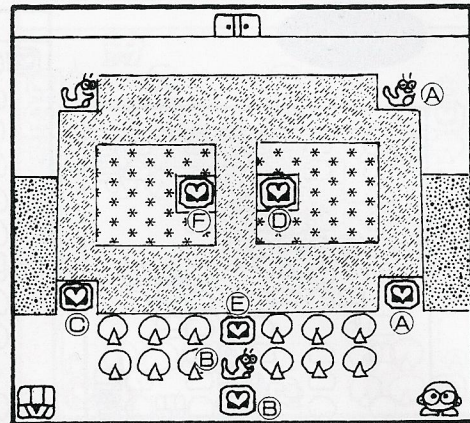

(Fig. 1)

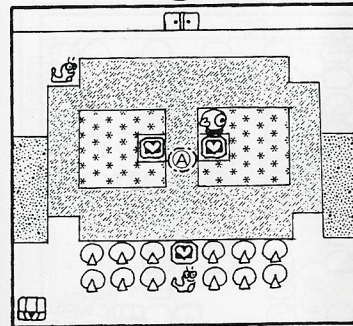

(Fig. 2)



1. Take HFs A, B and C. Use a MS to encase Snakey A. (Fig. 1)
2. Float the Egg on the water, and ride it over to the island. (Fig. 2)
3. Take HF D, and hop back on the Egg. When you reach the shore, take HF E. Use two MSs to get rid of Snakey B. (Fig. 3) Use the same method to pick up HF F. When Snakey B reappears, you can get rid of him again if necessary. For a challenge, try taking HFs D and F at the same time.

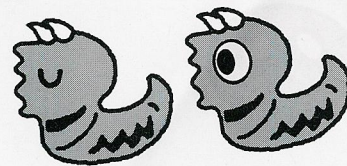

Floor 4-3

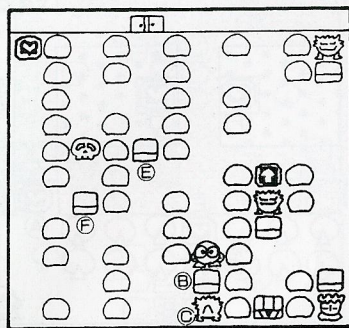

(Fig.3)

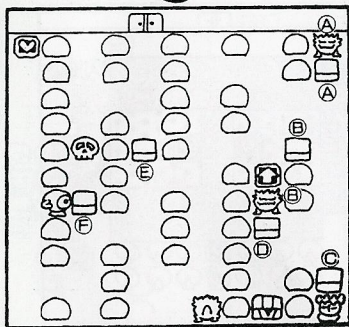
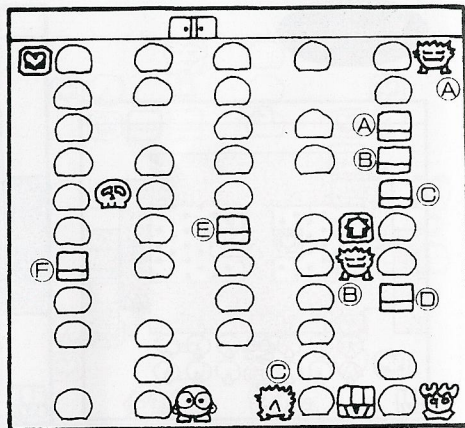

(Fig.2)

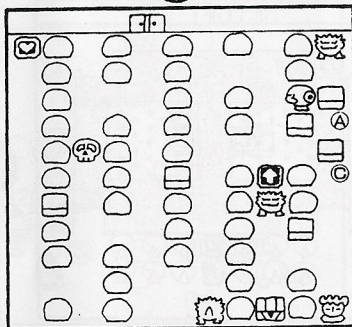

(Fig.1)

1. Go to the upper right and move EFs A and C to the right. (Fig. 1)
2. Move EF B down. Push EF A up to block Gol A, EF C down to block Medusa, and EF D to the left to block Gol B. Block Skull with EFs E and F as shown in the diagram. (Fig. 2)
3. Use EF B to block Gol C. (Fig. 3) Now take the HF, and the Jewel. But pick your exit route carefully!



Floor 4-4

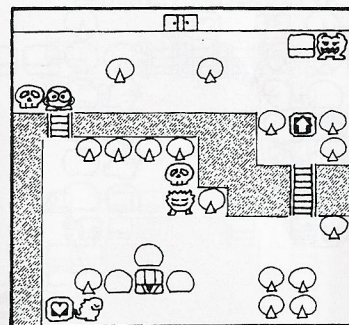

(Fig.3)

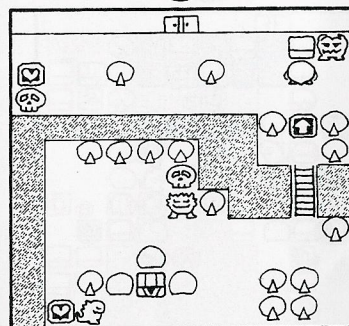
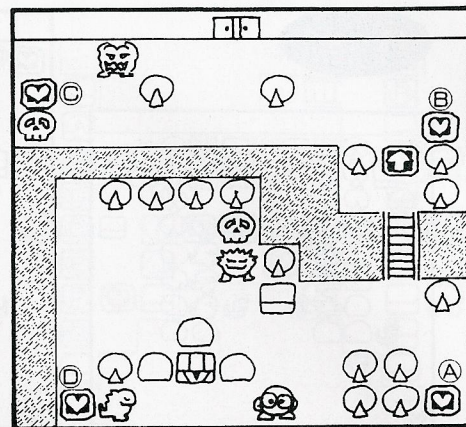

(Fig.2)

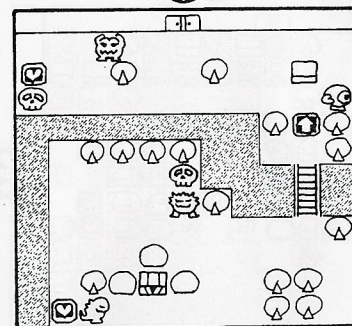

(Fig.1)

1. Being careful of Don Medusa, move the EF to the foot of the bridge. Take HF A, push the EF across the bridge, and take HF B. (Fig. 1)
2. Use the EF to trap Don Medusa against the right wall. (Fig. 2) Watch your timing!
3. Take HF C, then build a Bridge next to Skull. (Fig. 3) Cross the Bridge and take HF D. Use two MSs to get rid of Gol, and take the Jewel.

Floor 4-5

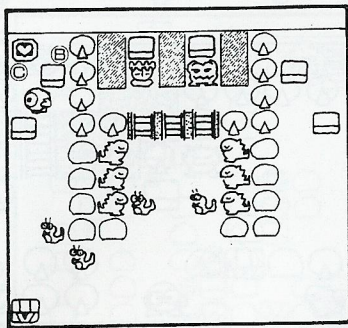

(Fig.3)

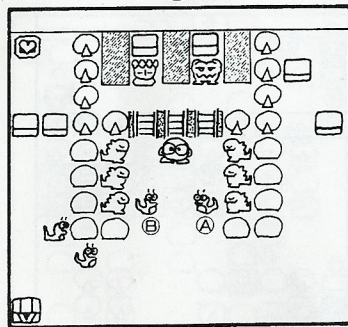
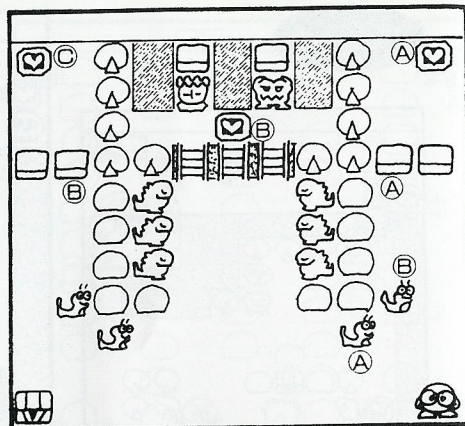

(Fig.2)

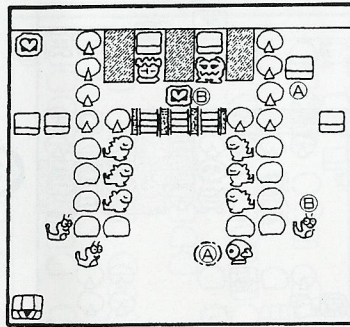

(Fig.1)

1. Use EF A to block Don Medusa on the right, and take HF A. Use a MS to encase Snakey A, and use the Egg to block Don Medusa on the bottom. (Fig. 1)
2. Take HF B, then encase Snakey B and use the Egg to block Medusa on the bottom. (Fig. 2)
3. Finally, move EF B two spaces up, and take HF C. (Fig. 3) Grab the Jewel, and you're off to the Fifth Floor.

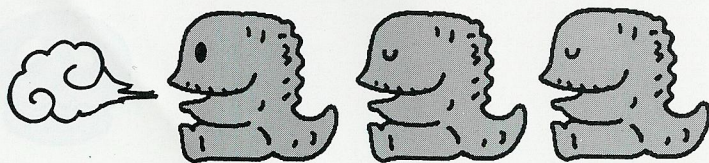

Floor 5-1

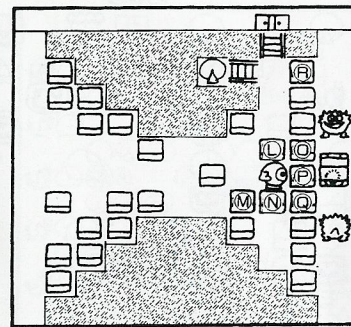

(Fig.3)

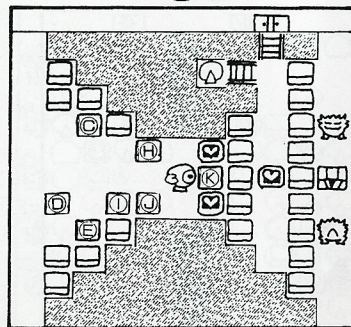
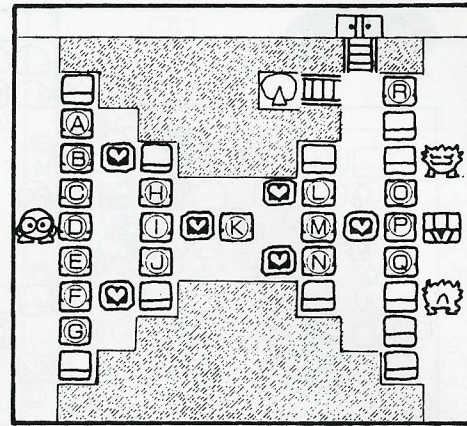

(Fig.2)

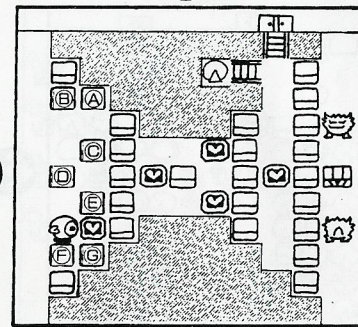

(Fig.1)

1. There are many ways to clear this room-we'll show you one. But be accurate when you move the EFs. A mistake in this kind of maze tends to compound itself. First move A and C to the right, B up, and take the HF. Then E and G to the right, F down, and the next HF. (Fig. 1)
2. Move C up, E down, and H and J each one space to the right. Now I down, and take the HF. Then K to the right. (Fig. 2)
3. Take the two HFs. Now move L and N to the right, M down and take the HF. (Fig. 3) Move O and Q to the right, P down, and take the Jewel. Once Gol disappears you can push O to the top, push R to the left, and out the door to the next room.

Floor 5-2

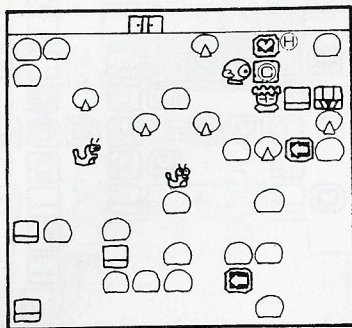

(Fig.3)

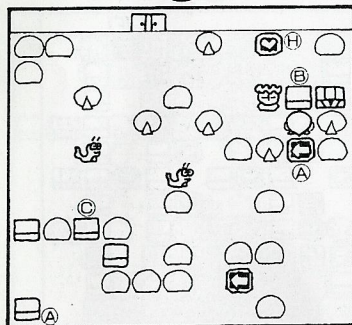
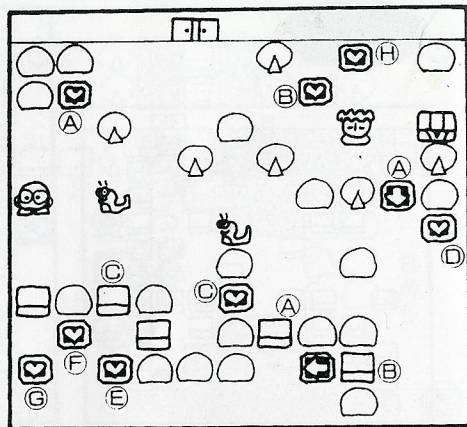

(Fig.2)

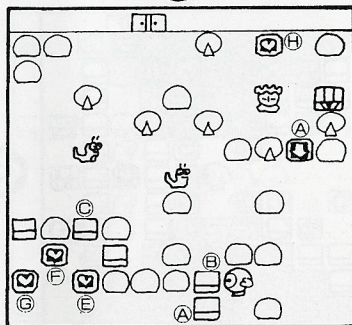

(Fig.1)

1. You can pick up HFs A, B, C and D, but be careful of Medusa. Push EF A all the way to the bottom. Push EF B through the One-Way Pass to the rock, stacking them up. (Fig. 1)
2. Pushing EF A, go to the left and pick up HFs E, F and G. Changing the direction of One-Way Pass A, push EF B up and block Medusa on the right. (Fig. 2)
3. Move EF C above Medusa, take HF H, and you're off to the next room!

Floor 5-3

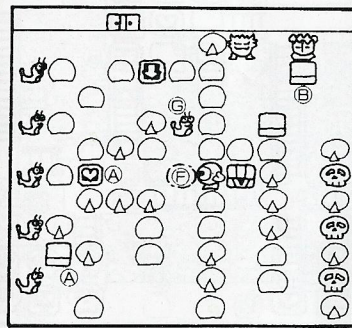

(Fig.3)

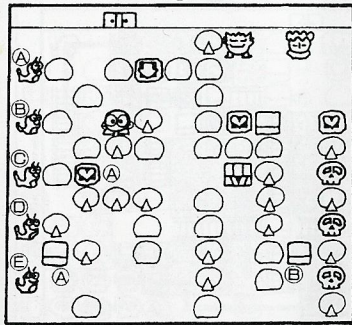
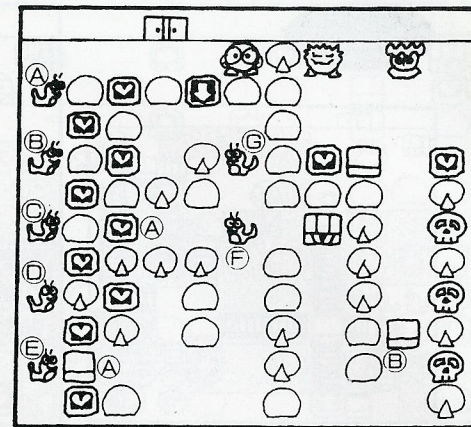

(Fig.2)

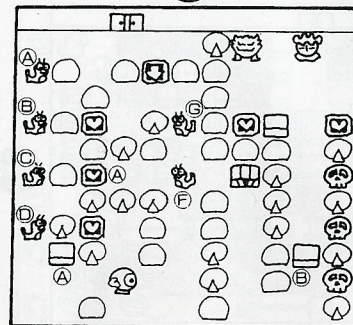

(Fig.1)

1. In this room, every time you take a HF you get two MSs. So you can go down the left side, picking up HFs and getting rid of Snakeys. (Fig. 1)
2. You can also get rid of Snakeys F and G this way, but be sure to leave HF A. (Fig. 1)
3. Push EF B up and block off Medusa, pick up the HFs, then go back to the Jewel Box. Remove Snakey F one more time. (Fig. 3) Take HF A, then race the Skulls to the Jewel Box!

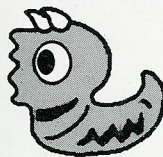

Floor 5-4

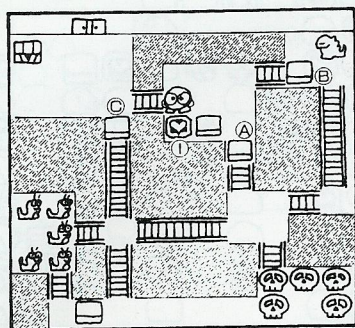

(Fig. 3)

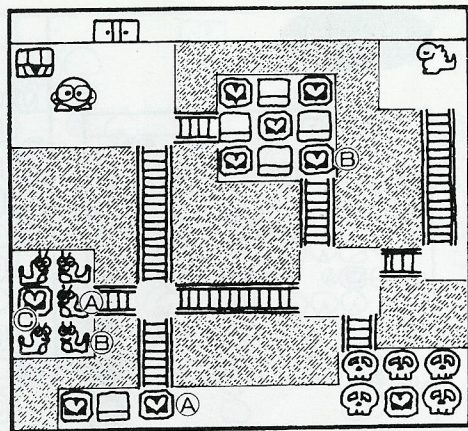

(Fig. 1)

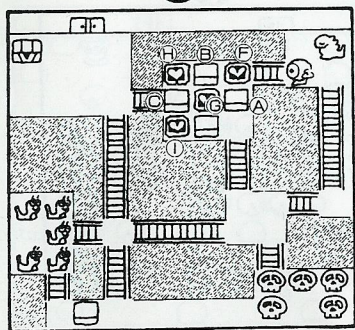

(Fig. 2)

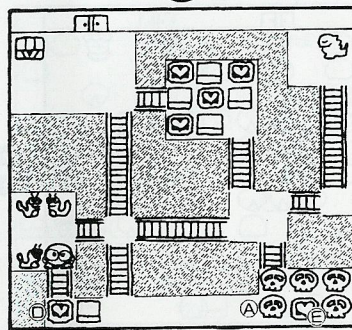

(Fig. 1)

1. First take HFs A and B. Bounce Snakey A out of the screen and take HF C. Do the same with Snakey B, then build a Bridge as shown in the diagram. (Fig. 1)
2. Take HF D, then re-cross the Bridge before the Snakeys reappear. Encase Skull A, take HF E, then build a Bridge as shown in the diagram. (Fig. 2)
3. Take HFs F, G and H, then use EFs A, B and C to trap the Skulls. (Fig. 3) Take HF I, then watch for Gol's flame when you go to the Jewel Box!

Floor 5-5

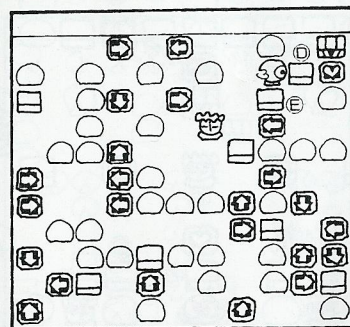

(Fig. 3)

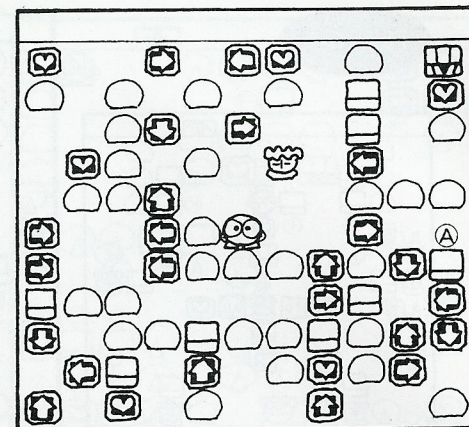

(Fig. 1)

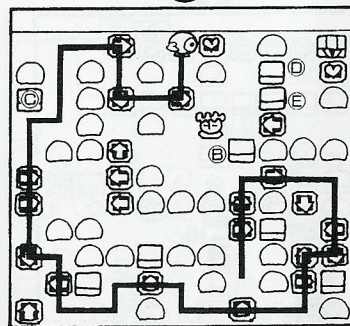

(Fig. 2)

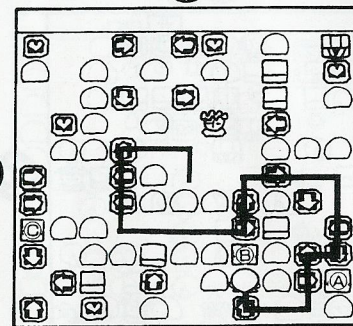

(Fig. 1)

1. Take the HFs as shown in the diagram. (Fig. 1) Push EF A all the way to the bottom.
2. Push EF B up to Medusa's right side, and EF C up against the rock. Then take the HFs as shown in the diagram. (Fig. 2)
3. Move EFD to the right. (Fig. 3) By moving EFE down and EFD up, you can take the last HF. Be careful of the many One-Way Passes in this room, and plan your moves well in advance. Now, on to Floor Six!

Floor 6-1

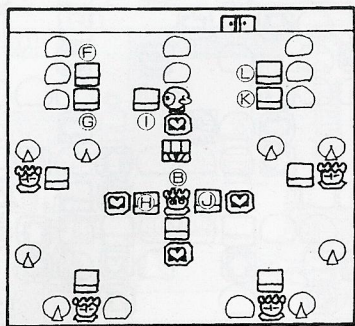

(Fig. 3)

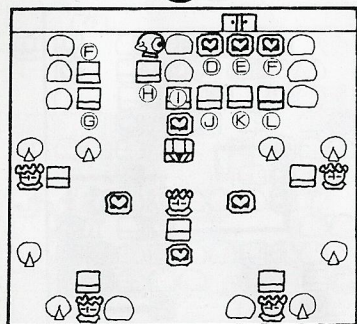

(Fig. 2)

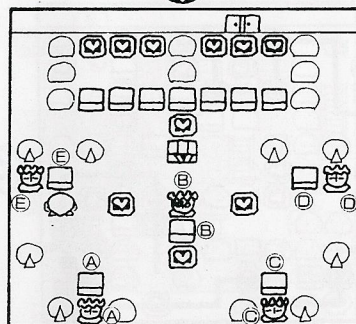

(Fig. 1)

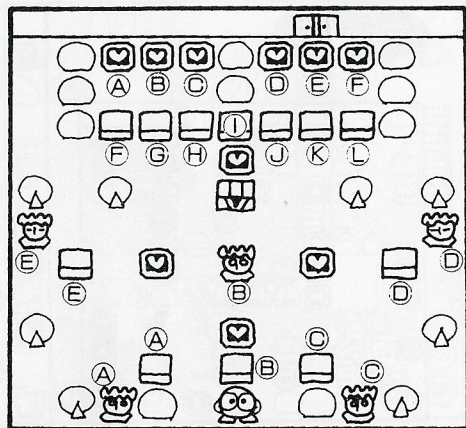

1. Move EFs A, B, C, D and E as shown to block off the Medusas. (Fig. 1)
2. Move EFs F and H up, G to the left, and take HFs A, B and C. (Fig. 2)
3. Move to the other side and use the same maneuver with EFs J, K and L, and HFs D, E and F. Block off Medusa B on the right and left with EFs H and J. Block off Medusa B from above with EF I. (Fig. 3) Now you can grab the Jewel, and clear the room.

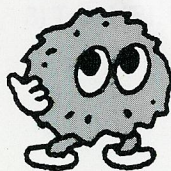

Floor 6-2

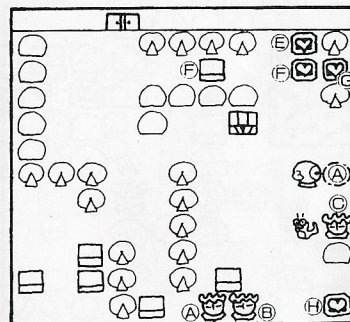

(Fig. 3)

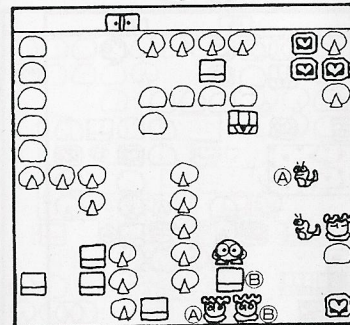

(Fig. 2)

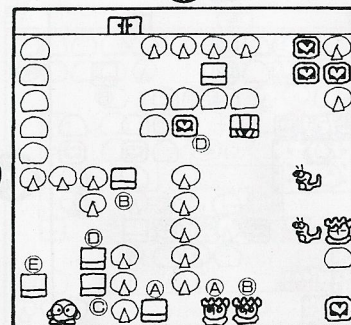

(Fig. 1)

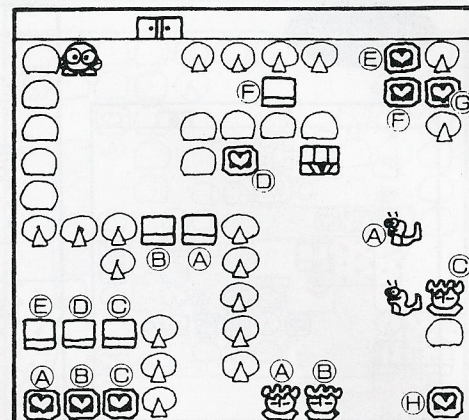

1. Use EF A to block off Medusa A on the left side. Move EFs C, D and E, and take HFs A, B and C. (Fig. 1)
2. Take HF D. Move EF B to a point between Medusas A and B, blocking them both off with one Framer. (Fig. 2)
3. Encase Snakey, and put the Egg above Medusa C. (Fig. 3) Take HFs E, F and G. Finally, move EF F down to the right of Medusa B, and take the last HF.

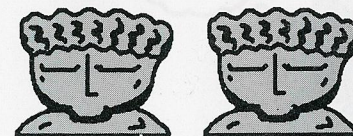

Floor 6-3

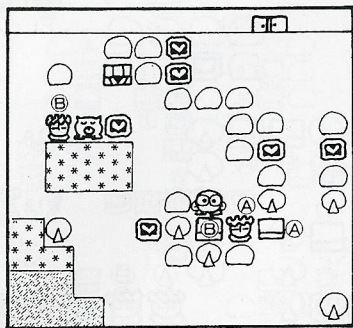

(Fig.3)

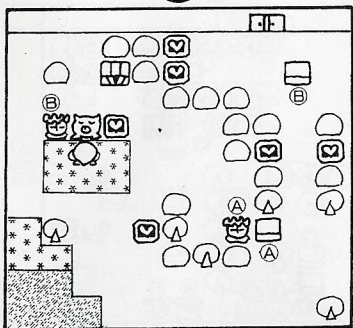
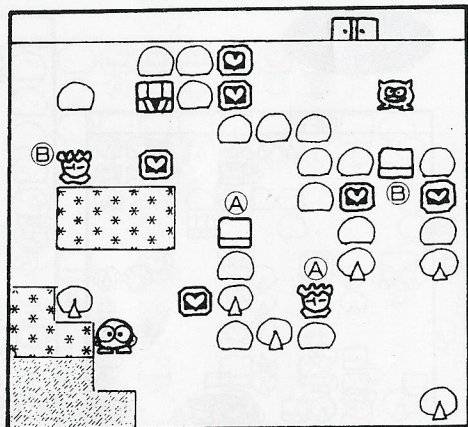

(Fig.2)

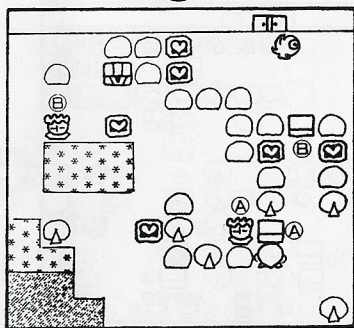

(Fig.1)

1. Use EF A to block Medusa A's right side. (Fig. 1)
2. Avoiding Leeper, move EF B exactly two spaces up. Go to the Flower Bed, and put Leeper to sleep in the spot shown in the diagram. (Fig. 2)
3. Move EF B again, this time to Medusa A's left side. (Fig. 3) Now you can take the HFs and clear the room.

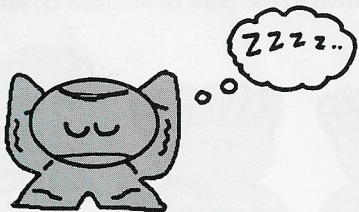

Floor 6-4

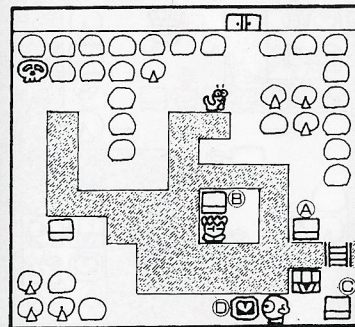

(Fig.3)

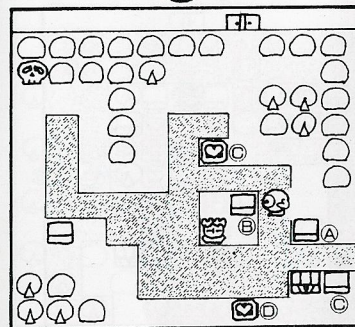
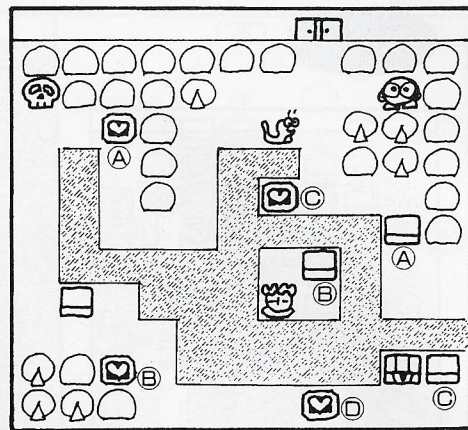

(Fig.2)

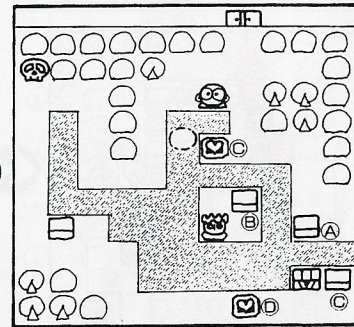

(Fig.1)

1. First take HFs A and B. Move EF A as shown, then encase Snakey and float the Egg in the water. (Fig. 1)
2. Move to EF A and cross over on the Egg to the island. (Fig. 2)
3. Push EF B in above Medusa, catch the Egg again, and take HF C. Build a Bridge in the corner, take HF D, (Fig. 3) and take the Jewel before Skull can capture you.

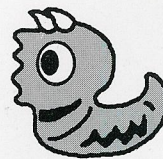

Floor 6-5

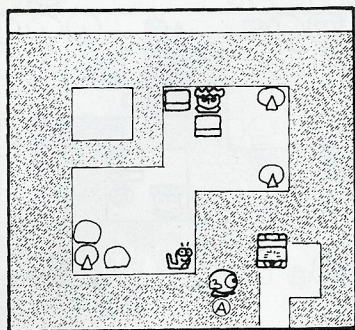

(Fig. 3)

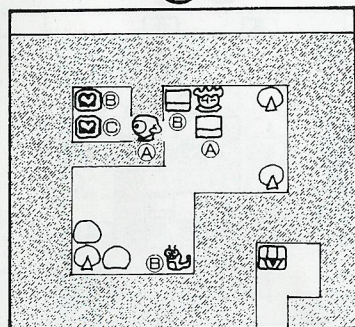

(Fig. 2)

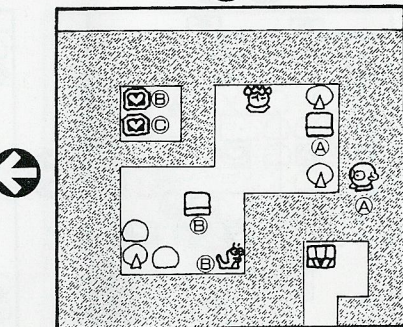

(Fig. 1)

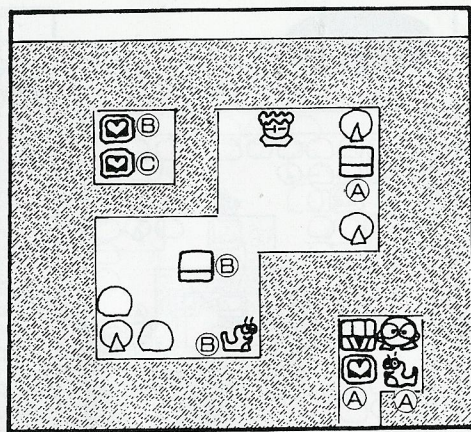

1. Take HF A. Encase Snakey, float the Egg on the water, and cross over to the island. (Fig. 1)
2. Block Medusa on the bottom with EF A, and his left side with EF B. Ride the Egg to the small island. (Fig. 2)
3. Take HFs B and C, and ride the Egg back to your original position. (Fig. 3) If you make a mistake, you still have one MS left.

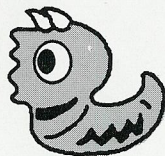

Floor 7-1

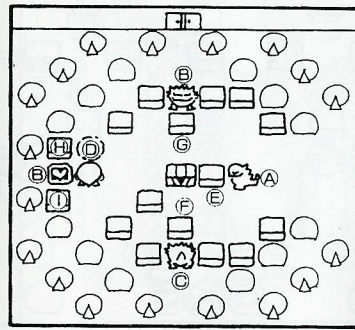

(Fig.3)

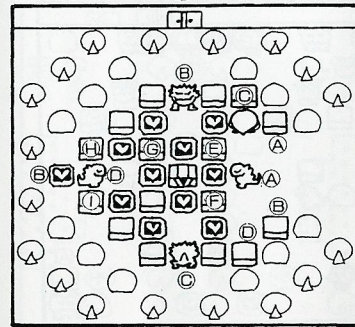

(Fig.2)

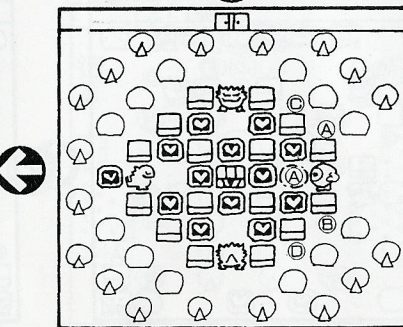

(Fig.1)

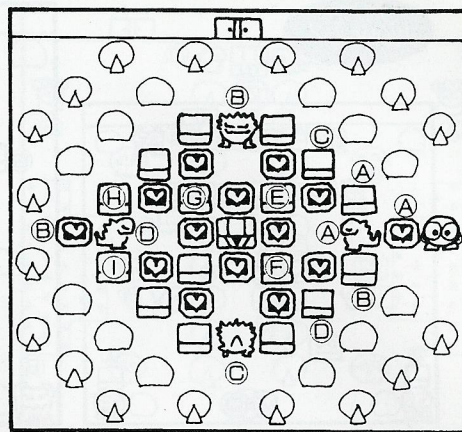

1. Don't let the complexity of this one throw you. First take HF A. Encase Gol A and move the Egg to the left. (Fig. 1)
2. Move EFs A and C up, B and D down, and take all the HFs except B. (Fig. 2)
3. Block Gols A, B and C with EFs E, F and G. Move EFs H and I to the left. Encase Gol D and move the Egg up. (Fig. 3) Take HF B, and the room is cleared.

Floor 7-2

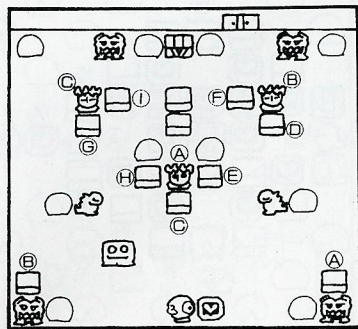

(Fig.3)

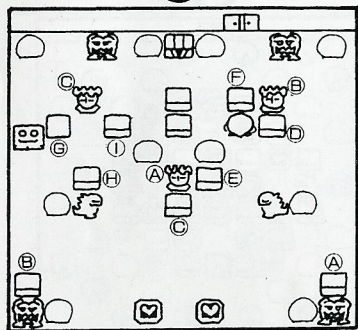
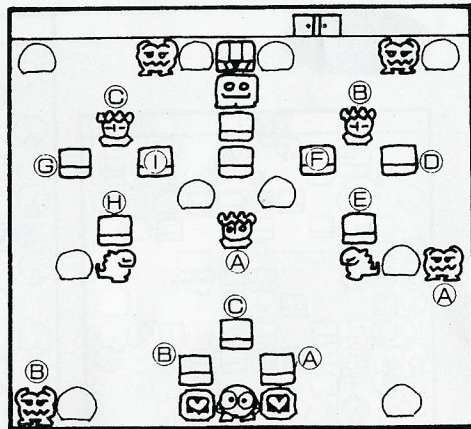

(Fig.2)

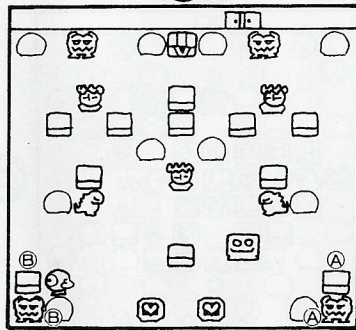

(Fig.1)

1. Block in Don Medusa A with EF A, and Don Medusa B with EF B. (Fig. 1)
2. Push EF C up against Medusa A. Block Medusa B on the bottom and left with EFs D and F, and Medusa A's right side with EF E. (Fig. 2)
3. Block Medusa C with EFs G and I, and Medusa A's left side with EF H. (Fig. 3) Take the last HF. Watch your route, and take the Jewel.

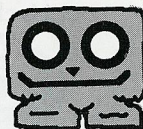
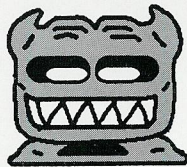
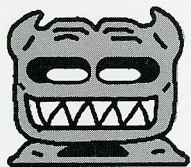

Floor 7-3

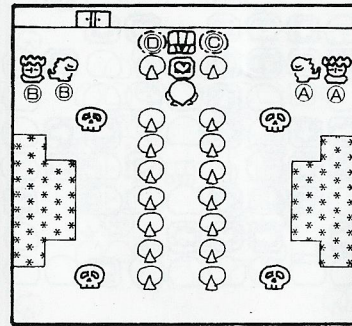

(Fig.3)

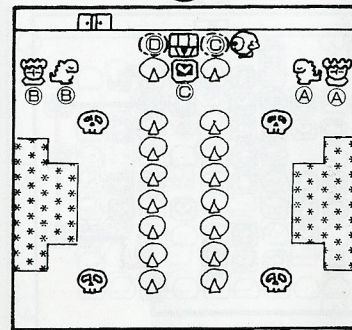
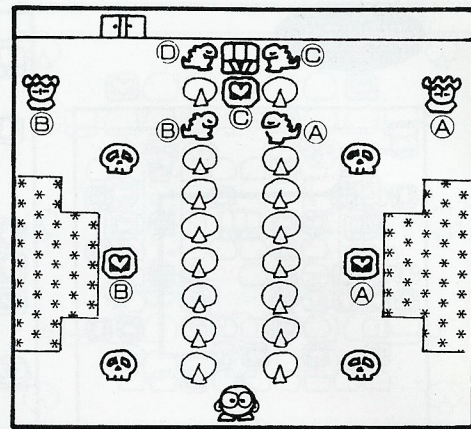

(Fig.2)

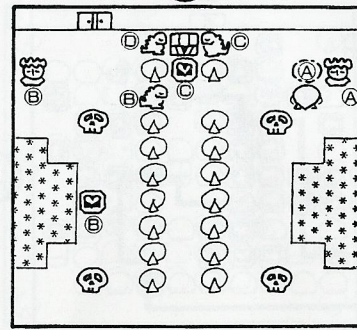

(Fig.1)

1. First take HF A. Encase Gol A and use the Egg to block Medusa A's left side. (Fig. 1)
2. Do the same with Gol B, and block Medusa B. Take HF B. Now you'll have to work fast. Encase Gols C and D. (Fig. 2)
3. Quickly take HF C, and the Jewel. (Fig. 3)

Floor 8-1

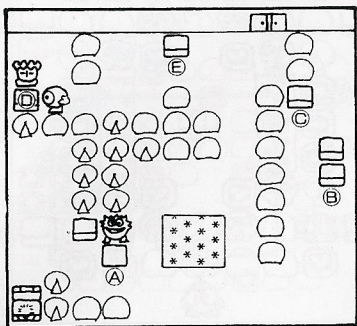

(Fig. 3)

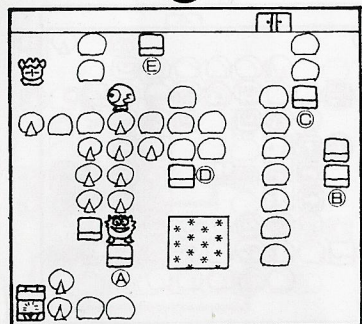
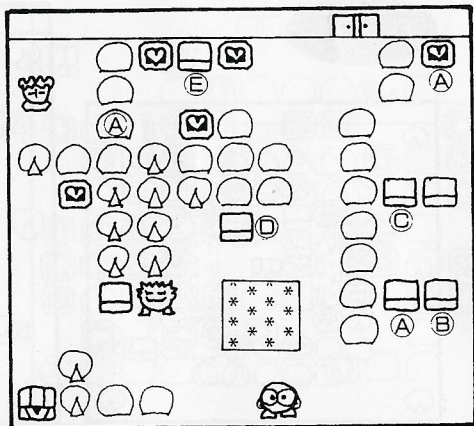

(Fig. 2)

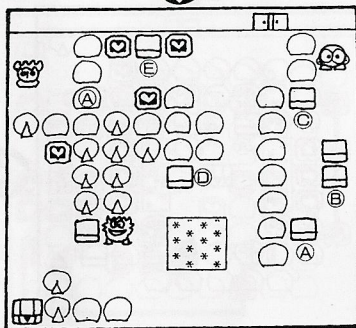

(Fig. 1)

1. Moving EFs B and C up, take HF A. (Fig. 1)
2. Use EF A to Block off Gol, then take all the HFs. Use your Hammer to smash Rock A. (Fig. 2)
3. Move EF E exactly one space to the right. Now block Medusa with EF D, and you'll be able to clear the room. (Fig. 3)

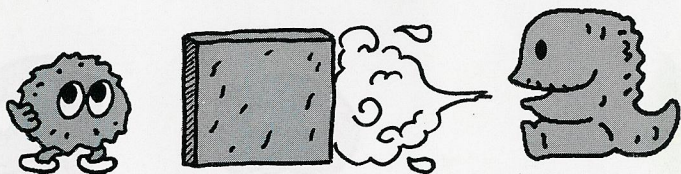

Floor 8-2

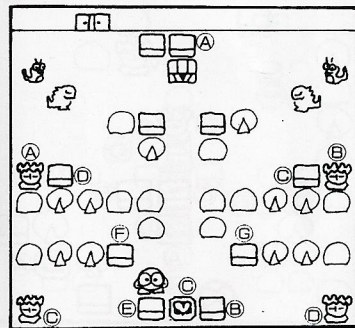

(Fig. 3)

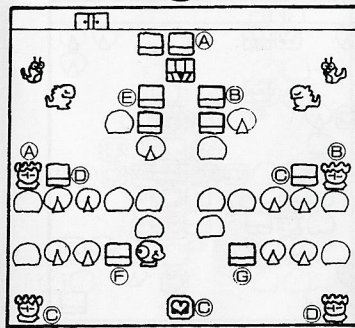
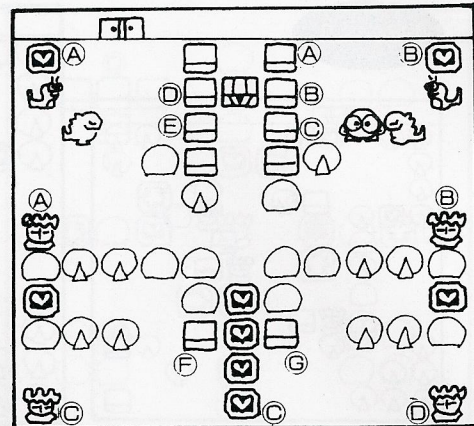

(Fig. 2)

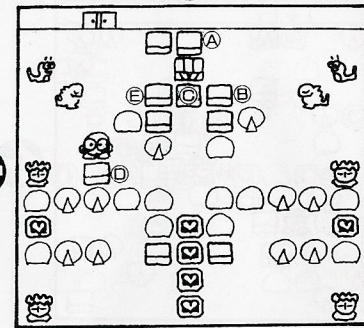

(Fig. 1)

1. First take HF B. Move EFs A and C to the left, and EF B down. Move EF D as shown in the diagram. (Fig. 1)
2. Use EFs C and D to block Medusas A and B. Take all the HFs except C. Move EFs F and G as shown in the diagram. (Fig. 2)
3. Block off Medusas C and D with EFs B and E. (Fig. 3) Now take HF C and clear the room.

Floor 8-3

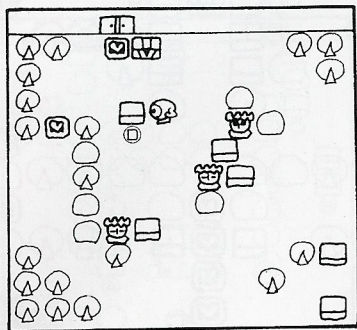

(Fig. 3)

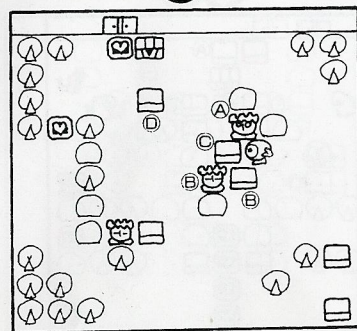
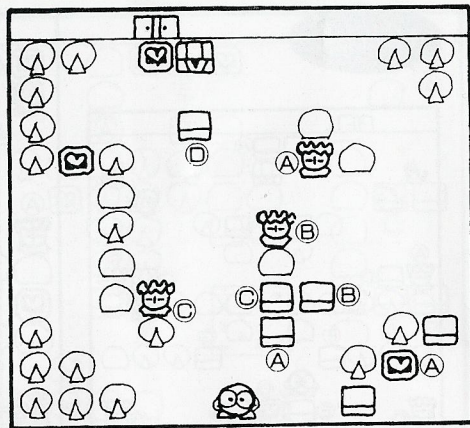

(Fig. 2)

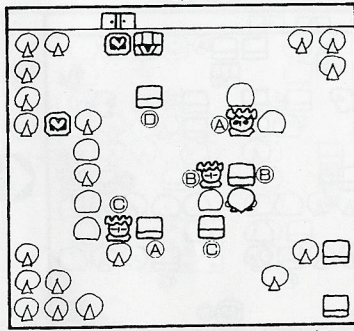

(Fig. 1)

1. First take HF A, then block off Medusa C with EF A, and Medusa B with EF B. (Fig. 1)
2. Block off Medusas A and B with EF C as shown. (Fig. 2)
3. Move EF D down half a space and to the left half a space. (Fig. 3) Now you can take the last HF.

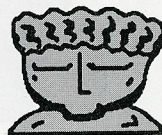

Floor 8-4

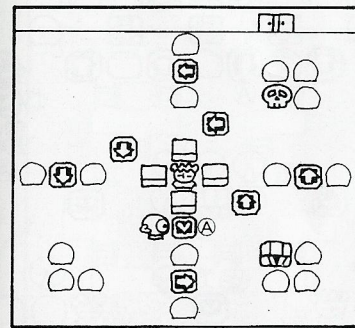

(Fig. 3)

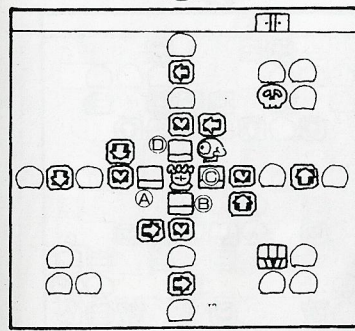
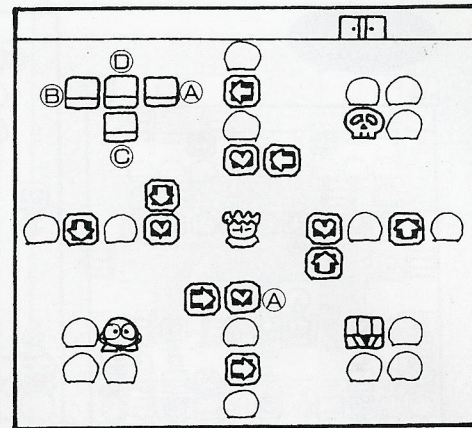

(Fig. 2)

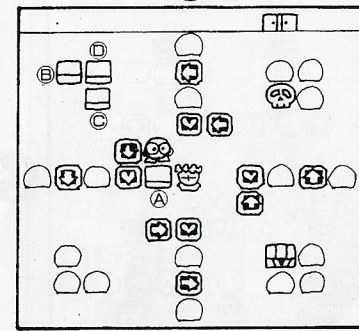

(Fig. 1)

1. First block off Medusa's left side with EF A (Fig. 1)
2. Using the One-Way Passes, move EFs B, C and D to block Medusa on all sides. (Fig. 2)
3. Now take the HFs. When you take the last one, Skull will start to chase you, so you might want to take HF A last.

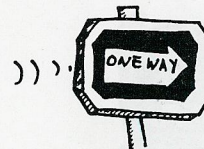

Floor 8-5

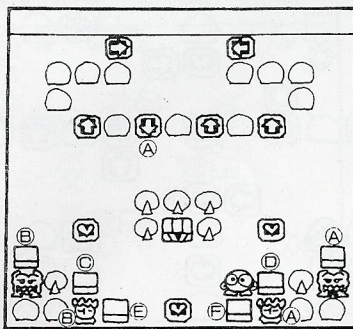

(Fig.1)

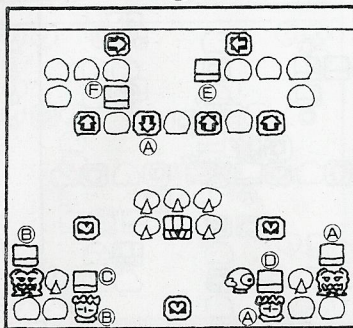

(Fig.2)

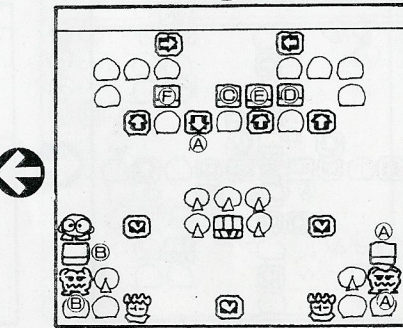

(Fig.3)

1. Take HFs A and B, then move EF A down and, watching your timing, trap Don Medusa A in the bottom right. Move EF E down one space, and use EF B in the same way to trap Don Medusa B. (Fig. 1)
2. Move EF E back up one space, and bring EFs C and D down to block Medusas A and B on the top. (Fig. 2)
3. Bring EFs E and F down and place them as shown. (Fig. 3) Now you can take the rest of the HFs.

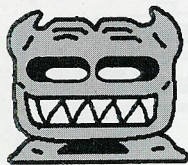

Floor 9-1

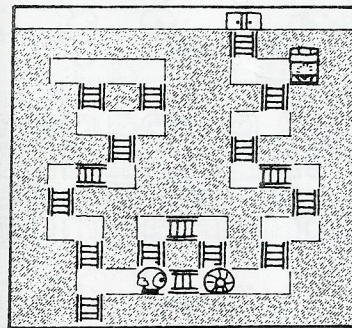

(Fig.1)

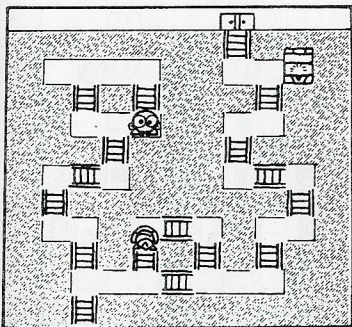

(Fig.2)

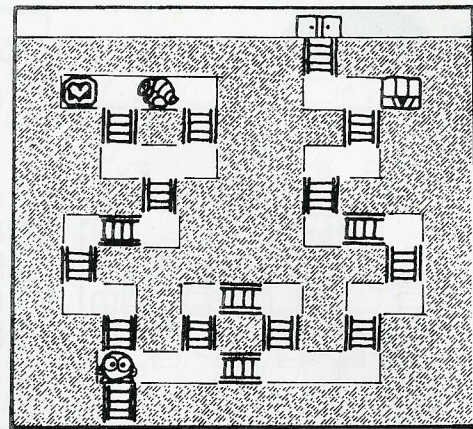

(Fig.3)

1. Move immediately to the spot shown and wait for Alma. (Fig. 1)
2. When Alma approaches, quickly circle counter-clockwise and, using the bridges to the upper left, take the HF. (Fig. 2)
3. Now Alma will reverse direction. Go to the spot shown and wait again. (Fig. 3) When Alma comes again, circle quickly clock-wise, and the path will be clear to the Jewel Box.

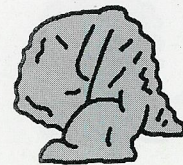
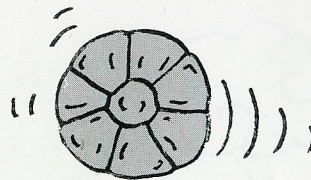

Floor 9-2

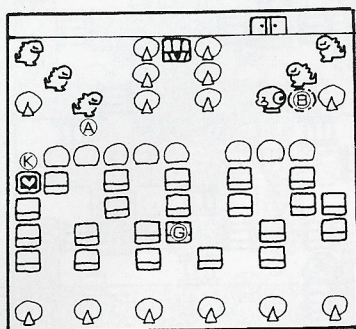

(Fig.3)

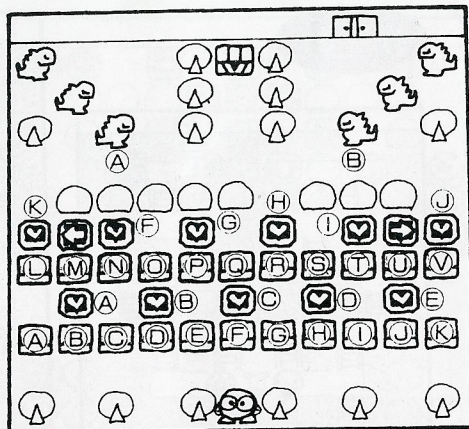

(Fig.1)

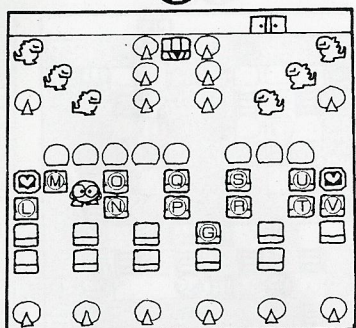

(Fig.2)

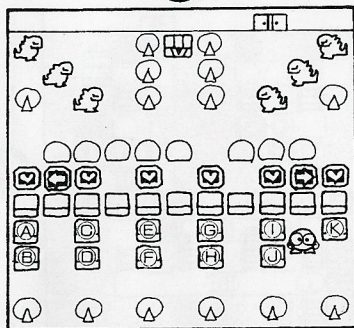

1. Moving the EFs one by one to the position shown, take HFs A, B, C, D and E. (Fig. 1)
2. Moving the EFs once more, take HFs F, G, H and I. (Fig. 2)
3. Moving EF G to the left to make a path, take HF J. Encase Gols A and B and move them to the sides. (Fig. 3) Now you can take HF K and the Jewel.

Floor 9-3

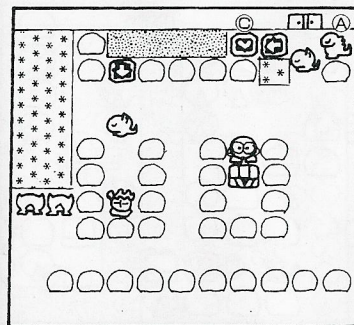

(Fig.3)

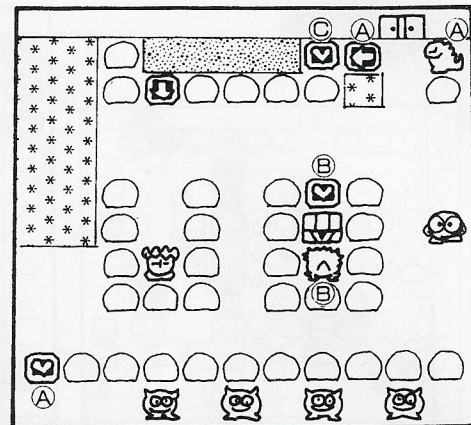

(Fig.1)

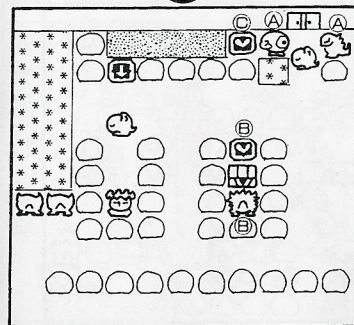

(Fig.2)

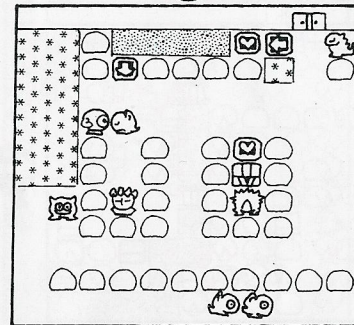

1. Take HF A and let the Leepers out. Using the Flower Bed to time your move, put Leeper A to sleep in the point shown. (Fig. 1)
2. Now put two Leepers to sleep at the bottom of the Flower Bed, and the fourth at the One-Way Pass as shown. (Fig. 3)
3. Take HF B, then use your two MSs to get rid of Gol B. (Fig. 3) Take HF C, then rush to the Jewel Box before Gol B reappears.

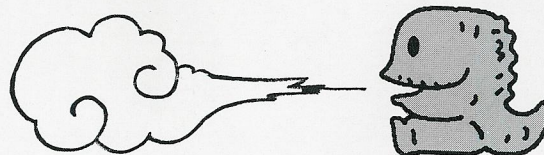

INTERMISSION

All right, you've made it to the last floor! If you manage to clear this floor, you'll be able to rescue Princess Lala. But this floor is made up of five particularly difficult rooms. You'll need all your experience and know-how to clear this floor!

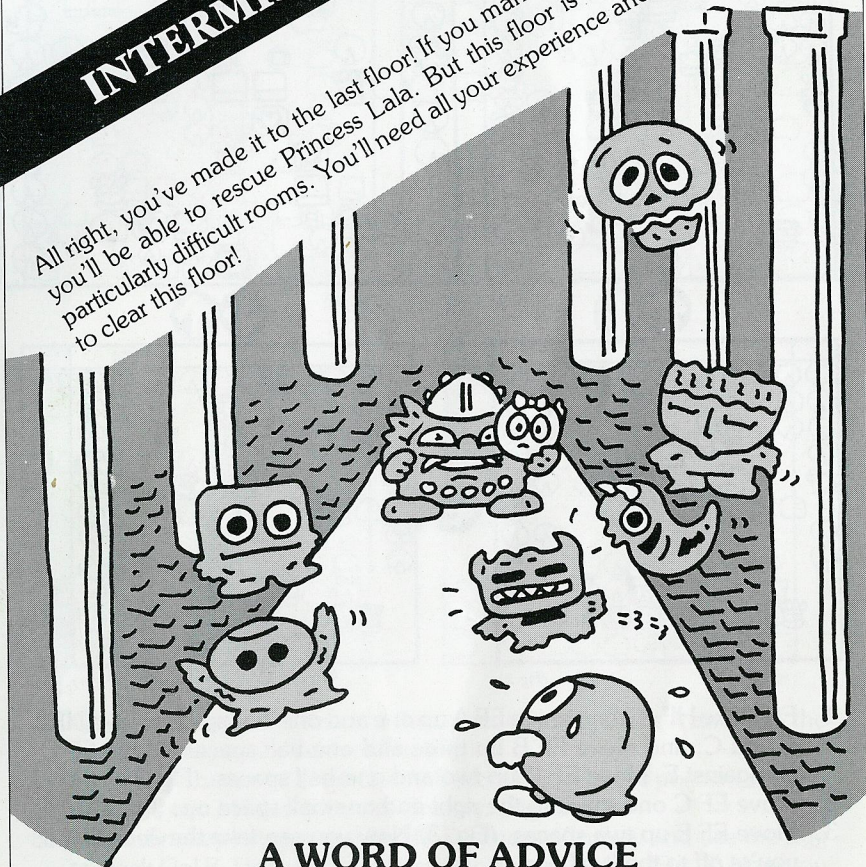

A WORD OF ADVICE

It's very important to work as quickly as possible in the last room. If you hesitate you'll run out of Magic Shots and will be easily defeated by the long rows of Gols guarding the Jewel. You'll probably have to challenge this one many times before you discover the secret to clearing the room.

Floor 10-1

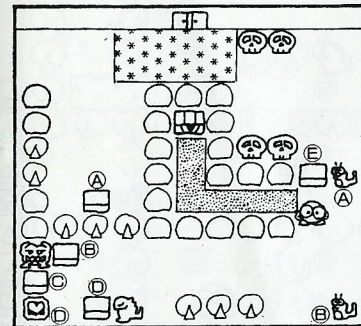

(Fig. 3)

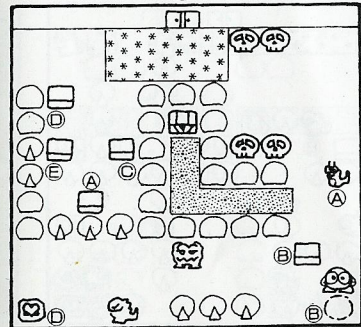
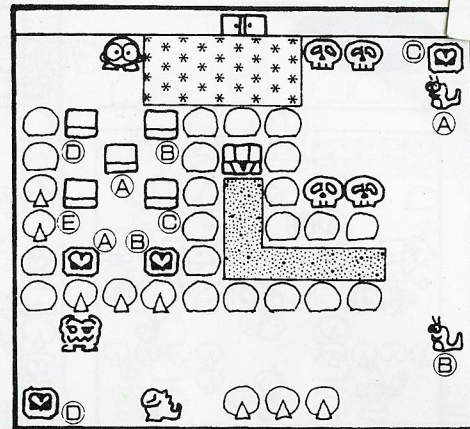

(Fig. 2)

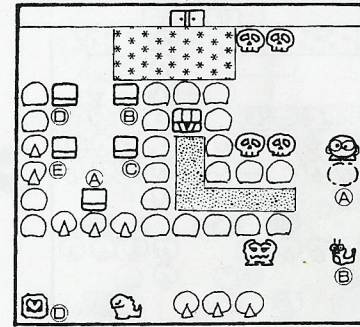

(Fig. 1)

1. Move EF A down and, avoiding Don Medusa's line of sight, take HF5 A and B. Take HF C, encase Snakey A, and move the Egg to the point shown. (Fig. 1)
2. Bring EF B to the position shown, then encase Snakey B and move him down. (Fig. 2)
3. Push Don Medusa all the way to the left. Use EFs C and D to block Don Medusa and Gol. Move EF E to Snakey A's left side. (Fig. 3) Finally, take HF D and the Jewel is yours.

Floor 10-2

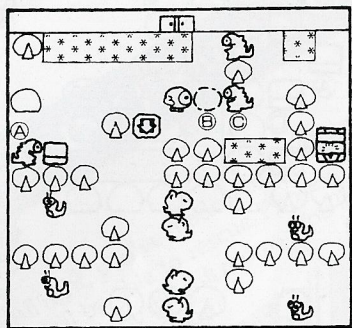

(Fig. 3)

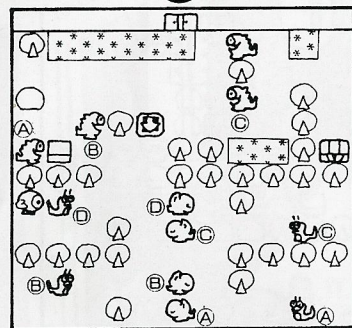

(Fig. 2)

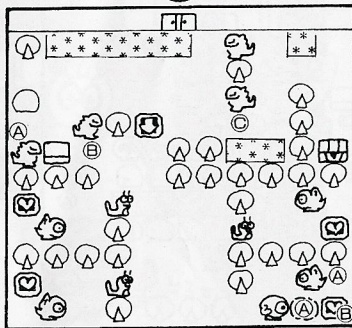

(Fig. 1)

1. Moving the EF down, take HF A. Encase Snakey A, quickly push him in as shown, then immediately run as far left as possible. (Fig. 1)
2. This will put Leeper to sleep in the position shown. (Fig. 2) Take each HF in this way.
3. Now encase Gol B and use the Egg to block Gol C. (Fig. 3) Now you can clear the room.

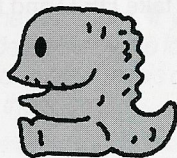
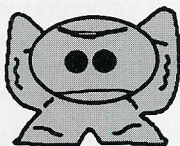

Floor 10-3

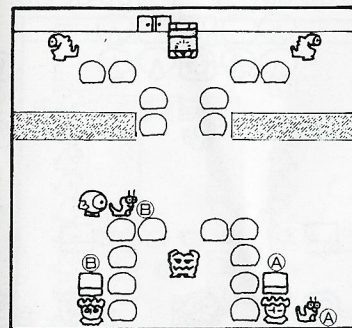

(Fig. 3)

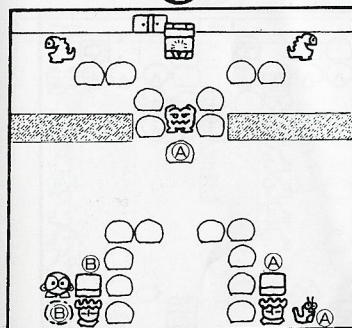

(Fig. 2)

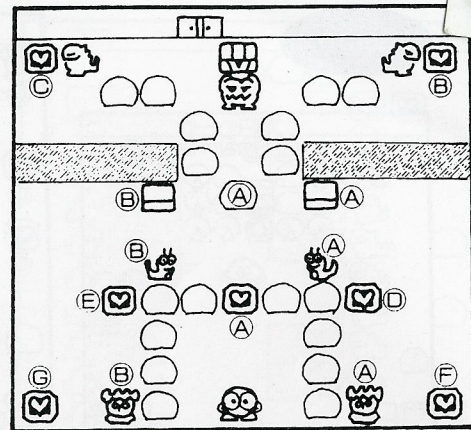

(Fig. 1)



1. Take HF A, then encase Snakey A. Push the Egg all the way to the right and up, and float it in the water. Cross the stream and take HF B. Cross again, moving EF A down exactly one space. Then perform the same maneuver on the other side. (Fig. 1)
2. Block Medusas A and B with EFs A and B. Use the Snakeys once again to block the Medusas on the sides, and take HFs F and G. Use one more MS to get rid of Snakey B. (Fig. 2)
3. Now timing is crucial. Shatter Rock A, then run to the side of Snakey B. When Don Medusa comes out, encase Snakey and use the Egg to block him in among the bottom rocks. (Fig. 3) Now you can take the Jewel.

Floor 10-4

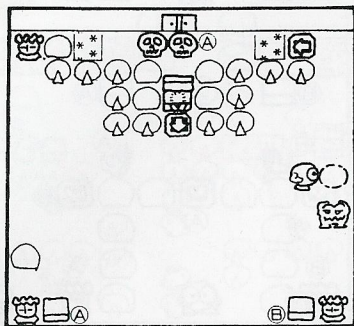

(Fig. 3)

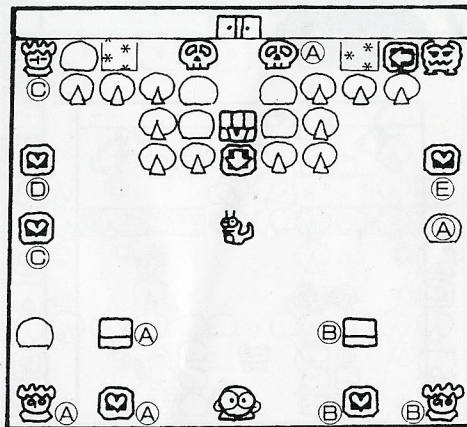

(Fig. 1)

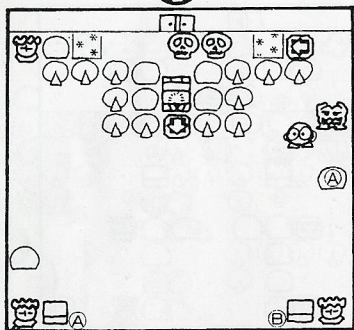

(Fig. 2)

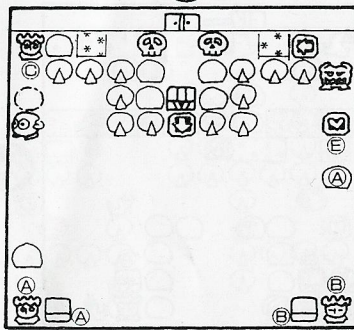

(Fig. 1)

1. Use EFs A and B to block in Medusas A and B, and take HFs A, B and C. Encase Snakey, and push the Egg in under Medusa C. Take HF D, then quickly shoot the Egg from the screen. (Fig. 1)
2. When Snakey reappears, encase him again, push the Egg to the right to block off Don Medusa, and take HF E. Immediately use another shot to get rid of the Egg, and run to Rock A. (Fig. 2)
3. On Don Medusa's upswing, smash the rock and run immediately to the side of EF B. When Snakey reappears, encase him again and use the Egg to block Don Medusa in the lower right corner. (Fig. 3) Finally, encase Skull A, push the Egg aside, and take the Jewel.

Floor 10-5

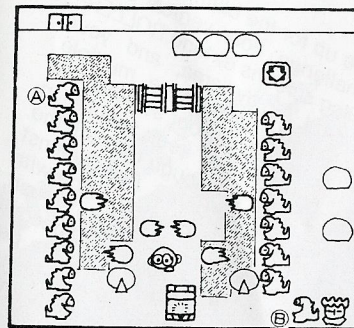

(Fig. 3)

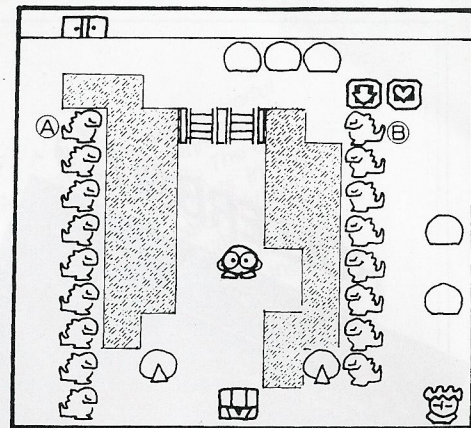

(Fig. 1)

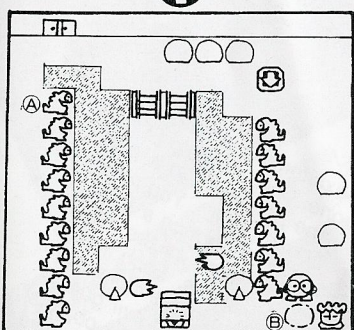

(Fig. 2)

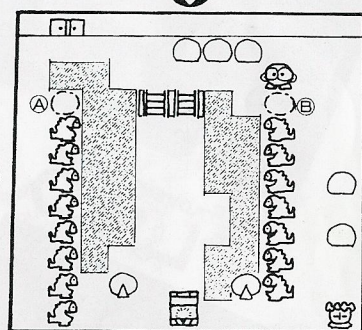

(Fig. 1)

1. At last, the final challenge! If you clear this room you meet the Great Devil himself! First, take the HF. Use a MS to encase Gol A, quickly move to the other side, and encase Gol B. (Fig. 1)
2. Move the Egg to the bottom of the screen and block off Medusa. (Fig. 2)
3. Now, if you start from a point directly between the staircases, you can outrun the flames. Don't miss the little jog to the right at the end. Now, the Great Devil himself!

ROLLERBALL™



Fire up for the ultimate pinball challenge. Four vertical scrolling screens extend ROLLERBALL's play area, and your balls on all four screens, multiple hot! Can you keep your ball in play long enough to reach the highest score? Play against the game, or one on one with friends on the second screen, hockey version. You'll become a pinball wizard! It's the perfect family game (parents will love it because there's lots of fun, but no violence).

ADVENTURES OF LOLO™



The excitement sizzles with this one. Can you help LOLO save the princess LALA from the Great Devil? You must guide LOLO through a series of 50 different mazes filled with evil spirits. Each maze offers an ingenious triple challenge: dodge the evil guardians, move the maze objects in correct sequence, and solve the lethal puzzle by collecting the power objects. A game the whole family can enjoy, LOLO, from HAL America, is designed to improve your thinking skills.

HAL™
HAL AMERICA INC.
The Pinatic Specialists

7873 S.W. Cirrus Drive Building 25F
Beaverton, Oregon 97005
Tel. 503/644-4117 Fax. 503/641-5119
© HAL LABORATORY, INC 1988
TM and © HAL America, INC 1989
All Rights Reserved
Made in Japan

AIR FORTRESS™



A mysterious and powerful AIR FORTRESS is threatening the planet FARMEL. The destiny of FARMEL rests in the abilities of one specially trained person code number 82592 - HAL BAILMAN. His mission: Save FARMEL from the AIR FORTRESS.

VEGAS DREAM™

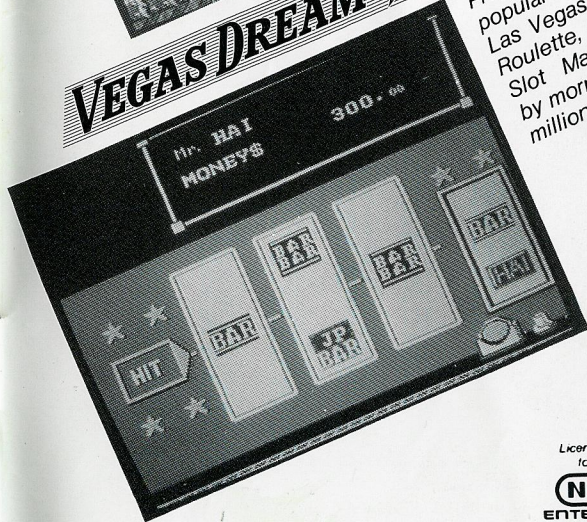

Prepare for a night out at the popular casino on the strip in Las Vegas. Test your skill on Roulette, Blackjack, Keno, or Slot Machines. Who knows, by morning, you could be a millionaire.

Licensed by Nintendo
for play on the
Nintendo
ENTERTAINMENT
SYSTEM™



