

CRASH

ZX SPECTRUM

A NEWSFIELD PUBLICATION
No.35 DECEMBER 1986

£1

164 ACTION-PACKED PAGES!

COBRA

YOU ARE
THE CURE

THE GREAT ESCAPE

Ocean's mega smash

HANNAH'S GREAT TIPS

GLIDER RIDER and
LIGHTFORCE mapped

DESIGNER PROGRAMMING
DAN MALONE tells all

A PROFUSION OF PREVIEWS

We look at a host
of unfinished games

SPECTRUM
MONTHLY SPECTRUM SOFTWARE REVIEW
WIN! WIN! WIN!
A COMPACT DISK and
copies of ACADEMY,
tour of London
with CITY
SLICKER

**GUARANTEED
100% PURE**

No film stills, or screen shots
from other computers



Crime is a disease. He's the cure.



STALLONE
COBRA



ocean

SPECTRUM

£7.95

COMMODORE 64

£8.95

AMSTRAD

© 1986 Warner Bros. Inc.
All rights reserved.

6 Central Street • Manchester M2 5NS
Tel: 061 834 3939 • Telex: 669977



CRASH

ZX SPECTRUM

ISSUE NO. 35 December 1986

PUBLISHERS

Roger Kean, Oliver Frey, Franco Frey
Publishing Executive/Editor

Graeme Kidd

Assistant Editor

Lee Paddon

Staff Writers

Lloyd Mangram, Hannah Smith

Adventure Editor

Derek Brewster

Strategy Editor

Sean Masterson

Tech Tipster

Simon Goodwin

Contributing Writers

Jon Bates, Brendon Kavanagh,

Rosetta McLeod, John Minson, Bill

Scolding

Production Controller

David Western

Art Director

Dick Shiner

Illustrators

Ian Craig, Oliver Frey

Production

Seb Clare, Tim Croton, Gordon Druce,

Mark Kendrick, Tony Lorton, Michael

Parkinson, Cameron Pound, Jonathan

Rignall, Matthew Uffindell

Advertisement Manager

Roger Bennett

Advertisement Assistant

Nick Wild

Subscriptions

Denise Roberts

Mail Order

Carol Kinsey

Editorial and Production

1/2 King Street, Ludlow, Shrop-

shire, SY8 1AQ

☎0584 5851

Mail Order and Subscriptions

PO Box 10, Ludlow, Shropshire, SY8

1DB

☎0584 5620

ADVERTISING

Bookings

☎0584 4603 OR 0584 5852

Printed in England by Carlisle Web

Offset Ltd, Newtown Trading Estate,

Carlisle, Cumbria, CA2 7NR —

member of the BPCC Group

Distributed by COMAG, Tavistock

Road, West Drayton, Middlesex, UB7

7QE

No material may be reproduced in whole or part

without the written consent of the copyright holders.

We cannot undertake to return any written

or photographic material sent in to CRASH

Magazine unless accompanied by a suitably

stamped, addressed envelope. Unsolicited written

or photo material which may be used in the

magazine is paid for at our current rates.

©1986 Newsfield Ltd

NP

A NEWSFIELD PUBLICATION

ABC

MEMBER OF THE ABC/1
BUREAU OF CIRCULATIONS

CRASH ABC FIGURE:

101,483 Total

97,992 UK and EIRE

Cover by Oliver Frey

REGULARS

7 EDITORIAL

12 NEWS

14 FEAR AND LOATHING

Hunter S goes bald!

42 LLOYD MANGRAM'S FORUM

The pre-Christmas rush to write to Lloyd is on. Gareth Jones sent us the first Xmas card of '86, though...

58 CRASH COURSE

Rosetta gets to grips with a bit more screen learnin'

67 DEREK BREWSTER'S ADVENTURE TRAIL

Derek takes a peek at adventure fanzines and SMASHes a game...

74 SIGNSTUMPS

The adventurer's forum goes from strength to strength

79 HANNAH SMITH'S PLAYING TIPS

Hannah wades in with a GLIDER RIDER map and a veritable heap of handy hints to make gameplaying that bit easier

90 THE CRASH HOTLINE AND ADVENTURE CHARTS

92 LLOYD MANGRAM'S HALL OF SLIME
It gets cold on the Ludlow gibbet this time of year...

99 RESULTS

Prizes galore. We'll have to book extra pages for the Christmas Special competition results, just you see!

105 TECH NICHE

Dominic Handy gets to grips with a ROM-based wordprocessor from RAM ELECTRONICS while Jon Bates investigates another MIDI interface

109 TECH TIPS

The irrepressible Simon Goodwin presents another collection of TechnoTips

120 PBM MAILBOX

Brendon goes football crazy and gets tipping!

126 SEAN MASTERSON'S FRONTLINE

And it's Goodbye From Him. Sean moves on to pastures new, but reviews a couple of games by way of a goodbye

157 MERELY MANGRAM

Once again, the workload on his new magazine keeps Lloyd away from the preview pages. Lotsa news though...

FEATURES

60 GENESIS BIRTH OF A GAME

The gestation period takes a little longer than expected...

62 DESIGNING GAMES THE MALONE WAY

Lee Paddon discusses game designing with PALACE's artist, DAN MALONE

114 ANALYSING THE ADVERTISING

Bill Scolding casts a critical eye over the Software Advertising Industry and its output

DIY

54 SHAO LIN TWO

The Competition Minion has been castigated and we re-run THE EDGE's comp that appeared last month without any differences. Sorry!

65 WIN A COMPACT DISC PLAYER

CRL offer a high-tech toy at top prize in their ACADEMY competition. Fifty games go to runners up

75 WIN A SIGNED FOOTBALL

A ball signed by the England Squad is waiting to be won, as well as fifty copies of BUG BYTE's latest Football game, PETER SHILTON's HANDBALL MARADONNA

89 GO ON A TRIP TO LONDON

Hewson's offer a sightseeing trip to the Smoke, all expenses paid in honour of CITY SLICKER. Fifty games go to runners up, too

97 BECOME A SUPERHERO!

Binoculars and a 35mm compact camera form the top prize in the COSMIC SHOCK ABSORBER Competition. The usual fifty games up for grabs, naturally

The annual CRASH Christmas Extravaganza is on its way — look in the Newsagent's on 10th December

A Hurricane of Software

Feel yourself uncontrollably drawn into a maelstrom of panic, a frenzy of action as you face the challenge of this outstanding collection of titles assembled for your Spectrum.

Precision and skill, speed and reflexes, alertness and ingenuity are all to be found in the fury of latest releases. However good you are you'll find it difficult to keep your head above water against this hurricane of software.

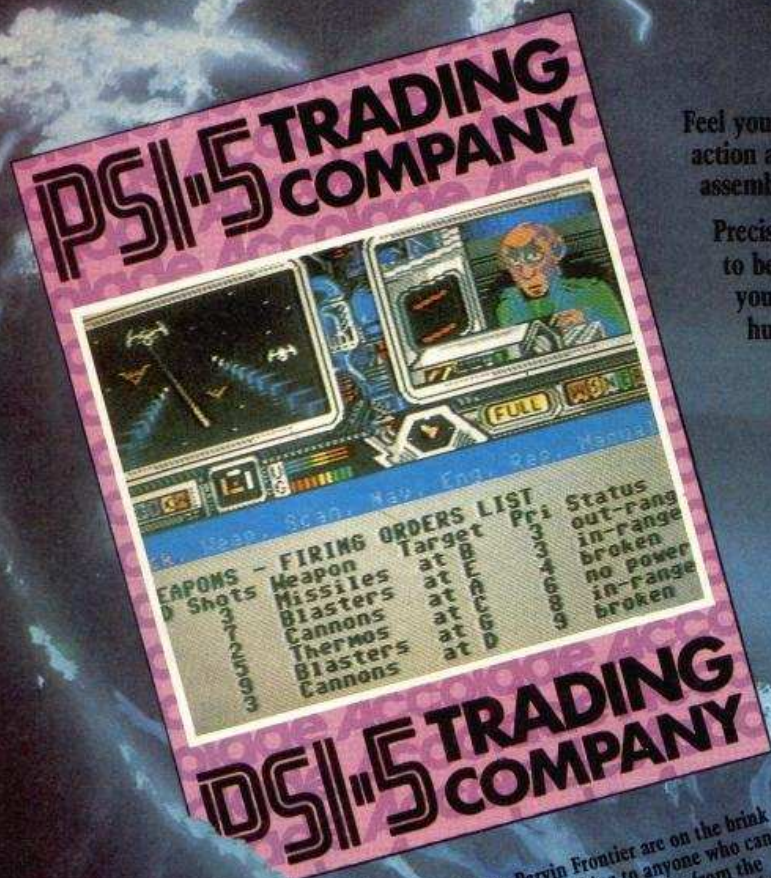

PSI-5
The inhabitants of the Parvin Frontier are on the brink of starvation and will pay anything to anyone who can get through to them with a ship of supplies from the outside world. You take on the challenging role of the Space Freighter Captain and take command with detailed graphics, realistic sound and the finest bridge instrumentation the 35th Century has to offer.
SPECTRUM £7.95 Tape

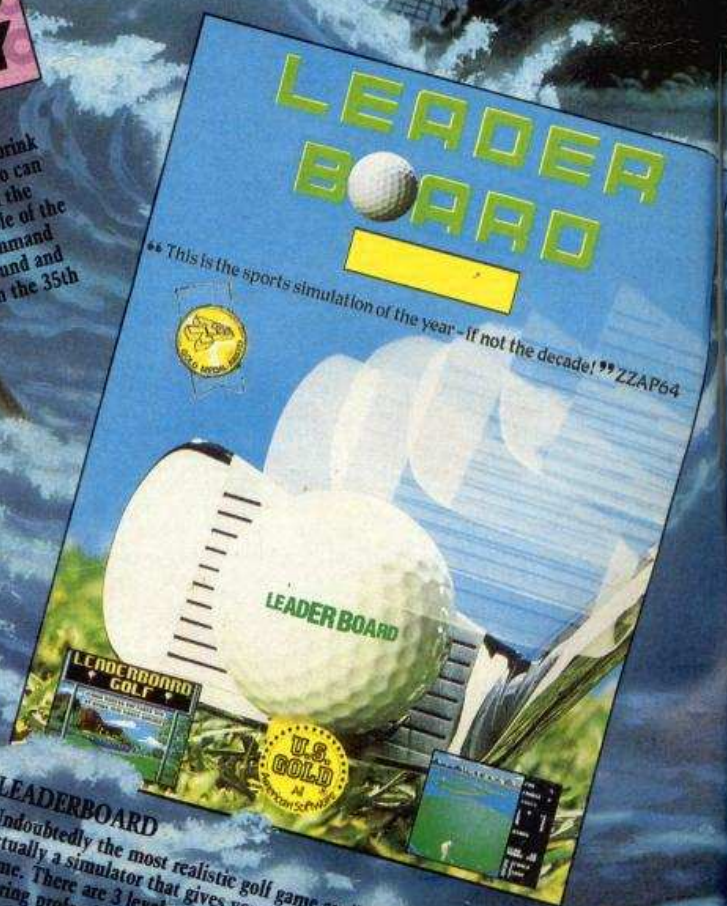

LEADERBOARD
Undoubtedly the most realistic golf game available, Leaderboard is actually a simulator that gives you a true perspective view of your golf game. There are 3 levels of play so you can compete from amateur to touring professional. You'll get all the fun, aggravation and simulation of the golf competition!
SPECTRUM £8.95 Tape

of Scintillating ware

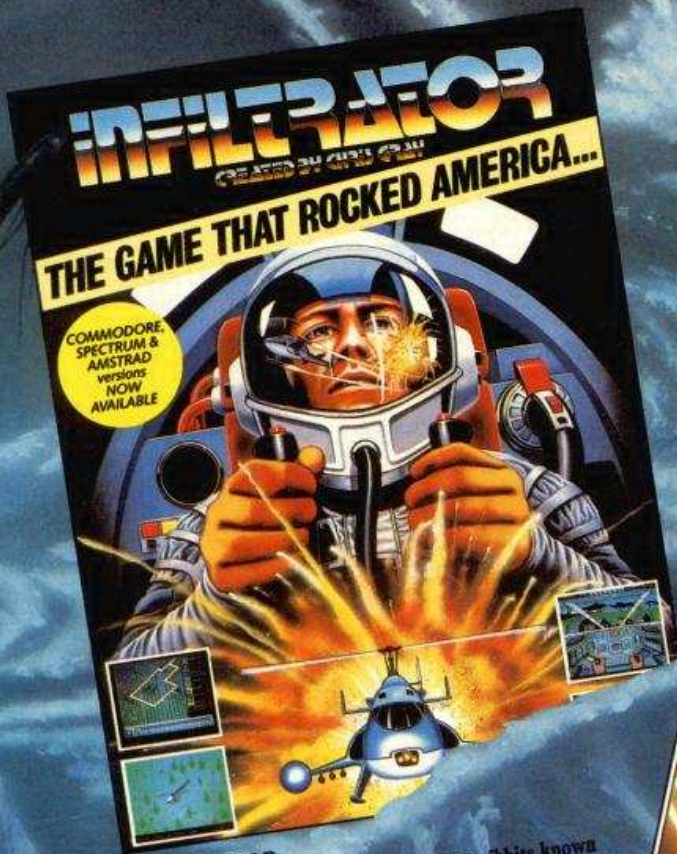

INFILTRATOR
 You are Captain Johnny "Jimbo Baby" McGibbitts known to all as the Infiltrator... Taking off in the Whizzbang Enterprises Gizmo ADHX-1 Attack Helicopter you will have to complete 3 missions flying into enemy territory where you will have to land secretly, infiltrate an enemy base to photograph or destroy one or more objects then fly back to base for the next mission.
 SPECTRUM £9.95 Tape



REVOLUTION
 A unique 3D animation game which puts you in control of a realistic bouncing Ballerball as it overcomes countless hazards to solve intriguing and complex puzzles. There are several ways to solve each puzzle and as you progress through the various stages the solutions become fewer and fewer.
 SPECTRUM £9.95 Tape



U.S. Gold Ltd., Units 2/3 Holford Way, Holford,
 Birmingham B6 7AX. Tel: 021 356 3388



Buy any single or multipack of software costing £4 or more and we'll give you a special American Football Competition sticker. Stick three of these on the free competition leaflet and you can enter the competition.

There are more than a thousand prizes to be won, including the first prize of a two-week trip to America to watch a live American football game.

PLUS if you buy any of the software tapes from the W.H. Smith TopSoft 20 which is marked with a red star you will receive a FREE SHEET of nine NFL team stickers. Don't forget, if you don't play you can't win.

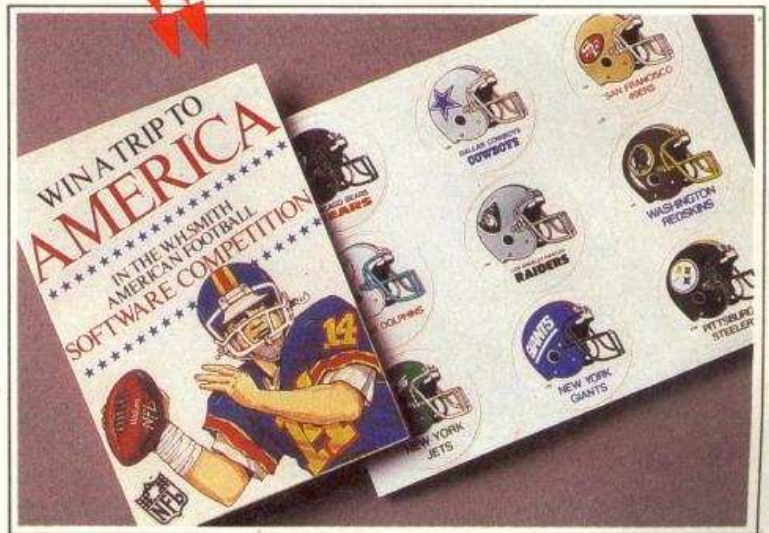

NFL™ © N.F.L.P. All rights reserved.

WHSMITH  HSMITH 

Subject to availability



CRASH

ZX SPECTRUM

Burp! Another issue of CRASH, bursting at the seams with news, reviews and the usual mix of goodies goes staggering off to be printed.

For the second month running, we've managed to persuade our printers to agree to producing a massive 164 page issue — and we'll be putting even greater demands on them for the Christmas Special which should weigh in at 196 pages. Don't forget, the Magazine that bears Lloyd's initials — LMI will have your newsagent's shelves groaning with the strain in December: a whole 80 pages of LMI is going to be strapped to the Issue 36, The 1986 Christmas Special.

A trio of packed issues of CRASH. What better way to round off a year that has itself been packed with incidents — from the Sinclair sell-out, to the Spectrum Plus Two, from the launch of the brave weekly BANG to its demise with a PHUT ... a year crammed with games releases: some excellent, some dire and some incredibly late. New ground has been broken on both the software and hardware fronts, and next year looks likely to be every bit as exciting for Spectrum owners.

This has been a year which has seen CRASH romp to the top of the home computer magazine pile, and a year in which the CRASH staff have come, gone and changed around. We say Goodbye to Sean Masterson this month, who has decided to fight on new battlefields. We say hello to a host of new people in the Art Department, and we've just moved the CRASH office one floor higher in the Towers. From broomcupboard to ex-boardroom — the team's set up for great things the New Year ...

Why this early lookback, rounding up the year? Well the Christmas Special is a festive issue, devoted to fun. Enough of this Editorialising. No more for 1986 ... have a good Christmas! Maybe we'll see you at the 21st ZX MICROFAIR on 13th December — the CRASH team should be there in force, and the whole day's going to be a bit of a party according to the organiser, Mike Johnston ... we might even have a few mince pies on our stand for early visitors!



Graeme Kidd

OLIVER
FREY

TREATS IN STORE

We've been beavering away, working on a whole range of treats for your Yuletide amusement. Three weeks after this issue goes on sale, the bumper annual extravaganza known as the CRASH CHRISTMAS SPECIAL should be in the shops. Without giving away too many secrets, we should be able to offer a reader the chance to win £1,500 to spend on attending a sporting event of their choice anywhere in the world — just one of the extra special competitions that'll have you racking your brains while the Christmas pud goes down...

A fulsome look back on the year is planned for next issue — including a gentle reappraisal of the SMASHes of 1986, news of a cunning device that allows owners of two other computers to play Spectrum games on their machines, and an overview of the musical possibilities opened up to Spectrum owners.

Of course, there'll be the usual crop of reviews, and you can be sure of one thing: unless a game is finished it won't get a review in our pages. Previews — well there are bound to be a few Christmas mega-games that arrive a bit late. What with reviews and previews, we should be able to give you more than a mere inkling of what to expect to see on the shelves as the jingle bells ring out in perfect harmony with cash registers.

Demand for the Christmas Special is likely to be high. Okay, so it's going to cost £1.95 but you do get a completely free magazine courtesy of Lloyd and his colleagues on **LM**. And we guarantee 19.5% extra pages in CRASH next month, excluding the 80 page freebie...

Fill in the coupon and take it to your newsagent if you want to make sure of your copy.

ENSURE YOUR REGULAR COPY OF CRASH

When a magazine is rising in circulation as rapidly as CRASH is doing it tends to sell out immediately and you may experience difficulty in obtaining your copy every month. So the best thing to do is place a regular order with your local newsagent, which you can do by handing him this form.

Please place me a regular monthly order for CRASH Magazine.

Name
Address
.....

To the Newsagent:

CRASH Magazine is published in the middle of every month by Newsfield Ltd, 1-2 King Street, Ludlow, Shropshire SY8 1AQ. Tel: 0584 5851, and distributed to the newstrade by COMAG (08954 44055). Please check with the publishers if you have any difficulties in obtaining supply.

ADVERTISERS' INDEX

Advance Software	64
Argus Press	19
Ariolasoft	96
Beyond	104
Cascade	40
Case	127
CRASH T-shirts/Binders	155
CRASH Mail Order	136
Creative Sparks	98
Creative Devices	138
CRL	93
Datel	53
D & H	81
Domark	32, 33, 137
Durell	142, 143
E & J	43
Electric Dreams	13, 49, 94, 95
Electronic Services	81
Elite	47, 55, 164, 154
Firebird	39
Frel	108
Gargoyle	159
Gremlin Graphics	10, 11, 134, 135
Hewson	9, 61, 77
Imagine	102, 103, 124
Incentive	29, 35, 37
Lerm	133
LM	88
Lothlorien	43
Mancomp	98

Martech	87
Melbourne House	26, 101, 117
Microsphere	151
Mikro-Gen	50
Mosaic	130
NMC	130
NEWSFIELD Classified	76
Nexus	129
Ocean	2, 15, 45, 56, 57, 84, 156
Peaksoft	51
Ross	108
Softech	31, 66, 122, 123
Southway	51
Spectravideo	144
US Gold	4, 5, 24, 25, 70, 119, 163, 131
Virgin	78
Video Vault	113, 108
WH SMITH	6

INDEX TO GAMES REVIEWED IN THIS ISSUE

AntiradPalace	18
Bimblesintech	69
Camelot WarriorsAriolasoft	38
City SlickerHewson	29
CobraOcean	140
DandyElectric Dreams	145
Demon From the DarksideCompass	71
DruidFirebird	146
Dr WhatCRL	128
FirelordHewson	22
FrostbyteMikro-Gen	139
GallipoliCCS	126
GalivanOcean	150
GooniesUS Gold	41
Great EscapeOcean	16
Ice TempleBubble Bus	30
InfiltratorUS Gold	149
180Mastertronic	36
MailstromOcean	132
Miami ViceOcean	28
PhantomasCode Masters	34
Prehistoric Adventure Crusader	69
Room 10CRL	133
Swords of BaneCCS	125
Terra Cognita Code Masters	34
ThanatosDurell	152
Twice ShyMosaic	67
UridiumHewson	20
VampireCode Masters	37
WarMartech	148
XenoA'n'F	27

THE MONTHLY SOFTWARE STAR FOR YOUR US GOLD CALENDAR



FIRELORD

THE HEAT IS ON!

Get spellbound – and hot – with this unique medieval arcade adventure.
Another fast-moving, richly animated scorcher from 1985's Programmer of the Year,
Steve Crow – author of "Wizard's Lair" and "Starquake".



Available for Spectrum,
Amstrad and Commodore
SPECTRUM/AMSTRAD/
COMMODORE CASSETTE: £8.95
AMSTRAD DISK: £14.95
COMMODORE DISK: £12.95

For Mail Order send a cheque P.O. to
Hewson Consultants Ltd. Order by Credit
Card sending your Access/Barclaycard
number, and a specimen signature. Don't
forget to enclose your name and address.



Free Gift with every purchase.
Offer closes 31st December.

HEWSON

56b Milton Trading Estate, Milton, Abingdon, Oxon. OX14 4RX

As part of our continuing development of innovative software we are always happy to evaluate software sent to us with a view to publication.

GREMLIN

ALWAYS AHEAD

Footballer of the Year

The game to answer every boyhood dream - the chance to make it to the very top of football stardom. Starting on your path to glory as a 17 year old apprentice with a Fourth Division team and only £500 and 10 goal scoring cards in your pockets, the footballing world is at your feet. Adopt the identity of a professional footballer and develop a career through the ups and downs of match days, transfer deals and injuries etc. Display your talents in Football League, UEFA, FA and Milk Cup games and then if you're good enough the ultimate accolade of your sport, the Footballer of the Year Award.

From First Division giants and opted to stay with Rovers. This promising centre-back has signed a new contract with team manager Derek Thorpe announced today.

ALBERT DEBUT

FOOTBALLER OF THE YEAR

SALE join overs for Record **BANKS**

INJURED

English International striker KENNY MORSE could be out of action for the rest of the season because of a leg injury.

The injury also threatens his chances of making it into the National Squad for the world later in the year.

Morgan, aged 29, has missed a large part of this season because of several other injuries. He pulled his leg muscle yesterday in an exciting game, after scoring a spectacular goal against Rangers.

Footballer of the Year Fr

C16 + 4 MSX Spectrum 486

£6.95 £7.95

Amstrad, BBC/Electron
Atari CBM 64/128

£9.95

Avenger

C16 + 4 CBM 64/128

MSX Spectrum 486

Amstrad
£9.95

First came "The Way of the Tiger" the martial arts classic in which you had to prove your physical skills to become a Ninja. Now you have to prove your supreme mental agility in the second part of the Way of the Tiger saga "Avenger", the ultimate arcade adventure. Yaemon the Grand Master of Flame has assassinated your foster father Hattori and stolen the Scrolls of Ketsuin. You have sworn to the God Iwao that you will avenge Yaemon's murderous act and recover the sacred scrolls. Your enemies are many, varied and all are deadly. All your skills courage and nerve will be called upon when you begin the final conflict in the Great Keep. Good Luck... only the brave hearted will survive.

Avenger (Way of the Tiger II)

Bonus

C16 +

£6.95

Available N

Way of the

C16 +

£9.95

Available N

Thing or a

C16 +

£6.95

Available D

Gremlin Graphics S

Alpha House, 10 Carver Street S

GREMLIN

OF THEIR TIME

Future Knight Trailblazer

48K C16+4 MSX Spectrum 48K
 £6.95 £7.95

CBM 64/128
 Amstrad

£9.95

Disk

128 Amstrad Disk

48K CBM 64/128

Disk

£14.95

Future Knight

Arise Sir Randolph to take up the challenge of death that has befallen the fair maid Amelia, held in the evil clutches of Spobott the Terrible. Acting upon an inter-dimensional distress signal from the galactic cruiser SS Ruzbickiot, don your Dimrobot Mark IV attack suit and venture forth in pursuit of your beloved's captors. Defend yourself nobly against the Beneska Security droids. Fight your way through 20 grueling levels onto the planet's surface into Spobott's castle where the fate of Amelia lies with the outcome of your mortal combat with the awesome Flencho-droid. Is there any gallantry and bravery left in this modern day universe?

Available
 November

FUTURE KNIGHT

TRAILBLAZER

Thunder

164

£6.95

November

The Tiger

164

£9.95

November

Spring

164

£6.95

December

Gremlin Software Ltd.,
 Sheffield S1 4FS. Tel: (0742) 753423

Thunder into the unknown at a breakneck speed, pushing your reflexes to their limits in this definitely exhilarating journey that's not one for the faint-hearted. Roll left, roll right, avoiding the endless chains of doom that lay in and around the squares of mystery. Squares that will sometimes slow your progress, on occasion with fatal consequences and sometimes speed up unexpectedly or make you jump automatically. Keep a keen eye on the clock as the quicker you complete your task the higher will be your bonus. CBM 64 version is an amazing 2 player simultaneous game. Amstrad/Disc version contains extra features.

Trailblazer

KERRASH!

N·E·W·S·I

20th ZX MICROFAIR

Tim Gilberts of GILSOFT proudly displays the home-made tome used to advertise THE PROFESSIONAL ADVENTURE WRITING SYSTEM



Christopher Stone made the long trip down to London and arrived at the CRASH Stand in search of some headgear...

MORE MICROFAIR MADNESS

Well, didn't we have a luvverly time when we all went down to the 20th ZX Microfair?

This time the Fair was held in the Central Hall, Westminster, rather than its more regular venue, the Royal Horticultural Hall — just a bit further down the road... Apparently, the Horticultural Halls were already booked up, so it was a case of cramming the show into several rooms and various floors at Central Hall, or having no show at all.

Although slightly disorientating at first for regular Microfair attendees, once you got the geography of the building sorted out, it wasn't too bad scampering between floors. But you could suddenly find yourself bursting in on a Methodist Bible Class or a choral rehearsal

by mistake... Quite a few folks said they actually preferred the cosy atmosphere to the rather cavernous, high roofed Horticultural Halls, which just goes to show you can't please all of people, all of the time!

As usual, the Fair was crammed with people — all shuffling round an increasingly stuffy and overheated hall packed with stuffy and overheated retailers flogging their wares at knock-down prices.

New products were few and far between, however. *The Professional Adventure Writing System (PAWS)* was due out 'real soon now', according to the fellows on the GILSOFT stand, who explained they'd been up half the night making a monster display book with which to decorate their stand.

Among wonderful facilities, this new utility is said to have a really amazing parser which recognises complex sentences, including nouns, adjectives and prepositions (LMLWD). There is a 1500 word vocabulary, RAM save/load, and 256 counters/flags, diagnostics, and time-outs that between them allow the user to create 'real time' adventures. All in all, it left Sean (FRONTLINE) Masterson running for his phone making 'I've got to have a copy of

that' type noises.

PAWS is due out in two forms: a split pack for the 48K Spectrum with one pack containing the text editor and the other the graphics routines; for the 128K Spectrum, the two halves are combined in one program. On the 128K Spectrum, PAWS allows adventures that occupy up to 110K to be written, so some monster games should be on their way. £22.95 ought to secure either version roundabout the time you read this.

As usual, there was plenty of hardware on show — and a few Plus Twos were even on sale! ROCKFORT PRODUCTS introduced their disk interface for the Spectrum — *The Disciple*. It includes a Centronics parallel interface which gives full screen dumps, two joystick ports and an Interface-One-style network port. The commands are claimed to be Microdrive compatible, so any program designed to work using the Mic-

rodvice should work with the ROCKFORT interface. A 'snapshot' button allows programs loaded from cassette or Microdrive to be saved to disk — up to 16 to a side. *The Disciple* will set you back £84.75 including VAT — all you have to supply is your own Shugart compatible drive and the system is up and running. ROCKFORT SYSTEMS of 81 Church Road, London NW4 4DP have further details and TECH TIPS might be able to take a peek next month...

ROMANTIC ROBOT had made the Dutch connection in time for the Microfair, and were demonstrating a new Spectrum digitiser they're importing from the Low Country.

The new little black box goes by the name of the *Videoface*, and captures pictures at a rate of three frames a second, saving the last six screens scanned. The final price has not yet been set, but should hover around the £70 mark.



With twenty MICROFAIRS under his belt, Mike Johnston busily took stand booking for the celebratory 21st ZX MICROFAIR. The 13th December is the date for your diary, and it's back to the Horticultural Halls...

D—DOUBLE TAKE

A cunning new game is nearing completion in DENTON DESIGN'S Liverpool offices: *Double Take* should be published by OCEAN any day now.

An evil personage has come to dominate a universe which is the

mirror image of the universe in which we all live and play games. Bored with being the Big Cheese in his own universe, the antihero has taken advantage of a wormhole in reality created by an experiment in a physics lab, and now seeks to gain entry to our universe and become an evil Big Cheese all over again.

The locations in our universe are mirrored in the baddy's universe, and every so often you find yourself transported from a location to the corresponding place in the opposite universe. Objects have been displaced between the two universes. To restore stability they have to be taken to their rightful universe and deposited in the cor-

rect place. And it's no use hanging around in the negative universe holding an object that needs to be taken to the positive universe and waiting for the transportation sequence — objects held during the journey flip to their mirror image unless they have first been 'fixed' by taking them to a sparkly cloud...

That white coat in the middle of the screen is, in fact, you! In the Anti-Verse, lurking in the bathroom

What's this. Unreality is fading — the link between the universes has been activated.....things fade away

The normal universe begins to take shape around you...

In the bathroom again, but this time in our universe, not the evil, mirror-image one...

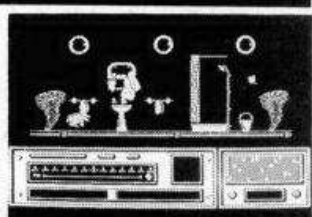
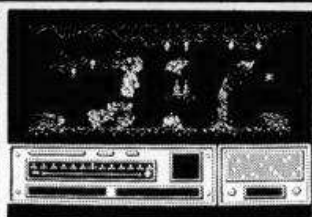
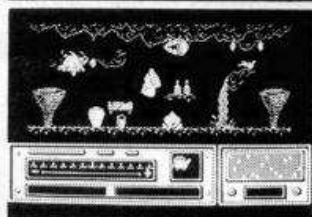

LATE ARRIVALS

Stablemates *Fairlight II* and *Artist II* arrived from THE EDGE — they were finished a little too late to make it into the review section, so here's a screen shot or two to feast your eyes on while you wait for the full reviews.

Fairlight II will look very familiar to fans of the original: the same *Worldmaker* system has been used, but the size of the playing area has been doubled and the game loads in two parts on the 48K machine, fitting into the 128K after one huge load.

In the game, Isvar embarks on another mystical quest. Up to five items may be carried, depending on their cumulative weight, and as usual, the place is packed with baddies who have to be put to the sword. The setting is rather more pastoral, with trees and leafy

glades replacing the uniform interior locations of the original. Clearly a game *Fairlight* fans won't want to miss.

The *Artist II* also arrived, courtesy of the productive **Bo Jangeborg** and his Spectrum. You may have seen this product reviewed elsewhere some weeks ago, but, according to Dr Tim from THE EDGE we are "the first magazine ever to see the final commercial version."

The tome-like manual, still in final draft form (only just finished, you see) was whisked away by one of our tame techno minions, and if we can persuade him to let go for long enough to put finger to wordprocessor, the definitive review should arrive in time for the Christmas Special...

One of the demo screens from THE ARTIST II, illustrating the pull-down menu control method

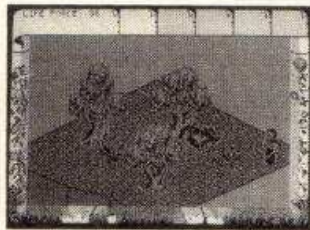

Isvar confronts a four-legged member of the local fauna in FAIRLIGHT II

DID THE EARTH MOVE FOR YOU? NO COMMENT!

According to another Spectrum magazine, the world should have been shaking by now, as a new force filled the senses. "Computer magazines won't ever be the same again," its readers were told in October. Purchasers of the magazine, however, may have felt a little aggrieved when the Newlook November issue "exploded into the shops".

It was "going to have 146 pages" — "A simple fact", according to the announcement. Justifying the 2 pence price rise, the blurb writer insisted that "we've

David Kelly, snapped at the ZX Microfair: "No Comment"



also put the number of pages up — by over 20 percent".

Asked to comment on the arrival of the November magazine, which sported 126 pages (Fact: a rise of 6.8%, and some 15 pages slimmer than his readers had been promised), its editor asserted that his December issue would be 146 Pages large. "No comment", was his response when asked how he would approach any complaints from November purchasers who spent their £1 and realised they hadn't got quite what they were promised...

WINDOW WARS

IJK SOFTWARE, returning to the Spectrum games scene after an absence of over a year immediately ran into a little trouble with its latest release, *Crime Busters*.

According to a spokesperson for MASTERTRONIC, the game is "a blatant rip-off" of the budget hits written by **David Jones**: *Knight Tyme* and *Spellbound*.

Crime Busters employs a pull-down menu system that bears more than a passing resemblance to the *Windowmation* technique of

BANG GOES PHUT!

A few days before *Bonfire Night*, BANG fizzled out. The weekly newspaper published by SPECIALIST RETAIL PRESS — the firm behind trade paper, CTW — survived in the cut-and-thrust marketplace of newsagents' shelves for a mere ten weeks.

Launched at the PCW Show in September, BANG set out to cover music, video and television as well as computer games — *Computer Gamer* Editor, Tony Hetherington was tempted into the BANG fold to head up a computer section. The decision to close BANG, an ambitious attempt to take on the weekly market with an A3 tabloid paper, was taken just before the tenth issue was due to go to press.

"Our little dream is over," commented BANG Editor, Greg Ingham ruefully, "all that is left for me to say is many thanks to our readers."

BUTCH HARD GUY LIVES!

A spoof beat em up is on the way from a new outfit called FUTURE CONCEPTS. In *Butch Hard Guy*, subtitled *Who Cares Who Wins*, the aim is to progress through 20 screens, kicking and punching combat droids until the bad guy's lair is reached. Mr Fu (for it is he) lives in a castle, and BHG is so hard he has to destroy Mr Fu's castle with his bare hands.

Early January should bring the release of this comedy combat extravaganza, scheduled to appear on the ADVANCED SOFTWARE PROMOTIONS label. A trio of Butch Hard Guys is behind FUTURE CONCEPTS: David Thompson, Sean Lally and Dennis Mulliner.

Supertuff hero BUTCH HARD GUY fights his way towards the lair of the evil Dr Fu...

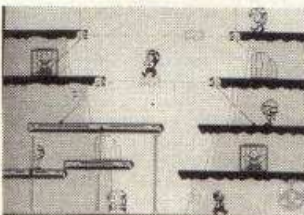

game control developed for *Magic Knight*, and even uses the same character set.

Following an approach from MASTERTRONIC, IJK have withdrawn their new release and are currently considering their position. MASTERTRONIC's spokesperson was unequivocal: "They must be out of their heads, trying to have a quick clean up before Xmas and then bugger off afterwards." Unlikely to be the case, considering that IJK is certainly no fly by night (or even Knight) firm. They have been around for over five years...

Strip Teasers

Star Raiders II™

The Great Galactic Adventure Continues

Star Raiders II is a trademark of Atari Corp.

COMING SOON ON

SPECTRUM
COMMODORE
& AMSTRAD
HOME COMPUTERS

Electric Dreams

SOFTWARE

Electric Dreams Software,
31 Carlton Crescent,
Southampton, Hampshire SO1 2EW.
Tel: (0703) 229694

Fear & Loathing



THE EAGLE IS LANDING

It's 2.51am and freezing cold. I had one and a half hours sleep last night — trying to meet various deadlines — and tonight I daren't take any, because I'm booked in on a nine o'clock flight to Sweden. I've also shaved my head. And you'll want me to talk about computer games now, won't you?

What a month it's been. No rest for the wicked as I emerged from the unreal mists of PCW. Remind me next year that I'm not attending that Show. It just fills me with paranoia and bad craziness. I rant. I rave. I enjoy myself too much. And I wake up outside Camden Palace, where red capped youths are trying to sidewalk surf (skateboard for the un-hip) up the stairs. Turns out its the **LM** launch and I'm the honoured guest.

Actually, I'm not an honoured guest at all. I'm not even invited. But for once the boys from Ludlow seem in a good enough mood to forgive my transgressions with late copy. (The previous column was sent in at the last minute via a Fax machine. Thanks to an anonymous company for lending me the services of this invaluable device ... even if they didn't realise that they were!)

Once inside I was fascinated to find a distinct social divide between us and them. They were the **CRASH**, **ZZAP!** and **AMTIX!** readers who had foolishly jumped at the chance to get a rare and wonderful invite to the launch. They were marooned at ground level (but if they try to skateboard up stairs, what else do they deserve?) and harangued by an alternative comedian; his alternative to comedy being that he wasn't funny!

Meanwhile, we were the potential advertisers, editors and representatives of the software industry, and we had a bird's-eye view of the carnage below. Really, it was rather like watching the Christians and lions. But I have too tender a heart, and hurled the odd chicken bone at the starving teenagers below. Sadly, I didn't manage to hit any.

It was an interesting diversion, indeed, and thanks to a little bribery and a lot of corruption, it looks like **LM** will be thrilling its audience with my coherent ramblings.

I'm not sure what I'll write about though. I mean, here I'm supposed to write about computer games ... so I don't! When I'm not supposed to write about anything in particular, it's far more difficult.

Not that I'm losing any sleep over it. In fact I was woken from a deep slumber a few days later by the phone. "Darling," said a voice I immediately recognised. "Unusually affectionate for you, Michael", I told the ubiquitous Baxter. "No", he tittered, "The Darling family. We're launching their new **CODE MASTERS** budget range today. Be there or be somewhere else. "Okay", I said, slipping out of slumber and into some trousers, "Where is it?" "Your favourite", the ubiquitous Baxter replied, "No 1 Holsten."

Of course, Baxter was right. I

Hunter S goes in search of a Hoover to solve a perennial problem ...



have great affection for this London watering hole, though it got a black mark for the desserts this time. Why, oh why, did we get cold, pink rice pudding? Perhaps the man from Africa News knew, but he wasn't letting on. Still, I'll say this for Baxter, he can certainly pull the world press if he does your PR.

CODE MASTERS looks promising. The Darlings appear to have recognised the basic rule of budget software ... give the punters something good and they'll flock to you.

Nice to see my erstwhile colleague, **Leslie (LB) Bunder** there too, even if he did keep looking behind him and muttering something about the 'New Man' being after him. Obviously he's involved in another example of investigative journalism at it's very best. He told me something about the fact that he's becoming a limited company, so that his cards will now bear the motto *Leslie Bunder Limited*. Couldn't you make that PLC, LB?

The endless patience of Baxter, demonstrated by this latest invitation, was thrown into perspective soon after. I had to invite myself to **ACTIVISION**. Maybe the Volvo that received the multi-coloured paint job from a great height last time I was there belonged to somebody in the company. Anyhow, their failure to notify me of this pre-Christmas preview meant that I arrived late, and the first delivery of pizza had already been consumed. Not surprising as John — the Trap Door — was there. Still, the good burghers of **ACTIVISION** made amends for their craven attempt to avoid my company by sending out for yet more deep pan with extra everything, and very welcome it was too. It also meant that while I was stuck, waiting to do my duty as gourmet correspondent, they could force me to look at a computer game!

Actually, this was rather interesting. Remember how they said *Little Computer People* couldn't be done on the Spectrum? Well, they've just gone and done it! Quite how well they've done it was difficult to say from this very unfinished version, but if you've ever hankered after a little computer person to starve to death, you don't have to wait long.

All this while a Very Big Computer Journo' was pestering me to give him a mention in this column. He's obviously seen how other people who have been graced with a mention have gone onto better things. But I think I'll have to keep this fellow out of it. Anyhow, the combination of extra onions plus the Little Computer Hippy's garishly coloured house was beginning to do odd things to me.

That's why it was a mistake to subject myself to **RAINBIRD's Star Glider**. I mean, it's lovely to mention that the divine **Clare Edgley** is now no-longer working for a rival mag, but doing PR for **RAINBIRD**. But her gentle voice did nothing to prepare me for the assault that hit me when we finally got the preview program to load.

Lulled into a false sense of security I took the joystick and started to fly around a planet's surface. Within seconds I was blasting away, fighting for my life, among animated vector graphics. The finished *Star Glider* should feature Clare's voice, which sort of makes her a Star Bird. It will be massive!!!

Enough! Too much, even. I rushed home to the warmth and comfort of the latest **CRASH** and what did I find? Yet more fan mail. What is this? Am I doing something wrong, to receive such adulation, or is this really a nation of degenerates who find my sort of behaviour amusing. For all our sakes, I hope so.

Spurred on to greater excesses, I called in on my friend and part time hair-dresser, Laszlo Leys. Once I'd imbibed a sufficient amount of local anaesthetic, he shaved my head to shiny perfection. I no longer have any need of Head and Shoulders for my dandruff — I just use a hoover.

Then I booked my Swedish flight, and in less than eight hours I'll be in the arms of my beloved. Quite how she'll react to the absence of follicles, I'm not sure, but keep an eye on **LM** if you want to know what it's like to be bald in Stockholm.

That's that. I must go pack a toothbrush. Yours in fear and lathering

Hunter S. Minson
(The Great Bald Eagle)

AMSTRAD 48-95
ZX SPECTRUM 47-95
COMMODORE 64 48-95

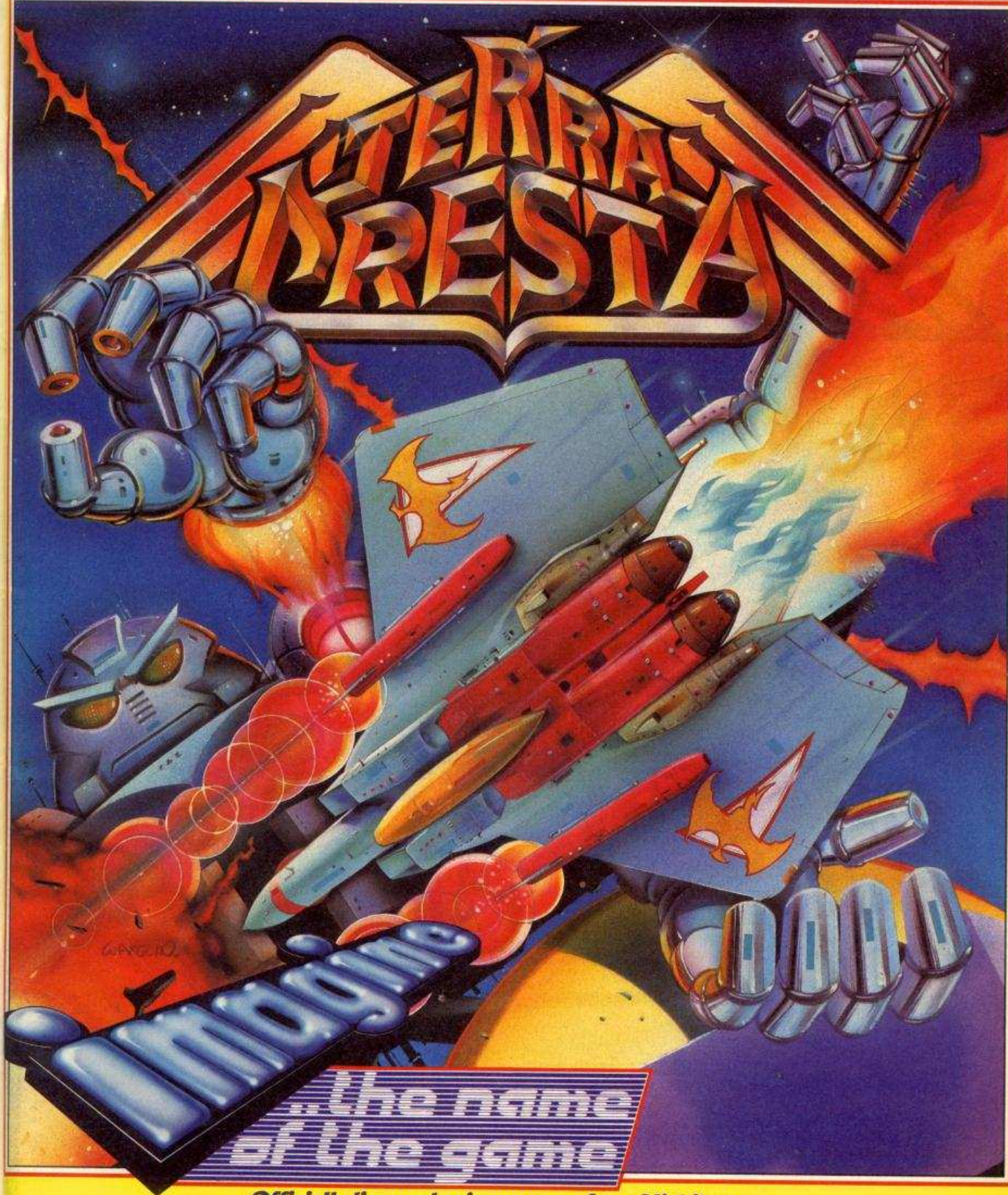

MOON CRESTA
...the name
of the game

Officially licensed coin-op game from Nichibutsu.

Follow up to Moon Cresta. Now for your home computer.

Pilot your space fighter over the planet eliminating all alien life forms on its surface. Build up fire power on board as you dodge missiles launched from land silos and under-sea bunkers. Face the giant Death Star at the end of each orbit. You will need nerves of steel to pass this test!

Imagine Software (1984) Limited - 6 Central Street - Manchester - M2 5NS - Tel: 061 834 3939

DENTON DESIGNS have been rather quiet recently, but with a pedigree that includes *Frankie Goes to Hollywood* and *Shadowfire*, they're back in the fray with a game for OCEAN.

You play an English POW trying to escape from a German camp in the last war. The main screen display reveals a section of the scrolling prison compound — or if you are indoors the room is shown from the usual 3D game angle. To begin with it's a good idea to leave the controls well alone — the hero goes about the daily grind of prison life with the other prisoners and you get an idea of what's going on. A normal day consists of parades, meals and exercise periods, all marked by a bell displayed in the status area which rings out loud and clear. A message window gives an update on events in the camp and explains the reason for the bell's clamour.

A flag flying from a pole to the left of the main play area serves a number of functions. The higher the flag flies, the higher the morale of the central character. Whenever a Red Cross parcel arrives or the hero succeeds in picking up or using an item of escape equipment, his morale improves. Morale is lowered with searches and arrests and gradually diminishes as time elapses. Once the flag

reaches the bottom of the pole, the potential escapee loses his will to rejoin the war and becomes resigned to plodding around the

CRITICISM

"The Great Escape is definitely one of the best games I've ever seen on the Spectrum. I was extremely happy to see that OCEAN have introduced a scrolling play area — the flip screen method annoys me. The playing area is superbly drawn, with some very large and detailed buildings — all with 'en suite' stove and cupboards, and even a chimney to let those heated arguments out. The game is brilliant fun to play as you actually feel that you are trapped in the camp. There are lots of clever features and the game is very easy to get into — I found that I could explore a large area of the camp and tunnels without any keys or wire cutters. The instructions are well written and complement the game well. The Great Escape is bound to be a major contender for the top Christmas game this year."

camp with the other prisoners. You lose control, and have to start a new game.

While the flag is green you have limited control and the hero can only be searched by the Camp Commandant — should he find any contraband, it's off to the cells, so it's wise to keep out of his way. The flag turns red as soon as the escapee breaks with routine and moves off limits. While the flag is red objects can be picked up and dropped, but the would-be escaper is liable to arrest and search by the guards.

Once you've established the routine of the camp, it's time to play for real and start planning the escape. Unfortunately, only two items can be secreted in the old greatcoat, so it's a good idea to find safe hiding places for useful items — if the guards find objects, they confiscate them, returning them to their original location.

The guards are fairly predictable

CRITICISM

"Some filmation games have nothing going for them except pretty graphics and completely lack any sort of enjoyable gameplay elements. The Great Escape, I hasten to add, is not one of them! It does have superb graphics, but also plays very well — quite well enough to justify long hours of playing. I don't know how long it'll take an average player to complete, but I will certainly play it as much as I can: presentation is of the highest quality; the graphics are superb, and the game is very playable. Well done OCEAN!"

fellows — once they've been assigned a patrol route by the Commandant, they follow it regularly and can be timed. So long as you don't cross their line of sight they won't notice you, but they are mindful of the wrath of the patrolling Commandant who moves around the camp inspecting them, so the guards keep alert. To begin with, security is fairly lax, but the Commandant steps up security when the hero is caught out of bounds and avoiding the guards becomes trickier. During the night, searchlights sweep the courtyard and prisoners outside the huts get arrested on sight. Maybe wearing German uniform might help here?

CRITICISM

"The Great Escape is possibly the best game in this vein that I've ever played. To get wholly engrossed in the game and its plot all you have to do is read the instructions and watch your character wander around the camp doing his daily chores. By the time you understand how the game works there is no way you can possibly leave it alone. The graphics are superb, the characters are excellently animated and the playing area scrolls well and is expertly detailed. The sound is a little dull — there is a beeped version of 'It's a long way to Tipperary' on the title screen but not much in the way of spot effects during play. I loved The Great Escape and I'm sure you will too if you give it the chance."

Points are awarded for escape attempts and for collecting and using objects. There are a number of routes out of the camp: use a tunnel, cut the wire, or bluff your way past the sentries at the main gates. Whichever way you go out, once outside you'll need a compass and some papers or you won't get very far...

COMMENTS

Control keys: redefinable: up, down, left, right, fire
Joystick: Kempston, Cursor, Interface 2

Keyboard play: really easy to use

Use of colour: minimal, understandably

Graphics: excellent scrolling, minute detail

Sound: not up to the rest of the game's high standards

Skill levels: one

Screens: large scrolling play area

General rating: An excellent game — one to buy

Use of computer	95%
Graphics	96%
Playability	96%
Getting started	95%
Addictive qualities	96%
Value for money	94%
Overall	96%



THE SACRED ARMOUR OF ANTIRIAD

Producer: Palace
Software:
Retail Price: £8.95
Author: Dan Malone

The place is Earth, the time is the far future. There has been a terrible nuclear war which has utterly destroyed all vestiges of mankind's civilisation on Earth.

Into this primitive, defenceless world comes a race of invading aliens who want to plunder the Earth for its mineral wealth. Only one hope exists. Tal must penetrate the Alien stronghold and destroy their powersource deep within a strongly fortified volcano.

To do this, Tal must locate the Sacred Armour of the Antiriad. This is in fact a pre war battle suit. This enables Tal to survive the intense radiation within the volcano and the attacks of the mutant guardians who defend it.

In this arcade adventure, there are two distinct styles of play. When Tal is running around on his own, he can run, leap, and throw rocks. Any damage he sustains saps him of his endurance, and can eventually lead to the loss of one of his five incarnations. Getting about is a question of leaping from ledge to ledge, all the time working out the best way to get various objects needed whilst avoiding the meanies.

Once Tal arrives at the suit carrying the gravity displacers, the controls then become slightly different. Here he is not only protected from the ravages of the meanies and the radiation in the volcano, the suit also actually cures Tal of any injuries sustained. He then floats around in the suit, using the usual joystick directional moves. Once our hero has found the Pulsar Beam, he can deal with the meanies pretty quickly.

Some meanies follow set paths, whilst others materialise, float aimlessly in space, and then suddenly make a beeline for Tal, so it is best to deal with these quickly. On some screens, Tal encounters an enemy alert robot. Unless he deals with this quickly, it summons a couple of meanies to the spot.

But moving around in the suit carries other problems. Contact with meanies depletes the suit's energy. Fortunately there are a few recharge cells scattered around the place with which the suit can be recharged. Also, some parts of the volcano contain impenetrable barriers through which the suit cannot pass.

If Tal wants to get in to the suit, he simply moves over it and then turns to face the front of the screen, he is then 'res-ed in' to the armour. To get out of the armour, he stands the armour on a convenient ledge and then just moves left or right. If the suit's energy is depleted, it drifts down to the nearest ledge.

The status area at the bottom of the screen shows the score, the energy level of the suit and Tal's stamina level as horizontal bars. A meter measures radiation, which generally increases as Tal ventures deeper into the volcano. A small panel reveals how many of the four components of the suit have been collected, and a scrolling message window carries warnings and the occasional helpful hint.

The final object of the game is to get right to the top of the volcano and penetrate the enemy stronghold and set off the implosion mine.

CRITICISM

● "Antiriad is an absolutely lovely game. The graphics are superbly done, very colourful and detailed. The screen is very well laid out and gives the game a good atmosphere. The control panel is drawn extremely well, and despite the single colour format, gives a good idea of 3D — the scanners it contains are very informative and easy to read. The movement of characters is very fast and smooth,



despite them being nearly half the play area high. Antiriad contains fast and furious action combined with a small bit of adventure instinct. I found it a pleasure to play, but at £9.95 it is quite costly."

● "PALACE have only released a few games on the Spectrum and, while most of them have been very good, Antiriad is the best yet. The game is excellently presented, the scenario (in comic-book form) sets the scene very well and the attract mode is also first-class. Perhaps the playing area is a little on the small side... The graphics are the best that I've seen this month. The characters are minutely detailed and fantastically animated, and the backgrounds are very pretty. The sound is also very good with a tune on the title screen and lots of worthy effects during the game. I strongly recommend Antiriad, it is fun to play and very original."

● "It seems this month that I have done nothing but review arcade adventures. Antiriad really stands out. As far as instructions are concerned, the comic book is really well worth reading, but for me, the game's high point is the astounding animation of the main figure who stomps, leaps and throws the place about, amazingly well. Colour is used to good effect, and the whole thing fits together in a way which makes it fun to play and nice to look at."

COMMENTS

Control keys: redefinable: up, down, left, right, fire
Joystick: Kempston, Cursor, Interface 2

Keyboard play: responsive
Use of colour: excellent
Graphics: just about the best we've seen

Sound: good title tune and a lot of jolly spot effects
Skill levels: one
Screens: 69

General rating: A pretty addition to any arcade adventure fan's collection

Use of computer	90%
Graphics	94%
Playability	88%
Getting started	87%
Addictive qualities	87%
Value for money	86%
Overall	89%

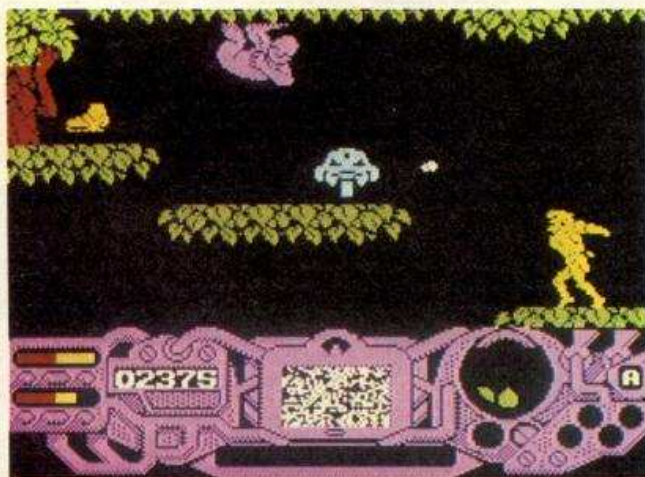

In the jungle, Tal hurls a rock at the meanies. He's got to get to those anti grav boots and get leapin'

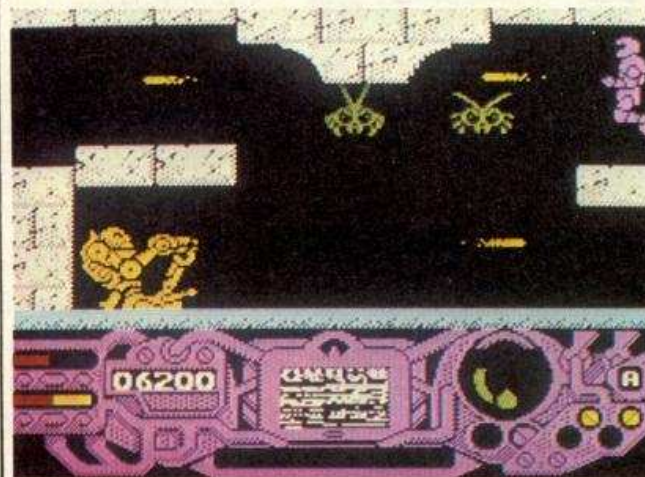

In the suit, Tal's picked up the blaster and gets on with sorting out a few meanies in the city

The fastest sci-fi arcade game yet.

AMTIX!
Arcade

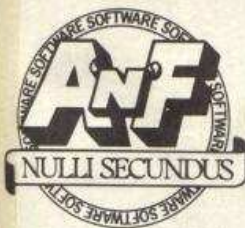

Victory House, Leicester Place,
London WC2H 7NB
Telephone: 01-439 0666

Spectrum
CBM 64
and Amstrad: **£8.95**

Can you become Earth's Xeno champion?

1 or 2 player
option.

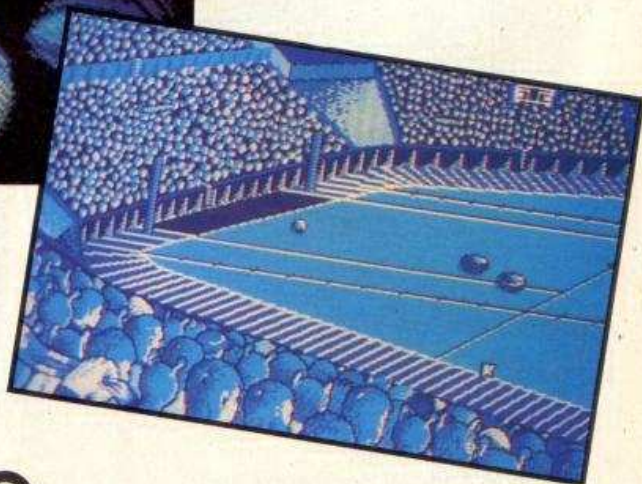

Zooming along in a Manta it's the defences of a Copper Dreadnaught Cam's taking on at the moment

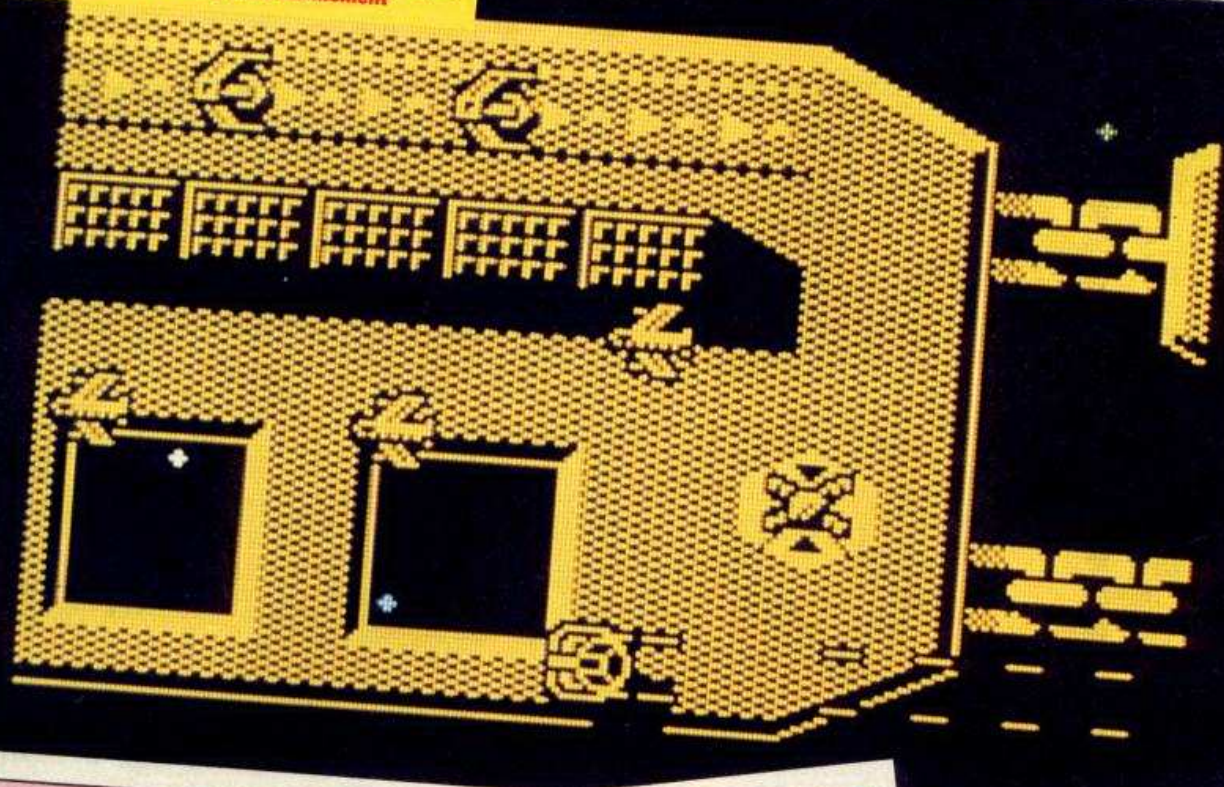

Nasty alien pilots do their best to thwart our Cam as his Manta zooms along the hull of the first mineral-thieving space leviathan



Those black gaps in the middle of the runway were enemy fighters until our Cam blasted them. Always going for the High Score, our Cam. Better watch out for those pylon doobries at the top and bottom of the screen, though

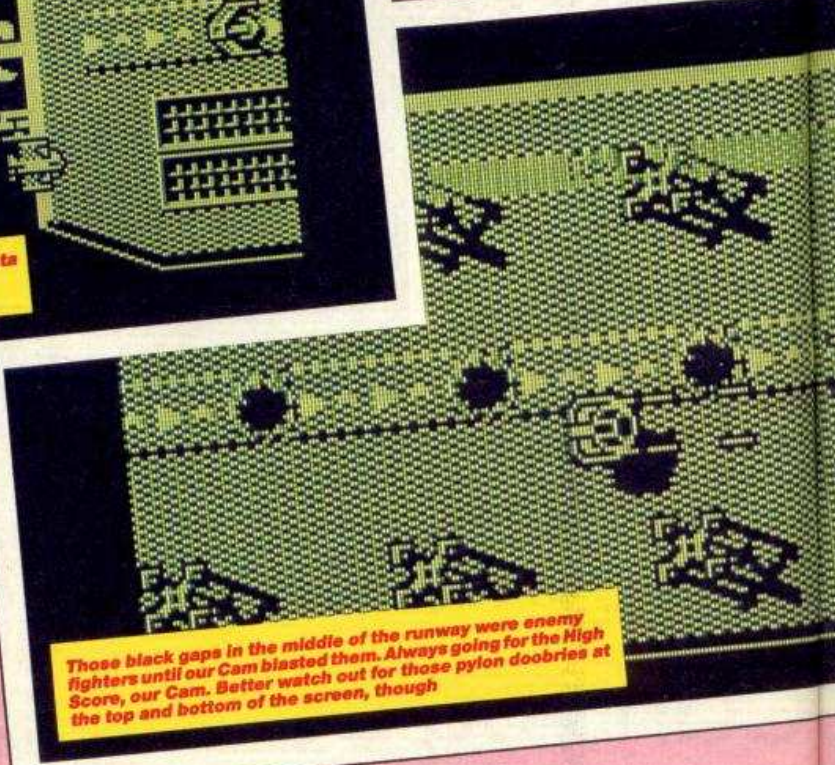

Producer: Hewson
Retail Price: £8.95
Author: Andrew Braybrook and
Dominic Robinson

In the Commodore game they said couldn't be done on the Spectrum has finally arrived. Dominic Robinson, a newcomer to the HEWSON fold of programmers, has converted Uridium from the original that was designed and written by Andy Braybrook.

High above a planet's surface huge battle cruisers called Dreadnaughts silently move into combat position. The reason for this sudden and unannounced invasion is simple; the Dreadnaughts need vast amounts of fuel. In order to get it, they must tap planetary

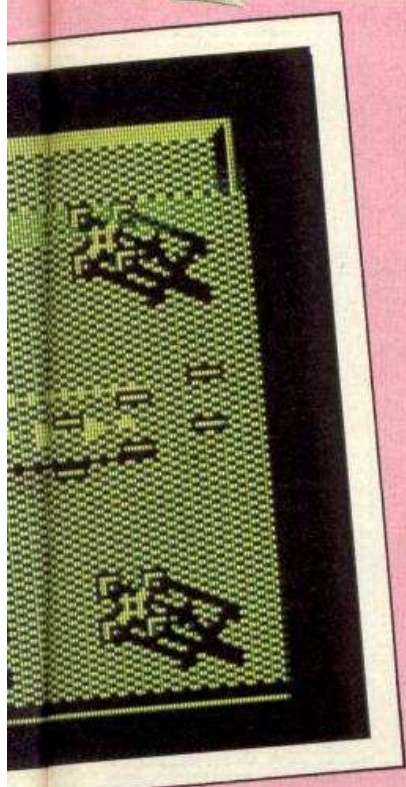

cores and drain them of minerals. Naturally, this will result in the destruction of each planet in the sector if nothing is done.

Your task as a super pilot is to fly your nifty Manta over the Dreadnaughts and make space safe by destroying each one in turn. The odds are stacked heavily against you, but size is on your side. The Manta is small and versatile enough to fly very close to the Dreadnaughts and it can attack the fighters that patrol the ship's hull. The aim is to wipe out all the ancillary craft, inflict as much damage as possible and destroy the giant space ships.

However, there is a severe drawback to this plan of action. Those fighter pilots aren't just going to sit back and let you get away with all this carnage and mayhem — they're out in force and they're gunning for you. Luckily your Manta has been equipped with powerful lasers which don't need recharging and can make short work of a fighter craft — if you're quick enough to catch it that is.

A shrill siren lets you know when an attack wave is imminent, but you never know whether this attack is coming from the front or if it's going to be a crafty assault from behind. Whichever it is, you must keep your wits about you and remain cool at all times. Bonus points are awarded for destroying a complete wave of fighters.

As well as the fighters zooming in to attack there is an added danger: the Dreadnaught hulls are a veritable obstacle course sprouting ariels, flanges and ducts. Sometimes sheer walls of metal rise up to meet you as you pilot

your Manta at great speed — these can be identified by the shadows they cast on the hull. If your Manta crashes into an obstacle it is destroyed, and one of your three lives is lost. Some hull features can also be shot, adding to the amount of destruction inflicted on the huge mother ship.

Homing mines present another problem. Automatic launchers are activated when your Manta flies over them, and when they turn red they release a mine which chases your craft. A lot of quick evasive manoeuvring is called for to escape a mine.

To avoid some of the obstacles on the hull you must fly at right angles and squeeze through some tight gaps. Holding down fire and moving up or down flips the Manta sideways and slowing down brings the Manta back to its normal aspect. If you slow down and

CRITICISM

"I can't really say that I was looking forward to seeing this on the Spectrum as so many games C64 games die when they're converted for our faithful Sinclair. Thankfully there is still plenty of life in Uridium ZX — admittedly it has lost its colour and some of its sound but it's one of the best shoot em ups around. The speed at which the game plays is truly amazing, the screen scrolls at a tremendous rate and nothing slows down when a load of nasties come on the screen. The graphics are excellent, and everything is superbly drawn. The sound too is top hole: the tune on the title screen is marvellous and there are some worthy sound effects during the game. If you are a shoot em up freak then go out and buy this, you're not going to see better for a long while."

attack waves for you to deal with — if you like you can play the two player option with a fellow pilot and race to save the universe...

CRITICISM

"I really didn't expect Uridium to be up to the standards of the Commodore version, and it isn't — but it is an extremely good, fast translation. The graphics are very well done, but the monochromatic display can make it difficult to see the action. The scrolling is very fast and smooth, but I found that the Manta took quite a long time to respond when turning around. The sound consists of a good title tune and decent spot effects during the game. Overall, a first rate shoot em up."

CRITICISM

"Wowee! This game is absolutely mega. I don't care how well it compares to the Commodore version, because it's probably the best shoot em up that I've ever seen on a Spectrum. The graphics are brilliant, with some excellent scrolling, which of course isn't up to the standard of the 64 version, but it is quite stunning for the Spectrum. The title tune is very good, and the game moves at a frantic pace, often resulting in cries of 'What hit me?' and 'It missed!', but this is all jolly good, destructive fun, and that's what I like about it."

stop, the Manta loops and rolls to face in the other direction — a useful evasive manoeuvre. Looping also lifts the craft momentarily higher off the surface of the Dreadnaught, which might help to avoid an enemy fighter or an obstacle.

After your Manta has been in flight for a while the words 'Land Now' flash up at the top of the screen, accompanied by another siren. You now have to fly your Manta to the end of the Dreadnaught where there is a landing strip. Once you have set your craft down neatly on this landing strip, you automatically progress to the next Dreadnaught where the fun starts all over again.

There are fifteen Dreadnaughts to destroy. Each one has a different layout, more features and more

COMMENTS

Control keys: Left Z, Right X, Up L, Down SYMBOL SHIFT, FIRE ENTER, Pause P
Joystick: Kempston
Keyboard play: joystick is easier

Use of colour: mainly monochromatic

Graphics: very neat fast scrolling

Sound: really exciting and useful spot effects plus a tune at the beginning

Skill levels: one

Screens: scrolling play area

General rating: A very worthy version of a fast-moving shoot em up.

Use of computer	89%
Graphics	89%
Playability	90%
Getting started	89%
Addictive qualities	90%
Value for money	88%
Overall	90%

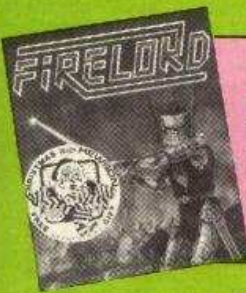
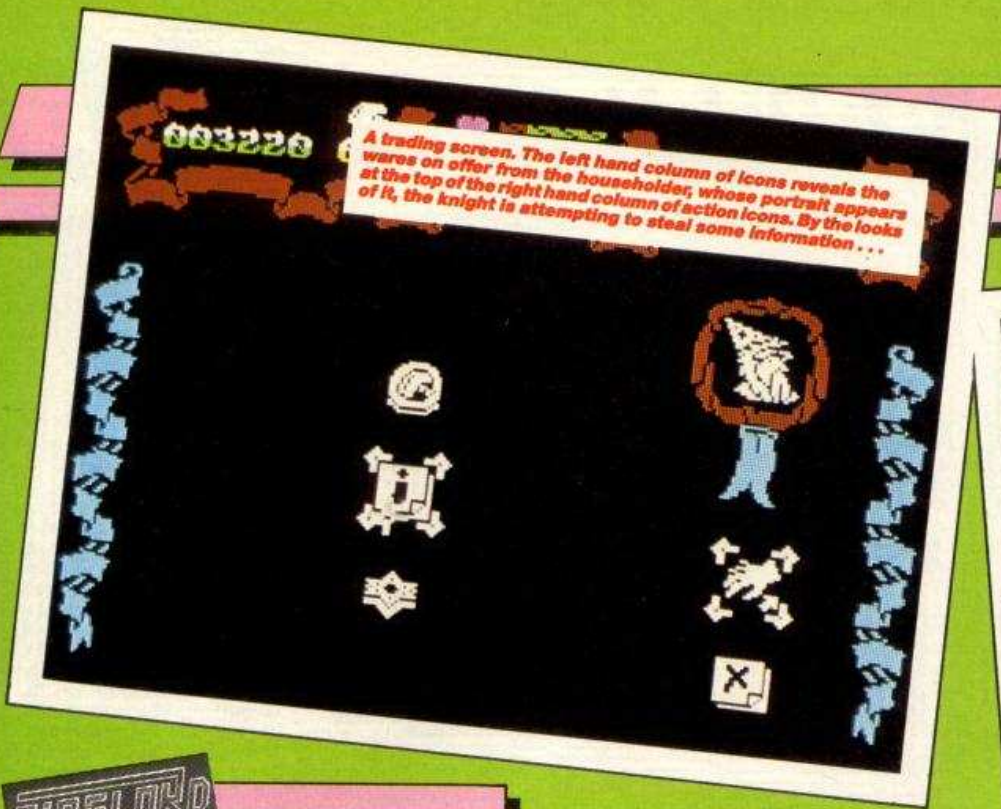

Producer: Hewson
Retail Price: £8.95
Author: Steve Crow



F·I·R·E·L·O·R·D



The trial screen. The blue arrows flash in rotation and to escape the rap you'd better stop them against the innocent verdict!



When Sir Knight enters a house, the view moves to an icon screen. One column of icons shows the objects which the housekeeper has to offer, another shows items carried by our hero. After deciding whether he wants anything, the hero can access a column of action icons and attempt to trade. If all else fails, a bit of pilfering might just work... The hands icon represents the theft option, and to steal you have to wait until the householder turns away and then move the control arrow from the theft icon to the object which you want to steal. Move it quickly to the object you are offering then

CRITICISM

"An excellent game this, but would you expect anything less from the man who brought us Star Quake? I really enjoyed playing this one although the instructions are not much help. I think Firelord will have wide appeal as you don't need a great deal of joystick mangling. A good memory is necessary however, as running around the hundreds of screens can often lead you to lose your bearings, and the signpost 'service' given by some home occupants isn't very helpful. Graphically the game is excellent, but its outstanding feature is the colour. The sound is admirable: there are a couple of tunes on the title screens and there are lots of lovely effects during the game. I strongly recommend this game."

CRITICISM

"I'm very impressed with this. I got straight into Firelord and thoroughly enjoyed playing it. The layout is very similar to Robin of the Woods, and graphically they are very alike. This is one of the best arcade adventures around. The sound is very good and contains some excellent spot effects and a good tune at the beginning. All the backgrounds are very colourful and are well drawn. I liked the way you can go into different doors and find different people in houses—all offering useful bits 'n' bobs. Stealing is also fun but quite tricky. Presentation is well up to Steve Crow's standards."

doesn't have any weapons with which to defend himself against the ghosts, so his first priority is to arm himself. His firepower comes in the form of different coloured crystals, but these only last for a while, so new ones must be collected.

Sir Galaheart roams around the land of Torot looking for the charms needed to brew the secret youth spell. Useful objects, spells and charms are kept by the inhabitants of Torot inside their houses, so Sir G. must enter their homes and barter with them. Some of the objects lying around in the open are useful when it comes to bartering with the locals.

CRITICISM

"Steve Crow has certainly got a fair list of hits behind him, from the very good Factory Breakout, to the superb Starquake. This next one follows on very well, though in a different vein. Another arcade adventure is all very well, but one of this calibre is very welcome indeed. The graphics are very good, with the colour used lavishly and to good effect. I don't think that there is anything in the game that is bad, in fact I like it a lot. If arcade adventures are your scene, then get a load of this."

Steve Crow has joined the HEWSON label for his latest release, having built up a powerful reputation as a Spectrum programmer with games like Wizard's Lair and Starquake. His latest game stars a chivalric hero on a quest to liberate an oppressed land...

The Evil Queen who rules over the stricken land of Torot has a new and very deadly weapon in her possession. Using her cunning charm she has tricked a dragon into parting with the powerful Firestone which conveys the ability to hurl fireballs. With this weapon in her hands the wicked queen sets about terrorising the inhabitants of Torot.

Luckily it just so happens that a happy avenger of evil is in the neighbourhood at the moment. Sir Galaheart is a fearless Knight who hopes to con the Queen into letting him have the Firestone. The wicked Queen is terribly vain and terribly scared of growing old and losing her beauty. Sir Galaheart plans to find the four ingredients for the spell of Eternal Youth and trade them with the Queen for the Firestone.

Although the inhabitants of Torot have fled into their homes, the land is by no means empty. Deadly Fire Ghosts abound, ready to sap away Sir Galaheart's essential life force if they get too close. When the bold knight's energy level reaches zero he loses one of his five lives. At the beginning of the game, Sir G.

the game. If Sir G wants to return to a Magic Place, he must remember the correct objects for the spell—casting the spell takes him to his destination.

Apart from useful objects, the knight can trade for information with the locals. Although they would like the reign of the power-crazed Queen to end just as much as he does, they'll only oblige for a price!

COMMENTS

Control keys: redefinable: up, down, left, right, fire
Joystick: Kempston, Cursor, Interface 2
Keyboard play: no problems
Use of colour: excellent
Graphics: picturesque
Sound: small tune on the beginning of the game with really good spot effects throughout
Skill levels: one
Screens: 500
General rating: Steve Crow does it again!

Use of computer	91%
Graphics	91%
Playability	91%
Getting started	85%
Addictive qualities	91%
Value for money	89%
Overall	91%

over to the acceptance icon and you have stolen the required object.

If the householder looks round at any time during the theft, you are automatically brought up before the Reeve, who judges you. Should he decide you're guilty you get a reaction test, and have three attempts at stopping a moving arrow. Get it wrong, and you could lose up to three lives.

Sir Galaheart has to keep his energy up, and tasty bits of food can be found along the way. When Sir G. picks these up, his energy level shoots back up to maximum. However, should the knight lose a life, he is instantly vaporised and his tin helmet clatters to the ground...

Your knight must negotiate his way through leafy glades and deserted towns in his quest. Apart from scuttling around on his feet, there are also transporters which take him to a different location in

MASTHEAD

Games

- (A) Spectrum 48K
- (B) CBM 64/128
- (C) Amstrad
- (D) C16 plus 4
- (E) Atari
- (F) BBC
- (G) Electron
- (H) MSX

Not For

Unbelievable Ultimate

Jetpac
Tranzam (A)

Lunar Jetman
Pssst

Atic Atac
Sabre Wolf (A)

Underwurde
Alien 8

Entombed
Blackwych (B)

Staff of Kanarth
Imotep

Sabre Wolf
Alien 8
Nightshades
© £7.99

Jetpac
Nightshades (F)

Knightlore
Sabre Wulf

Alien 8
Gunfright (H)

Knightlore
Nightshades

Arcade Classics

Pac Man
Dug Dug (B)

Mr. Do!
Pole Position

Pac Man
Dug Dug (E)

Mr. Do!
Pole Position

War Game Greats

Tigers in the Snow
Germany 1985 (B)

Combat Leader
Knights of the Desert

Big names Bonanza

Fight Night
Stellar 7 (B)

Forbidden Forest
Talladega

Krazy Kids

Kermit
Donald Duck (B)

Return to Oz
Congo Bongo

All cassettes **£9.99** (Except Unbelievable Ultimate Amstrad £7.99)

At a time when you're being showered with cut price bargains, amazing value packs or stunning compilations (of games you've never heard of?), then it's hard to work out what is a good buy and what isn't. Cast off the confusion and look no more, for here we present a range of compilations of games that are classics in their own right, or have established pedigrees which guarantee their quality. Here we have compiled a series of products which stand as the master of any of its rivals.

High Quality Compilations

Shoot 'Em Ups

Super Zaxxon
Dropzone (B)(E)
Blue Max 2001
Fort Apocalypse

Amstrad Academy

Zorro
Bruce Lee (C)
Dambusters
Bounty Bob

Spectrum Strikers

Bruce Lee
Zorro (A)
Pole Position
Cyberun

Scott Adams Scoops

Voodoo Castle
Strange Odyssey (A)(B)(C)(D)
Buckaroo Bonzai
Pirate Adventure *

Voodoo Castle
Strange Odyssey (E)(F)(G)(H)
Buckaroo Bonzai
Pirate Adventure *

Broderbund Blasters

Karateka
Steath (B)
Choplifter
Spellunker

Atari Aces

Zorro
Up n Down (E)
Spy Hunter
Tapper

Platform Perfection

Zorro
Bruce Lee (E)
Bounty Bob
Ghostchaser

Zorro
Bruce Lee (B)
Bounty Bob
Ghostchaser

* (Previously unreleased)

JUDGE DREDD

Mega City 1 lives on the edge of disaster. Only the constant vigilance of its Judges can hold back the wave of crime which threatens to engulf and destroy the city.
You are the law!

C64 £9.95
SPECTRUM £8.95



**YOU'RE NEXT
PUNK!**

from
MELBOURNE HOUSE
The Home of the Hits!



XENO

Producer: A 'n' F
Retail Price: £9.95
Author: Binary Design

The game of *Xeno* developed on the frozen moon of Io, where bored miners used to bash lumps of frozen methane around a flattened patch of ground. The computer version pits you against the computer or a friend. The screen shows a rostrum camera view of the pitch which flips between five overlapping sections, depending where the puck is. Each player controls one skimmer, and the idea is to knock the puck over the opposing players' goal line. The puck and the skimmers all float over the surface of the arena and bounce off each other and the sides of the pitch.

The players take it in turn to attempt to hit the puck. At the start of the game, a 'time out' is set and this time — from one to nine seconds — is the time a player has to set up a shot. When it's your turn, you position a cursor on the pitch. An 'elastic' line stretches between the skimmer and the cursor... useful, because the screen always displays the segment of pitch containing the puck, so if your skimmer is some distance away, it occupies another segment and doesn't appear on screen. Then, either when the time out ends, or when fire is pressed, the skimmer speeds towards the cursor. Then it's the other player's chance to have a go. Obviously, with longer time out times, both players can position the cursor meticulously, and have time to work out all the

angles. With quick time outs, it becomes a fast and furious game.

The idea is, predictably, to hit the puck through the opposing goal. When you do, the crowd roars, the electronic scoreboards around the stadium flash, and it's back to the centre for a kick off.

The game is divided up into four quarters which can last from one to nine minutes each. At the beginning of each quarter and after every goal, the puck is kicked off again from the centre. The pitch is shaped like a squared off oval, with goals placed at either end and the trick in the game is to try to keep the puck between you and your opponent's goal. Once it gets behind you, unless you can work out some fancy angles, it's best just to zip down to your own goal area.

There are no holds barred in this game, and in the true spirit of that ancient game soccer, it sometimes pays to play the man rather than the ball, as this can knock the opposing skimmer out of a favourable shooting position. This is particularly effective if you are the wrong side of the ball: if you can knock your opponent past the puck, he's going to find it difficult to score, giving you time to get back behind the puck.

After four quarters of frantic bouncing around, the winner is the player to score the most goals (match). There's no extra time if the scores are level...

CRITICISM

● "Wow! It's not that often that we get future sport simulations in, but when we do they are often

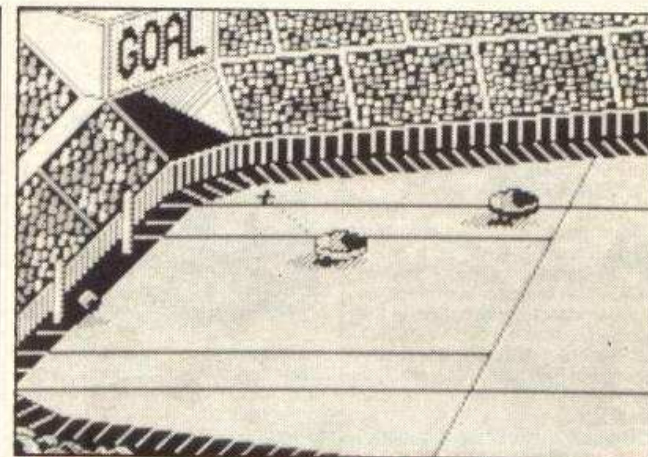

White puts the ball in the back of the net, after a clean breakaway which has left black stranded up the other end of the pitch

excellent. *Xeno* is the best yet. From the word go there is nothing but fast and furious action — the two skimmers whizz around the arena at tremendous speed and you really need to have your wits about you if you want to win. The game is extremely compelling to play and, due to its simplicity, very easy to get into. The graphics are very good, if a little sparse, and the characters are all excellently drawn, shaded and animated. The sound is not bad with stacks of spot effects during the game as well as a sort of tune thing. On the whole I strongly recommend this game — it is exceptionally playable."

● "Xeno is a strange but excellent

game. The game plays and looks like *Ballblazer* from above, but all the action is very smooth. I found *Xeno* quite hard to get used to at first, but after a few goes the basic idea of the game becomes very clear — move fast, and think even faster. Every move in the game has to be planned well in advance, as taking time to figure things out gives your opponent valuable seconds. The flick screen technique is well used. All in all *Xeno* is a very playable and addictive game."

● "Ballblazer was the only thing I could think of when I first loaded this *Xeno*, but after a bit of serious play, I decided that it was an excellent game in its own right. The graphics move smoothly and quickly, and the game bounces about at a rate which makes it both fun to play and addictive. The crowd around the stadium are a pretty well behaved bunch: no riots or anything in the future! Generally, I think that *Xeno* is the sort of game that I could play for an indefinite length of time: great!!"

As white attacks black's goal mouth, black decides to try a delicate deflection shot to save the day

COMMENTS

Control keys: redefinable: left, right, up, down, fire

Joystick: Kempston, Cursor, Interface 2

Keyboard play: joystick play is better

Use of colour: monochrome play area

Graphics: good shadows, smooth animation

Sound: you hardly get time to listen to it!

Skill levels: one

Screens: segmented pitch

General rating: A Fast and furious 'futuresport': well worth a look

Use of computer	85%
Graphics	83%
Playability	87%
Getting started	86%
Addictive qualities	88%
Value for money	84%
Overall	86%

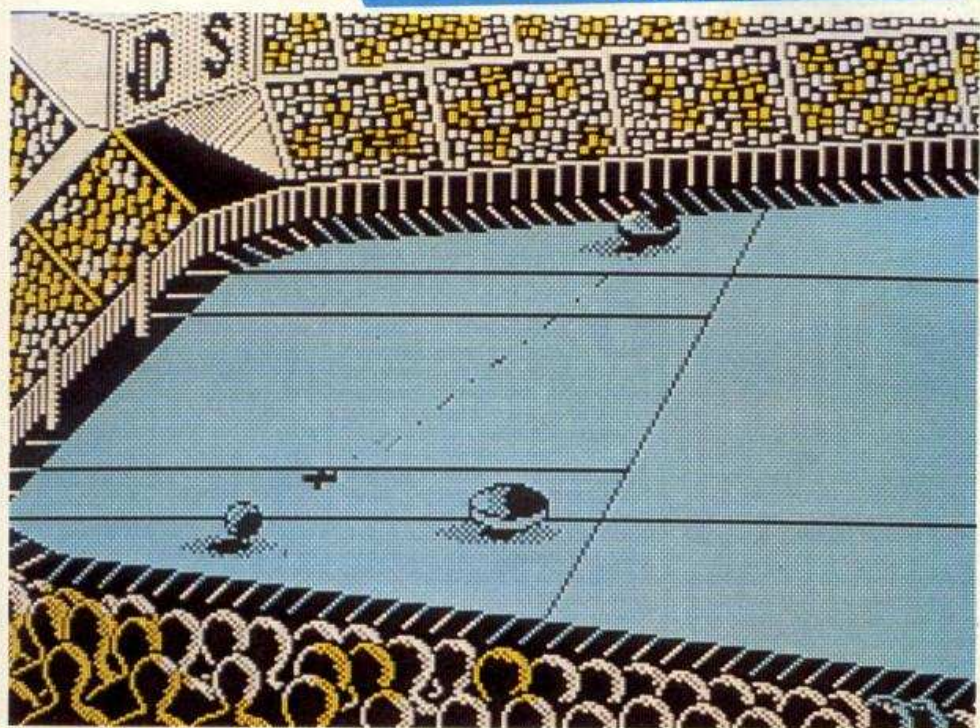

CITY SLICKER

Producer: Hewson
Retail Price: £8.95
Author: Steve Marsden and David Cooke

Authors of *Technician Ted*, David Cooke and Steve Marsden have just finished working on their latest project, an arcade adventure about life in the capital of Britain. Abru Cadabba decides to plant a bomb in the Houses of Parliament and emulate the action of Mr Fawkes all those years ago.

The game starts with the time-clock set at eight in the morning. The bomb is primed to go off at midnight so Slick only has a limited amount of time to get to the Houses of Parliament and defuse it. To do this he must find the parts of his Bomb Disposal Unit. When Slick finds a bit of the B.D.U he must scamper back to his hide out underneath the houses of Parliament and deposit the part there. Apart from the pieces of B.D.U there are also various other useful objects littered throughout the screens which Slick can collect and use to his advantage.

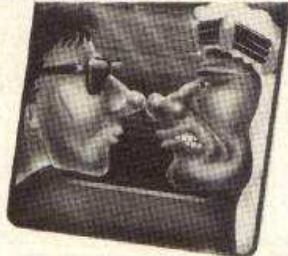

His energy can be restored by collecting various pieces of edibles which appear at intervals throughout the game. At the start of the game there are three pep pills at the bottom of the screen. If Slick's energy gets too low and there's no food in sight then he can take one of these pills to keep him going a bit longer.

Abru Cadabba is a very crafty terrorist and obviously very keen that his plot should go ahead without any interruptions. He also roams around the City persuading Slick and trying to catch him. If he succeeds in this then Slick dies and the bomb automatically detonates. An alarm sounds when Abru is about to enter the same screen as Slick.

One again, Cameron sits back and lets the demo mode get on with it down in the bloody tower

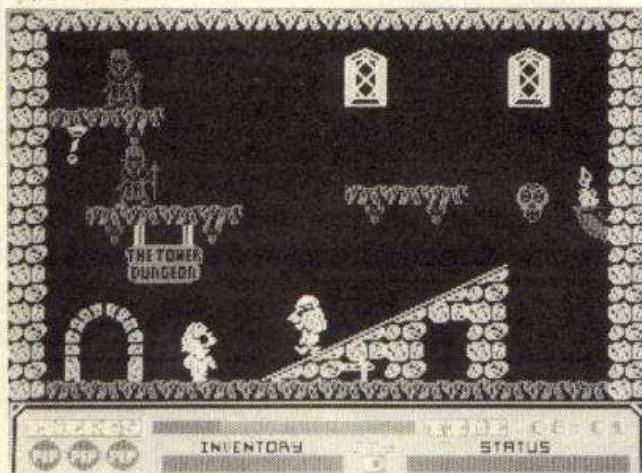

London certainly has some odd characters in it these days. From marauding Beekeepers to bottle lobbing Skin Heads, they're all there to hamper Slick in his mission. Each character has a different pattern in the game. They can open doors, throw objects, steal objects, follow Slick and generally hassle him every inch of the way. Every time Slick makes contact with a character in the game he loses some of his energy resulting in an inability to jump as high or as far as he could before. Some characters will even send him back to the start of the screen which he's currently exploring. Slick can also lose energy if he falls from a great height.

CRITICISM

● "I feel that Steve Marsden and company have really scraped out the barrel here. They haven't really changed their style since *Technician Ted* in early '85, which was slightly outdated then. Although there are some very nice touches in *City Slicker* the game as a whole is very similar to so many other games on the market that it is hard to appreciate this one. The graphics are very pretty, the characters are excellently detailed and animated and the

backgrounds are colourful but there is a bit of colour clash.

● "Oh my goodness, now even HEWSON has gone back into the platform arcade adventure days. Surely the public must be getting sick of this type of game, I sure am! That said, there no doubt that *City Slicker* certainly is a good game. The graphics are very smart and original. The movement of all the characters is a bit simple but good enough. Colour is well used throughout all the screens with no clashes at all. More of the Uridium stuff would go down better here.

● "Oh dear. I'm not here. I'm busy. I'm anything except writing a *City Slicker* comment. Please, don't make me do it! Noooo! I've played and written about innumerable arcade adventures today. I'm well and truly sick of them. *City Slicker* is another big, boring typification of this sort of game. And therefore I don't like it much. After *Uridium* & *Firelord* I expected more from HEWSONS.

COMMENTS

Control keys: Left=Q,E,T,U,O
 Right=W,R,Y,I,P jump=CAPS
 SHIFT,Z,X,C,V,B,N,M,SPACE
 Pick up=H,J,K,L Drop=S,D,F,G
 Pause=A Pause off=A again
 Sound=ENTER (toggle on/off)
 Reset=BREAK

Joystick: Kempston, Sinclair
Keyboard play: pretty good
Use of colour: pleasant
Graphics: well defined and nicely drawn
Sound: Amusing spot effects
Skill levels: one
Screens: half flip screens
General rating: not HEWSON's best

Use of computer	68%
Graphics	68%
Playability	66%
Getting started	72%
Addictive qualities	66%
Value for money	62%
Overall	65%

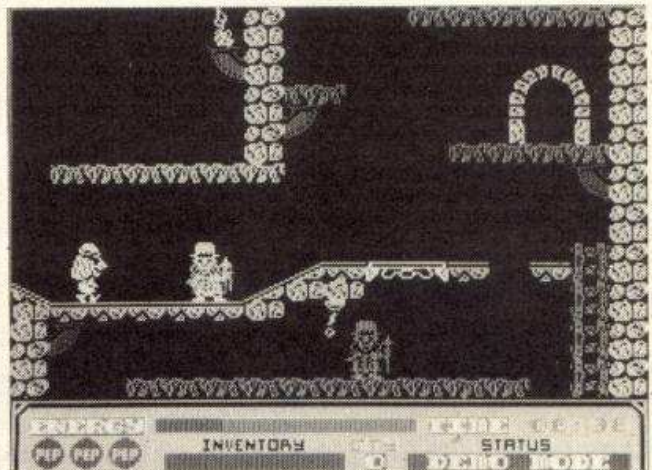

MIAMI VICE

Producer: Ocean
Retail Price: £7.95
Author: James Cornelius

Once again those cool trendsetters, Crockett and Tubbs, try to find time in their hectic schedule for a spot of police work. Armed with revolvers and a shiny new lotus (no tacky Granada with a flashing beacon on top for these trans-Atlantic coppers), they set out to put the world to rights and clean up those mean and dirty streets. In fact Crockett and Tubbs don't seem to rough it at all and probably while away the time at stake-outs comparing their designer clothing.

Anyway, it looks like Crockett and Tubbs are going to actually have to get down to some real work. The ignominious Mr J., a gangland smuggler, is expecting another shipment of illegal sub-

stances any day now. This is no paltry shipment, it's street value is estimated at around one million dollars. Crockett and Tubbs must race around Miami and try to shatter the smuggling network while bringing the baddies to justice.

In order to put the squeeze on this network, you start at the bottom by intimidating the minions; those men who are so hard up they'll croak on the others for a paltry 10 dollars. If you manage to bribe the right information out of these guys you may be able to seek out the suppliers and hassle them until you work your way through the entire organisation and eventually break it.

Once you have picked up the car you can proceed to explore the town, keeping an eye open for any suspicious goings on. Control of the car takes some getting used to, the acceleration is very quick but the brakes are not quite so

enthusiastic. The inhabitants of Miami are predictably reckless on the road. They seem to have absolutely no regard for anyone else and persistently drive their cars into yours, even though they must be able to see you coming. When this happens a large amount of Crockett and Tubb's energy is lost. Walls are not very friendly either, and if you hit them or stray off the road onto the grass verge, then your car goes "puff" and some more energy is lost.

Because the city is full of buildings, the ones where you're most likely to interrupt a meeting between the crooks are named. If you want to explore one of these meetings then stop the car outside, press fire and push left on the joystick. You are now free to roam around inside. Timing is quite essential in this game, as you should only visit one of these buildings while a meeting is in progress. If you're too early then the crooks will see your car outside and scarp. If you're too late then they will have gone.

of the games world - no, that's a bit strong . . ."

● "My goodness. *OCEAN* haven't half turned out a load of unplayable twaddle here. *Miami Vice* must be one of the most unplayable games of the year. The way that you control your car is ludicrous and takes at least half an hour to get used to. The stage where you look for the baddies is not done very well at all. *Miami Vice* just doesn't contain enough to be called addictive - bad try *OCEAN*."

● "I thought that the Zzap team were being unduly harsh on *Miami Vice*, however, after seeing it on the Spectrum I could only laugh. If you liked the series, then don't play this game as it may put you off it forever. The game is exceedingly annoying to play as your car is very difficult to control. The graphics are dodgy and the backgrounds are drab. The sound is also useless, there are no tunes and effects are rarely used. On the whole I haven't seen a game as dire as this in a long time."

The designer duo go crusin' for trouble down on the waterfront

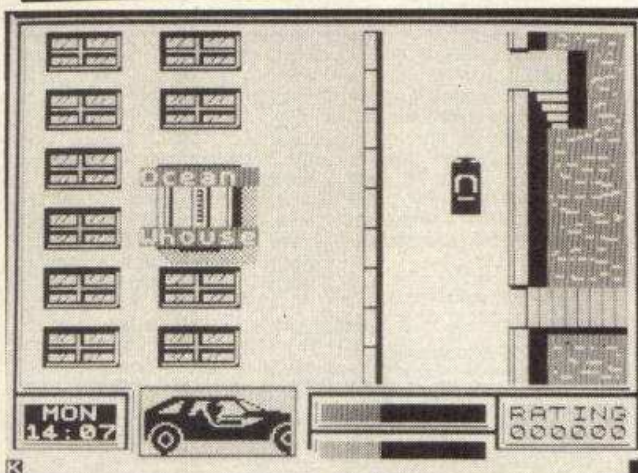

When a crook is captured you must take him to City Hall where he is interrogated. If the interrogation is successful then you will earn lots of extras points.

The game is over when Crockett and Tubbs capture the crooks and successfully bust Mr J.'s network.

CRITICISM

● "I don't ever watch the TV series so I can't compare the two, but if they are similar, then *Central TV* can't be doing very well. This game is bad. The graphics of the cars are totally unrealistic (unless cars have started altering dimensions while they turn corners, that is). The game is very quiet, but the background scenes are reasonable; they contain lots of colour, and are nice to look at; exactly the opposite of the rest of the game. *Miami Vice* is the Skoda

COMMENTS

Control keys: X=left, C=right, M=down, L=up, Y-P=fire, CAPS=pause, CAPS and E=abort
Joystick: Kempston, Interface II, Cursor
Keyboard play: spongy
Use of colour: dire, particularly on interiors
Graphics: basic
Sound: spot effects
Skill levels: one
Screens: scrolling play area
General rating: steer clear, take my advice

Use of computer	35%
Graphics	43%
Playability	24%
Getting started	30%
Addictive qualities	25%
Value for money	21%
Overall	27%

THE LEGEND OF APACHE GOLD

by Peter Torrance

Lonesome Cowboy 'LUKE WARME', not a Dime to your name and only dreaming of riches. But there is a LEGEND. A legend of great riches in an Indian Burial ground.

The legend of . . . APACHE GOLD!

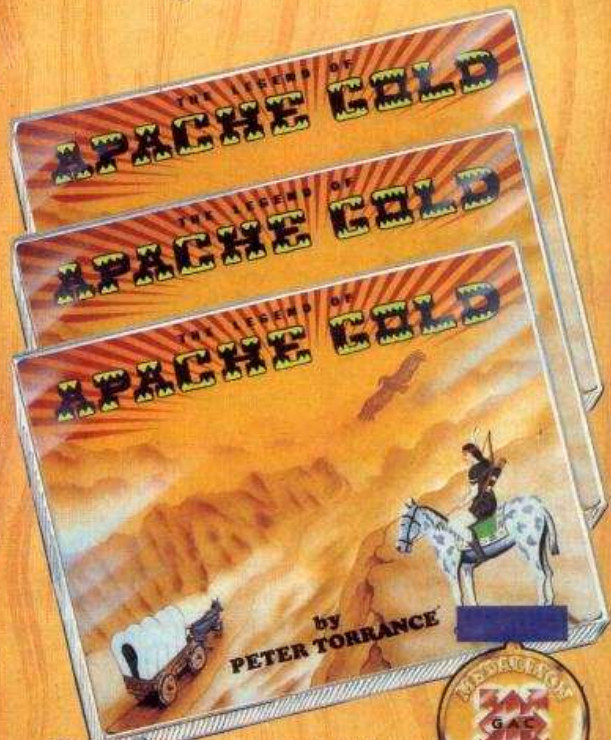

From the producers of THE GRAPHIC ADVENTURE CREATOR

Available from all leading retailers. Or direct from: INCENTIVE SOFTWARE LIMITED, 2 Minerva House, Calleva Park, Aldermaston, Berkshire RG7 4QW. Telephone: (07356) 77288.

PRIORITY ORDER FORM

Please rush me for my Spectrum Commodore 64 Amstrad CPC

Apache Gold £7.95 Winter Wonderland £7.95

Graphic Adventure Creator { Tape £22.95 Disc £27.95

I enclose cheque/PO or please debit my credit card

No _____

Name _____

Address _____

THE ICE TEMPLE

Producer: Bubble Bus Software
Retail Price: £7.95
Author: Tom Prosser

Nick has a very boring job. His only consolation is his car, a turbo-charged Space cruiser. All silver with spotless chrome dice etc. However, when Nick pops into his local newsagents, his beautiful space cruiser is stolen. Luckily for him it is fitted with an anti-theft device which enables him to track it down. He eventually discovers the ship on a distant asteroid well away from the usual spaceways.

Upon beaming down, he discovers that this is no ordinary asteroid - it harbours a very sinister secret. The asteroid's external disguise hides that fact that its interior is a vast Thermionic Reactor. The evil inhabitants of this planet are planning to turn everything in the Galaxy into an icy waste, starting here.

The Reactor runs on eight fuel elements, these are scattered around the whole asteroid. The only way to disable the Thermionic reactor is to collect all these elements and stick them down the Disposal units.

Before Nick can even contemplate embarking on this potentially lethal mission, he must first find his stolen ship. At the start of the game Nick is clad only in a skimpy little space suit, which makes him vulnerable to the marauding aliens. Some of these can kill Nick instantly, while others only sap away his body heat. Nick can shoot at these nasties, but

they soon re-form and take up the chase again.

Although this may sound like a hopeless situation for Nick, there are some objects on this mostly hostile asteroid which will help him. These are mostly different coloured ice crystals, with each different colour giving Nick a different power.

Once Nick has found his trusty space-cruiser he is virtually immune. The only way that the ship can be destroyed is if it runs out of fuel, so watch out for handy fuel packs. The main threat on this icy planet is the cold. Luckily there are radiation flasks, which, when picked up, will warm his icy blood.

Bombs come in several varieties; the magenta ones will kill all the aliens in the immediate proximity and the cyan bombs will blast away walls of ice. Magnetic clusters can be picked up and then used to distract the aliens, as these mechanical nasties will automatically be attracted by the cluster's magnetic qualities. When Nick is on foot he picks objects up by simply walking into them. When he is in his ship he has to get out and collect them.

Some of the passages on the asteroid are too small for Nick to fly through, so he must get out and explore these on foot. The game ends when all eight Reactor rods have been found and disposed of.

Nick has to dump the ship to get through a rather narrow gap

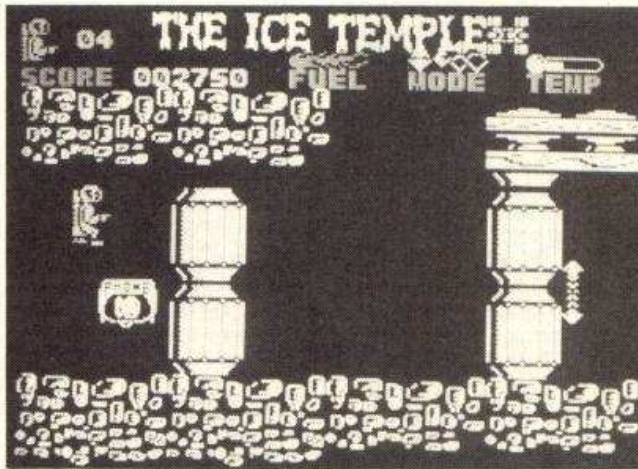

It's for you-hoo time for a quick teleport

CRITICISM

● "Ice Temple is well presented, with lots of options on the title screen and some nice sound effects, unfortunately it's not very original. The backgrounds are well drawn and add quite a bit of variation to a game which doesn't change much otherwise. I liked the 'kill on impact' baddies homing in and following you until you kill them, and the option to start where you died or in a different place altogether. Ice Temple is a pretty decent, if unspectacular game."

● "I thought that BUBBLE BUS had started the beginning of a long

decline after their last release, but it seems that they have seen the error of their ways. Ice Temple is a really good, well presented game, although it isn't quite up to the standards set by Wizard's Lair and Star Quake. The graphics are generally very good, the nasties are well drawn and the backgrounds are excellently detailed. On the whole, this isn't a bad game: recommended."

● "Moonlight Madness, BUBBLEBUS's last game, was an amazingly bad game. So the first time I saw Ice Temple, I thought 'here we go again'. After a short while, though, I started to play the game properly, and found out it wasn't all bad. The main character is poor, but the backgrounds and other sprites are quite satisfactory. As far as addictivity is concerned it's fair, but I can't help wondering whether it's really worth eight quid. Overall, while being far from one of my favourites, Ice Temple is not a bad game."

COMMENTS

Control keys: two set option ZXOKQ, QWERT plus the chance to redefine option one
Joystick: Kempston, Interface II, Cursor Joystick
Keyboard play: very good
Use of colour: lovely and colourful
Graphics: excellent effects let down by main character
Sound: tune at the beginning plus spot effects throughout
Skill levels: one
Screens: 800
General rating: not a bad effort

Use of computer	75%
Graphics	76%
Playability	73%
Getting started	74%
Addictive qualities	75%
Value for money	72%
Overall	75%

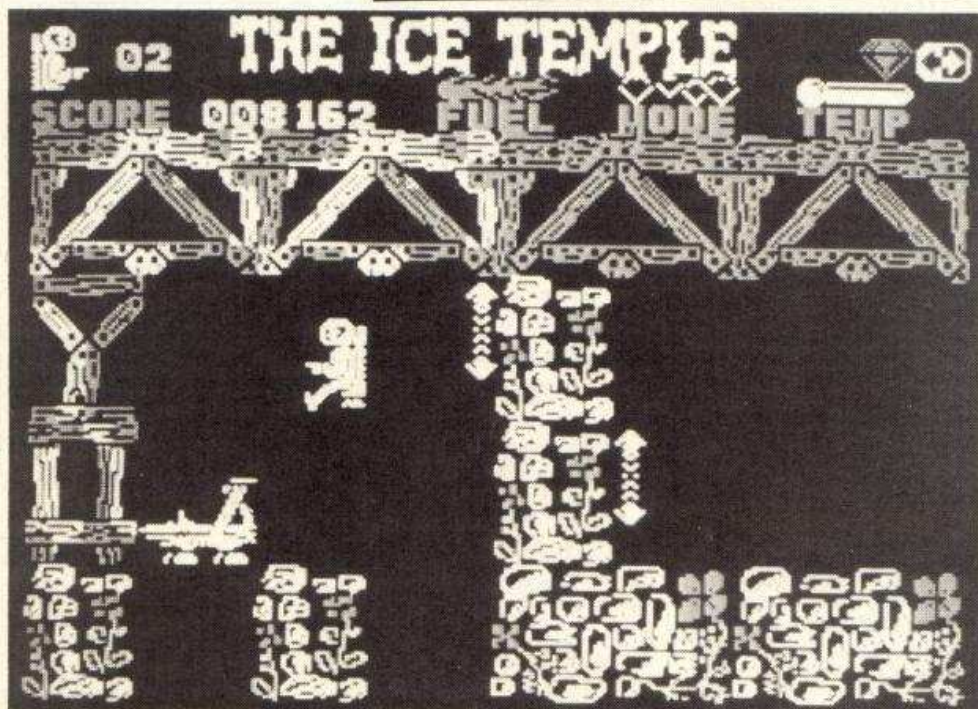

**A DEADLY ADVERSARY
...YOUR OWN MOTHERSHIP!**

Shadow Skimmer

It was a routine mission... to fly your skimmer craft around the hull of your Mark 47 Interstellar craft to check out its automated defense systems and robotic controls... don't they know it all malfunctioned?! Don't they realise the system has detected an alien it must destroy... ME!

A dazzling, supersmooth, super-fast space combat game featuring unbelievable full colour screens and pulse-racing action like you've never experienced before!

48/128 Spectrum £7.95



"Nothing comes close"

The Edge, 36/38 Southampton Street, London WC2E 7HE.

The best selling Computer Game is now available for the New Generation. Don't Get Mad - Get Even!



Full game or questions only available on Spectrum 48/128, CBM 64/128, BBC B,B+, Master, Amstrad CPC Cassette and Disk

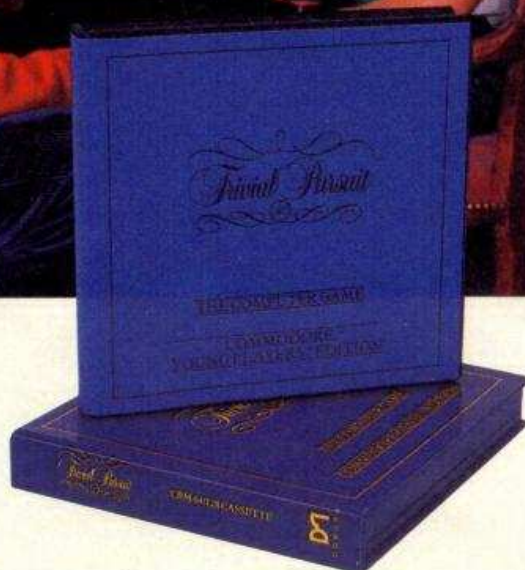

AWILSMITH TOPSOFT
20
John Menzies
and all local stockists



HORN ABBOT INTERNATIONAL

© 1988 HORN ABBOT INTERNATIONAL

YOUNG PLAYERS™ EDITION - OUT NOW

TRIVIAL PURSUIT is a Trade Mark owned and licensed by Horn Abbot International Ltd.
Published by Domark Limited, 204 Worple Road, London SW20 8PN. Tel: 01-947 5624.
Trivial Pursuit was programmed by Oxford Digital Enterprises.



DOMARK

ORBIX

THE TERRORBALL



Orbix is the codename for your tactical planetary warfare craft.

Spectrum 48/128
£7.95

STREETWISE SOFTWARE IS A DOMARK LTD LABEL
204 WORPLE ROAD, SW20, LONDON 01-947 5626

Streetwise

TERRA COGNITA

Producer: Codemasters
Retail Price: £1.99
Author: Stephen Curtis

The first batch of programs from a new company sees some old faces turning up. Stephen Curtis, author of the budget hit *Non Terraqueous* has forsaken MASTERTRONICS for this new outfit.

You play the part of some mining engineers trying to escape a rather unwelcoming planet in their scout ship. In this vertically scrolling shoot-em-up, you've got to shoot nasties, dodge obstacles and move over particular parts of the landscape to pick up lives and bonuses.

The landscape consists of squares which fall into a number of varieties. There are obstacles, to be avoided at all costs. There are fuel squares. Fuel is used up fairly

shoot 'em up and on the other it's an infuriating piece of budget software that I can't play. There is nothing at all revolutionary here but it has all been put together in a very professional way. Graphically *Terra Cognita* is not wholly impressive but the screen scrolls well and the characters, although being small, are nicely drawn. The sound is a bit disappointing as there are no tunes but the spot effects aren't bad. All in all this is well worth two quid."

● "The scrolling play area is smooth, but it is very hard to differentiate between what is coming up on the ground, as it is all the same colour and shape. I found the game very hard to play at first but once you've got the play area mapped out you have got no more problems, as it is just a case of remember and avoid. I felt that I

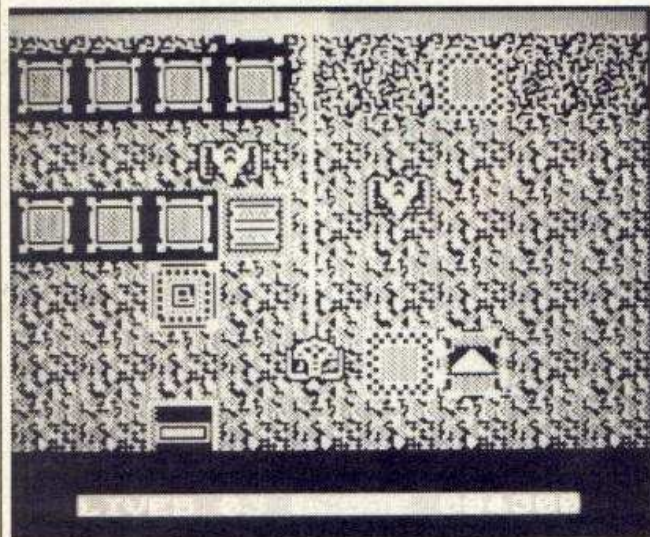

First section, look out for the walls and meanies coming up

rapidly, so unless you pass over such squares fairly regularly, the ship will fall out of the sky. Some squares will briefly increase your speed, whilst others will slow you down - these are vital to get round some of the more tortuous mazes.

There are bonus squares, extra life squares, and force field squares which make the ship invincible for a short time. Time shift squares are to be avoided, as these stick you straight back at the beginning of the game, although you do keep your score. All this and lots of blasting too!

CRITICISM

● "I'm in two minds about this game, on the one hand it's a very playable pattern game come

could have done with a few more lives as they didn't seem to be scattered about the planet in the most accessible of places. *Terra Cognita* is quite decent as shoot 'em up or avoid 'ems go, but as a game there isn't much to it."

● "A nice little shoot 'em up. If it were more expensive, then I would give it a bit of a murdering, but at this price, it makes a pretty little hour waster. I don't think its got much lastability; I don't think that its going to be playable for more than a day, but that, in my opinion justifies the price. The graphics aren't amazing, and the constant colour changing gets sore on the eyes sometimes, but the game is quite playable, and has echoes of that 'one more quick go' feeling about it."

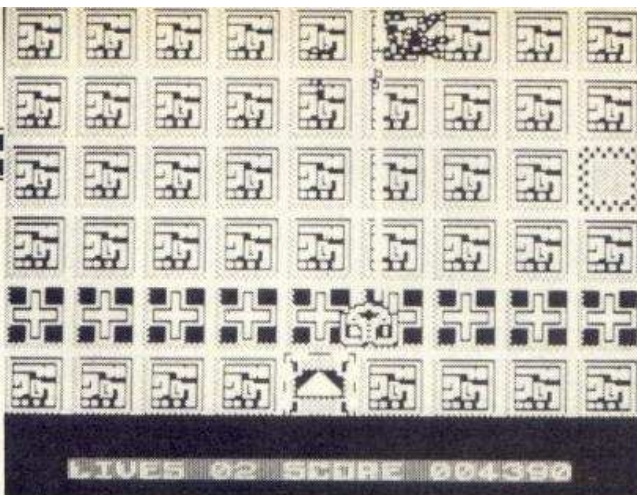

A meanie blasted just as you enter a high speed section

COMMENTS

Control keys: Redefinable; left, right, forward, back, fire
Joystick: Kempston, Sinclair, Cursor, Protek
Keyboard play: not a good idea
Use of colour: minimal
Graphics: fast with some detail
Sound: rather dull

Skill levels: one
Screens: 100
General rating: an addictive blast

Use of computer	72%
Graphics	73%
Playability	68%
Getting started	68%
Addictive qualities	70%
Value for money	72%
Overall	71%

PHANTOMAS

Producer: Code Masters
Retail Price: £1.99
Author:

Phantomas' task in this game is to hunt out a millionaire's mansion and plunder to his heart's content. But before he can indulge in this financial fantasy he must face many dangers and, solve the odd riddle or two.

All of these weird and wonderful creatures must be avoided because they sap Phantomas' essential life energy. And as he only gets one life you must ensure that this energy doesn't go down to zero or the game will be prema-

turely ended. Phantomas' life force is indicated by a coloured bar at the bottom of the main screen.

There are 36 levers on the planet Earth-Gamma. Each of these levers must be triggered. These levers are scattered throughout the labyrinth and Phantomas must switch them by jumping into them. Most of the levers are protected by the moving nasties. Some of the other levers however, take some hunting for. Rides in helicopters and space rockets are just some of the ways Phantomas can be transported to these remote areas. Some of these locations are rigged with traps, like the huge rampaging boulder he meets after the

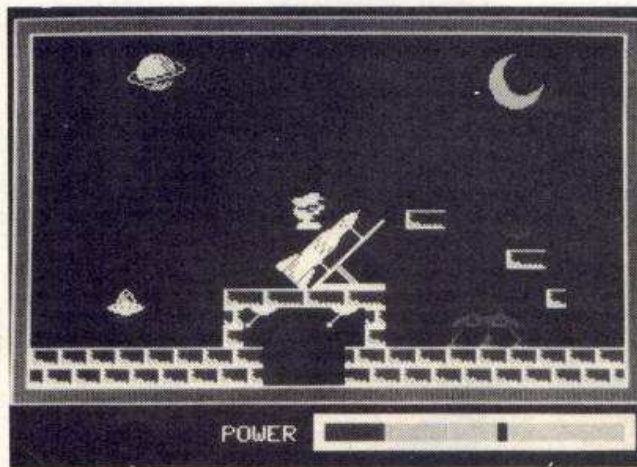

Off on the rocket; where to next?

BUDGET

helicopter ride. When Phantomas triggers this switch it releases a huge boulder which will crush the poor pilferer unless you're quick on those running keys and can get him successfully out of the screen. Once all 36 levers have been switched an alarm bell will sound and Phantomas will get a big strong box (presumably to carry his treasures in) and secret doors will open.

CRITICISM

● "Phantomas is lots of fun to play and quite addictive for a short while. It is very well presented and includes lots of well designed features; such as the tune at the beginning and all the little animated objects like the coat hangers and radar towers. Phantomas is very colourful and contains loads of little but detailed characters — the clouds are very good. Even though Phantomas is another in the massive group of arcade/adventures I found it a great little game."

● "Another Aardvark from CODE MASTERS and this time its a good one (horay!). Controlling your bloke can be a little confusing at first as there are two types of jump which are virtually identical. The graphics are small and undetailed but they are adequate. The sound on the other hand is very good, there is a lovely tune on the title screen and many admirable

effects during the game. This isn't at all a bad given the price: recommended."

● "Help! Not another platform game! I seem to have done almost nothing this month except review this sort of thing. And its getting to me. Phantomas isn't the worst of the lot though. The graphics are quite good, if very similar to its predecessors, and I enjoyed playing it to an extent. Platform games have never really appealed to me, but I think that Phantomas is a reasonable version on a far too old theme."

COMMENTS

Control keys: Definable
Joystick: Kempston, Interface II, Cursor
Keyboard play: Probably easier than joystick
Use of colour: rather jolly
Graphics: rather flickery in places
Sound: A really good un-Spectrumy tune at the beginning. Basic sound effects throughout
Skill levels: one
Screens: 80 separate rooms
General rating: indifferent little aardvark

Use of computer	66%
Graphics	66%
Playability	61%
Getting started	64%
Addictive qualities	62%
Value for money	70%
Overall	64%

OBLIVION

Producer: Alpha Omega
Retail Price: £1.99
Author: Simon Morris

Plot, ha! Who needs plot. Look, there's just no way you are going to stick any sort of plot together around a game like this.

Just look at the basic material. There is a robot ostrich running

along a wooden conveyer belt shooting things. Now naturally there are a few conceptual problems here. Why would anyone make a robot ostrich? O.K. so some nutter builds an ostrich. Just about the least likely thing he is going to do with it is give it a laser canon and put it on a hostile wooden conveyer belt.

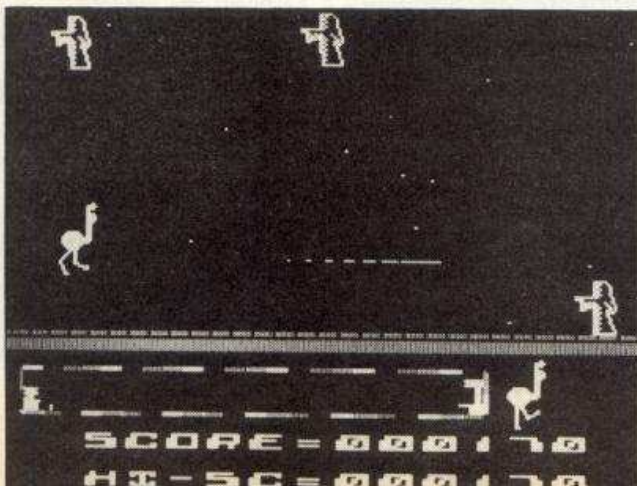

So what do you do? Well, our ostrich has to get past forty waves

What's this? The manic ostrich is blasting bods



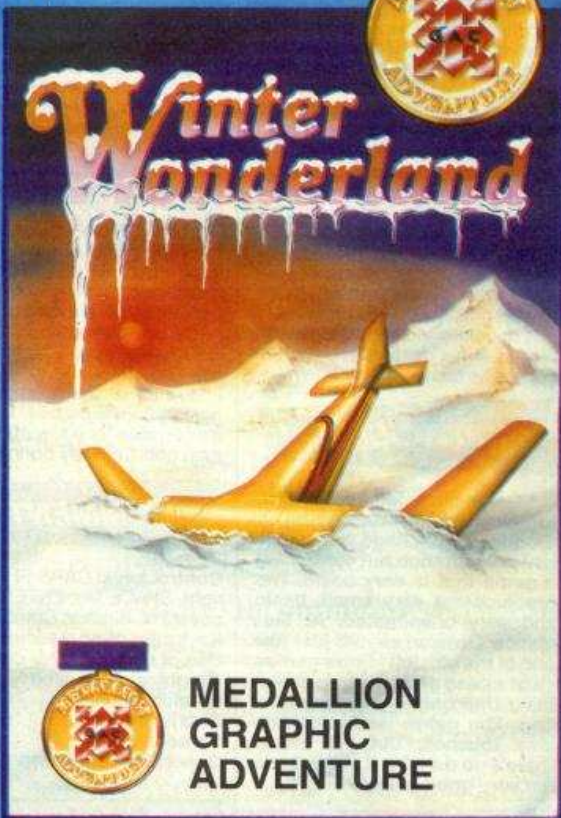

Winter Wonderland

MEDALLION GRAPHIC ADVENTURE

Breaking through the dense cloud cover you were relieved to see a dazzling white snowfield spread below you. Desperately preparing for a crash landing, you were distracted by a glint of sunlight on glass — a building! Could THIS be the lost civilisation?

Your attention however was drawn back to the ground hurtling towards you ...

From the producers of
THE GRAPHIC ADVENTURE CREATOR

AVAILABLE FROM ALL LEADING RETAILERS or direct from:
INCENTIVE SOFTWARE LTD.
 2 Minerva House, Calleva Park, Aldermaston, Berkshire RG7 4QW.
 Telephone: (07356) 77288.

MASTERCARD VISA **PRIORITY ORDER FORM** 

Please rush me for my: Commodore 64
 Spectrum BBC B Amstrad CPC

WINTER WONDERLAND £7.95
 Apache Gold (except BBC) £7.95

Graphic Adventure Creator { Tape £22.95
 Disc £27.95

I enclose cheque/PO or please accept my credit card No. _____
 Name _____
 Address _____

of aliens as it waddles along the belt. It can move left and right, jump and fire. The meanies move in different ways depending on the wave it's on. Such lethal doobries as aliens, rocks and ghosts come at our intrepid ostrich. But, fortunately, our mettalic hero represses his natural urge to bury his head in the sand, and blasts away. Trouble is, the laser only fires horizontally, and, as the laser is attached to his head, this means that anything at knee level is a bit of a poser.

Contact with any of the meanies results in the loss of one of your three lives. Some even fire back! It's just not fair. After forty waves of this mindless violence the ostrich arrives at his destination. Then of course he starts all over again.

CRITICISM

● "Come back Jeff Minter, all is forgiven. ALPHA OMEGA have again produced a package with excellent presentation but containing a game that is very basic. The graphics are very small, basic and very unanimated. At first glance *Oblivion* seems just like one of the old Jeff Minter games - just a case of blowing up everything that comes in your direction. The game features some nice touches, but I'm afraid there's no denying it, *Oblivion* is not very good at all."

● "Yeah! This is the sort of game that I can really relate to man. Mindless blasting may have gone out with flares but there is still plenty of fun to be had from it (and flares are coming back in anyway). ALPHA OMEGA haven't really raised any eyebrows in the trade (except

in disgust) but I think they may have hit the nail on the head here. The graphics are a little on the dull side, and soundwise there's nothing here that is new, except for a few well placed spot effects. I'm not too sure that I'll be playing this for long, but it'll certainly brighten up your afternoon."

● "Ha, ha, ha. An ALPHA OMEGA game. After the tremendous success of *Captain Slog*, and *Dekorating Blues*, I really expected a lot from this game. It gave me everything that I looked for; bad graphics, appalling sound, and a total lack of playability. No, not really. Like *Dekorating Blues*, there is a lot of effect on the title screen, but the game lacks somewhat. Like a lot of the average budget games on the market, I think that it's playable for a few minutes, but then gets infinitely boring."

COMMENTS

Control keys: CAPS SHIFT left, Z right, SPACE fire, ENTER jump.

Joystick: Sinclair, Cursor

Keyboard play: reasonable

Use of colour: rather drab

Graphics: uninspired

Sound: minimal

Skill levels: one

Screens: one

General rating: cheap and mindless

Use of computer	52%
Graphics	46%
Playability	52%
Getting started	56%
Addictive qualities	46%
Value for money	51%
Overall	45%

180

Producer: Mastertronic

Retail Price: £2.99

Author: Binary Design

Oneehundredaneighteeee, the bellicose amplified sound echoes around the smoke filled, beer laden tables of the local working man's club. And

on the stage, two lads with over-size guts working away at a spectrum.

All the fun of Britain's most popular indoor sport comes courtesy of those busy lads from the Binary Design team. Can you topple Jammy Jim, World Champion and ace darts player from his No. 1 slot?

After selecting the controls, you are presented with three different games: two player, one player, or practice. The practice game takes you 'round the clock'. The idea is

Oneehundred; can you be at old Del Boy

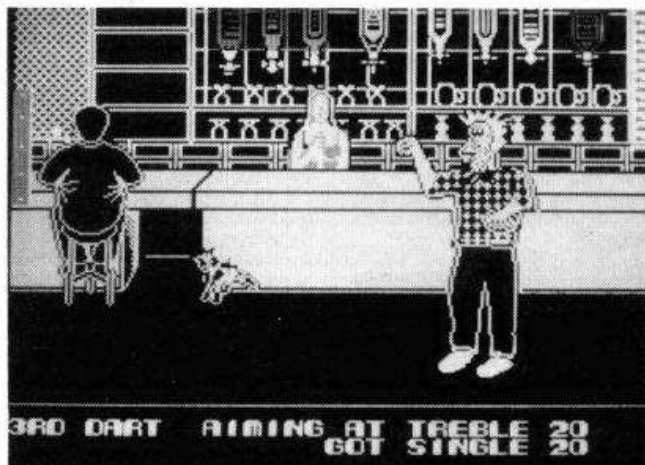

Lets have a look at the old scoreboard before the next level

to run down from twenty to one in one hundred seconds.

When it's your turn to throw, the screen shows a close up view of the dart board, and you control a large hand holding a dart. The hand moves in four directions diagonally across the board, moving in the direction it was last pushed in. You hit fire to throw the dart. The dart is also being 'waggled', so depending on the exact moment the dart was released, the trajectory will vary, and thus the final position on the board.

After three shots, the darts get handed to your opponent. If you're playing the computer, the display switches to a side view of the board, showing your good self propping up the bar whilst a bar maid recharges your glass and your opponent does his stuff with the darts.

You can play the main game against a friend, or the computer. You start at 501 and work down, double to finish. To beat the computer, you play three matches. The first two are the best of three against such stars of the silver arrows as Delboy Des, Devious Dave or Limp Wrist Larry. The final is against Jammy Jim. Trouble is, he throws perfect darts. Your only advantage is that you go first. This guy is very hard to beat, he finishes every game in nine darts! The game packaging also contains a very handy table giving you the best scores to aim at to go out.

believe me! 180 is a whole new different concept of darts computer playing. The graphics are superb — a brilliant combination of large detailed graphics and pleasing colours. The animation of the hand is extremely well done and the darts fly out of it very smoothly. The only thing I missed was the Northern accent of Sid Waddell commenting in the background. 180 must be definitely the best and most addictive darts game around."

● "The graphics on the throwing screen are excellent, but I think a little too much colour has been used on the opponent's throwing screen. Loads of featurettes have been put in, like the little dog who cocks his leg on the bar, and all sorts of things that make it really interesting to play. I would have liked to see a 'score required' indication, for non-mathematicians like myself, and I was a little disappointed to find that the finalist NEVER makes a mistake, but other than that, I think this is a Darts game that anyone is going to find it hard to match.

COMMENTS

Control keys: redefinable; left, right, up, down, throw

Joystick: Kempston, Sinclair, Cursor

Keyboard play: awkward

Use of colour: limited

Graphics: well detailed

Sound: unintelligible speech

Skill levels: one

Screens: two

General rating: best ever darts game

Use of computer	68%
Graphics	68%
Playability	70%
Getting started	75%
Addictive qualities	65%
Value for money	77%
Overall	72%

CRITICISM

● "There isn't really anything here that is done badly, it is presented in an average way both graphically and sonically, the game does get a bit boring after a short while due to the simplicity of the subject matter. On the whole this isn't a bad little game but I wouldn't recommend it as it gets monotonous after awhile."

● "Oh no not darts again, I hear you cry! But this is different —

VAMPIRE

Producer: Codemasters Software
Retail Price: £1.99
Author: Emilio Salgueiro

For many years now the Planet Earth and its surrounding space stations have been terrorised by Count Dracular. The appearance of this gothic character in the space age year of 2987 is strange enough for a start, but Dracular has not come alone. By chewing at the necks of earth's inhabitants, he has recruited his own army of vampires, these are in turn feeding off the people of Earth.

Armed with only a poem about Vampires to help him, our hero - Brok - sets off to tackle the vampires. His aim, to find the stake, the hammer and the cross which will dispatch the blood-lusting count and his nasty adversaries. The castle has two sections, there's the underground system of dungeons where it's dark and stuffy and, if he can get that far, the surface part of the game. The Count is a crafty devil and has been expecting such a visit. He has rigged the entire castle with all manner of strange traps to destroy the brave Brok.

Brok only has one life in the game and this is represented by an energy chart at the bottom of the screen. Brok's energy decreases every time he brushes against one of the Count's minions. When this chart reaches zero the game is over.

Brave Brok moves around the castle on his feet, although he does possess a very high leaping facility (and a not so high jumping facility) which can take him out of danger now and again.

Brok must find three keys as he toddles around the labyrinths. There are also certain objects which must be collected in order for Brok to progress through the game. And, finally, there are the three objects which will finish off the Count once and for all. Evil cackle.

is a very small bloke that trudges around in a very simple fashion. The things that he encounters in his quest range from some very simple one direction arrows, to well animated bubbles and fiery candlesticks. Vampire is a well presented game, but it is let down by flickery graphics and simple gameplay - but not a bad effort."

● "No sorry I've given up with this one, it's just too frustrating to play anymore. I was looking forward to it, as Code Masters other games aren't at all bad but this has certainly changed my view of them. I suppose it's not too bad. The graphics are fairly good and there is some colour clash but what do you expect for two quid? There are plenty of budget games around that are a lot more playable than this so I wouldn't really recommend it."

● "Aw no! Not another one! I'm going to sit in a corner and moan if companies keep on producing games of this style. Argh! I'll be forced to play aardvarks all day. Urgh! A word of warning to soft houses; I hate this sort of utterly boring, run of the mill, sub-standard, average game. Very sorry, Code masters, but I don't think that this game is very good at all. OK?"

COMMENTS

Control keys: Definable
Joystick: Kempston, Cursor, Interface II
Keyboard play: easy to confuse the two types of jump
Use of colour: fair
Graphics: adequate for a platform game
Sound: spooky little tune at the start of the game with some spot effects throughout
Skill levels: one
Screens: 80 different rooms
General rating: another slight variation on a rather tired theme

Use of computer	58%
Graphics	60%
Playability	46%
Getting started	49%
Addictive qualities	47%
Value for money	58%
Overall	51%

CRITICISM

● "Blimey! Another game from the CODE MASTERS, they must be working overtime! What we have here is another budget arcade adventure. The main character

An arrow comes wingin towards our hero!

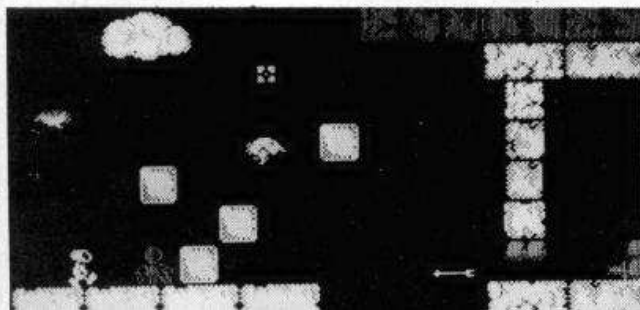

THE AWARD WINNING GRAPHIC ADVENTURE CREATOR



Will change the face of the adventure software market.
AMSTRAD ACTION

THE ANSWER TO YOUR PRAYERS!
C&VG

A very clever utility ...
very easy to use.
KEITH CAMPBELL, COMMODORE USER

Highly recommended.
ACORN USER

A very impressive and sophisticated adventure generator.
SINCLAIR USER

Now everyone can write professionally illustrated adventure games.

The Graphic Adventure Creator - THE adventure writing utility of the eighties.

* Unleash the Power of your imagination *



AVAILABLE AT ALL LEADING RETAILERS or direct from:
INCENTIVE SOFTWARE LTD.,
2 Minerva House,
Calleva Park,
Aldermaston,
Berkshire RG7 4QW.
Telephone: (07356) 77288.

PLEASE RUSH ME (1st Class Postage FREE)
THE GRAPHIC ADVENTURE CREATOR

Tape £22.95 Disc £27.95
Winter Wonderland graphic adventure £7.95
Apache Gold (Except BBC B) £7.95
The GAC Adventure Designer Pad £7.95
SPECTRUM COMMODORE 64 AMSTRAD CPC
BBC B GAC extra information - free with any order

I enclose Cheque/P.O. for £. _____
or please debit my credit card No. _____
Name _____
Address _____

CAMELOT WARRIORS

Producer: Ariolasoft
Retail Price: £8.95
Author: Victor Ruiz and Florentino Pertejo

There you are, all tucked up snugly in your comfy bed dreaming wonderful dreams. Tonight you're back in the days of King Arthur. You're a brave, dashing knight: rescuing beautiful damsels from distress and generally buckling your swash. But in the morning your alarm clock never rings and when you open your eyes you are no longer in your semi-detached in Surbiton, but, gadzooks in the very land of which ye were dreaming.

Gone are your street-cred clothes and your Diadora trainers and in their place is a splendid suit of armour. This might not look quite as cool as your previous attire but it will certainly equip you a lot better in this hostile world.

Armed with your trusty sword Excamembert, your task is to go forth and redress the balance of time. This is why, four twentieth century elements have followed you through the time warp. These elements must be found and given to a Guardian who will return them to their real time. These elements are the Fire Which Does Not Burn, the Mirror of Wisdom, the Elixir of Life and finally - The Voice From The OtherWorld (sinister chuckle).

There are four environments which you must cross before you can even contemplate returning to your own time. There's the forest, the lake, the caves and eventually

the castle where King Arthur is waiting to meet you. At the end of each of these sections is one of the vital elements which must be returned to 1986. Once each object has been collected it must be delivered to the Guardian and his magic cauldron.

Each section has different nasties, for instance the lake is full of killer eels and nasty fish, and that Guardian can do some very anti-social things to you, like turn you into a frog. This might seem a might unreasonable to begin with, but having this amphibious form will allow you to get through the lake section a lot easier than if you had a human body.

Did all the great and fearless men die out in the Middle Ages and are we all a bunch of wimps in the twentieth century. Only if you finish the game will you ever know!

CRITICISM

● "If you fancy a bit of a change then this could well be what you're looking for. There is an immense sense of playability from the word go. As I hacked away at the first couple of winged beasts and then started off on the quest toward Camelot Castle, I became totally engrossed. Each of the characters is excellently drawn and the backgrounds are colourful and well detailed. The sound is also quite good. I enjoyed playing Camelot Warriors, it was tre-

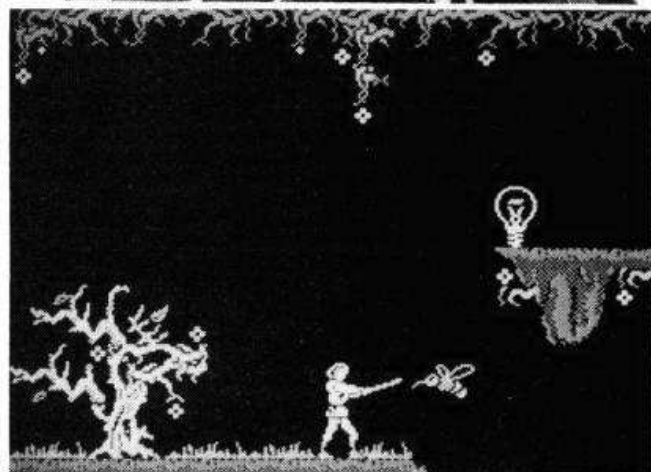
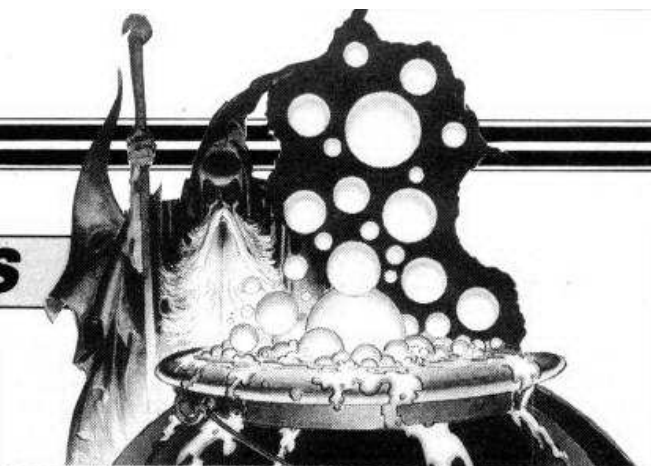

A medieval lightbulb? A slight anachronism methinks

mendously compelling."

● "Camelot Warriors is a pretty arcade adventure. I found the game relatively easy to get into, despite the blocky error detection and slow responses to joystick movement. Animation of all the characters is very well done; especially the owl which flies over the cauldron. The game contains very little colour clashes, but uses colour lavishly. The only annoying part of Camelot Warriors was that you can go so far in the game and then no further. I found the game a joy

to play, although at nine pounds I feel most people won't get far enough for their money."

● "Camelot Warriors is a very appealing game. I enjoyed playing it a lot. While some of ARIOLASOFT'S more recent products haven't been of the highest quality, I think that Camelot Warriors is the sort of game that they should be producing as standard. Colour has been used to excellent effect, and the graphics in most cases, are beautifully animated. Addictive and playable, this game is one that is well worth a quick play or two, but I doubt whether it fully justifies its price.

Our hero approaches the first wizard and disposes of another meanie



COMMENTS

Control keys: Q up, O left, P right, M Fire

Joystick: Kempston

Keyboard play: sensitive

Use of colour: pools of limpid colour in the evening light... alright!

Graphics: large sprites, well animated

Sound: a bit of Scarborough Fair to begin with and some spot effects throughout

Skill levels: one

Screens: about 70

General rating: An engaging but overpriced little romp

Use of computer	82%
Graphics	88%
Playability	83%
Getting started	83%
Addictive qualities	86%
Value for money	80%
Overall	82%

HYPABALL



Edin
COMPUTER GRAPHICS LTD



SALES 01-631 5206
01-379 6755
INTERNATIONAL 44-1-379 6755
COMMODORE 64/128: SPECTRUM 48/128K

COMMODORE 64
SPECTRUM 48K AND
ATARI 400 (48K MINIMUM)
130XE/800/800XL
FREE POSTER WITH EVERY COPY

SKY

RUNNER



...THE FIGHT HAS ONLY JUST BEGUN!
Human kind is under threat — from **SKY**

SKY — Narcotic. Patent and plentiful! The drug that keeps the future masses in a state of docile obedience.

SKY RUNNERS — Organised Ruthless. The agents who harvest, process, and distribute SKY.

RUNNER SQUAD — Elite mercenaries. Employed by a consortium of rebels, they must halt the SKY RUNNING in the only way they know how — total destruction.

AVAILABLE FROM ALL GOOD SOFTWARE
RETAILERS OR, IN CASE OF SUPPLY
DIFFICULTY, DIRECT FROM CASCADE
24-HR. ORDERLINE
(0423) 504663
CASSETTE: £9.95
DISK: £12.95



Cascade Games Ltd
Harrogate, HG1 5BG, England
TEL: (0423) 504663

Screen shots are taken from the © 84 version.

GOONIES

Producer: US Gold
Retail Price: £7.95

Real Estate agents move in on the Goonie's homes and offer a pay-up or move out alternative to the families living there. Not being terribly well off the households agree to sell up. However, on their last day in the house the Goonies (so named because they don't really fit in with other kids in the neighbourhood) discover some ancient pirate paraphernalia which indicates a substantial fortune of buried treasure so they decide to go off in search of One-Eyed Willy's Pirate ship, the general idea being that if they find it they can afford to buy their parent's homes, thus thwarting the plans of the greedy Real Estate sharks.

Like the film, team work is very much a feature in this game. The basic idea is that each screen contains a puzzle which two of the Goonies must solve. Each puzzle is different but the idea is always the same: to get both characters through a concealed exit out of the screen while at the same time avoiding whatever perils are lying in wait for them. It is impossible for any screen to be completed without the interaction of the two Goonies with each other. If you're playing with another person then each player controls one Goonie. However, the game can be played by one person on their own by changing the control of each Goonie by pressing the CAPS key.

Our two fearless adventurers flee in terror from the nasty old woman

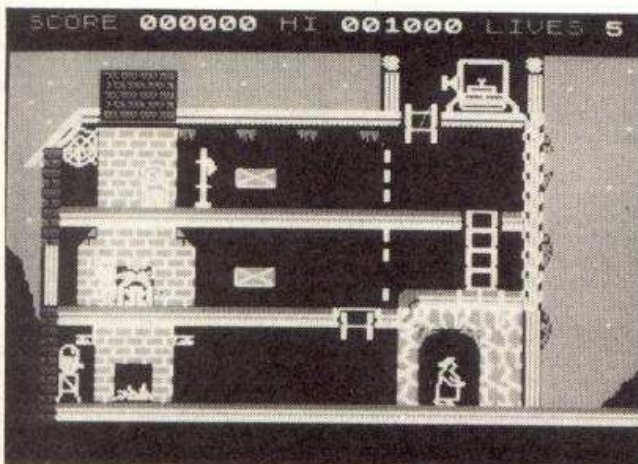

For the completion of each screen you are awarded 1000 points, but extra points can be scored for other actions that solve problems on screen, such as flipping a switch that opens up the secret exit. When both Goonies

are safely out of a screen you will automatically progress to the next one and so on until One-Eyed Willy's treasure has been found

Each screen contains all sorts of perils for each pair of Goonies. Manic butchers try and chop them up not to mention killers bats, vats

CRITICISM

● "Well US GOLD certainly took their time in releasing this one, the film's so old that even the backward Ludlow Regal has

at all. This is a definite case of see the film then buy the game."

● "I can't even say that I enjoyed the video. Loads of little kids screaming about an Indiana Jones scenario is the sort of thing that makes me sick. The game follows in the same vein. Graphics are awful, with some really dire anima-

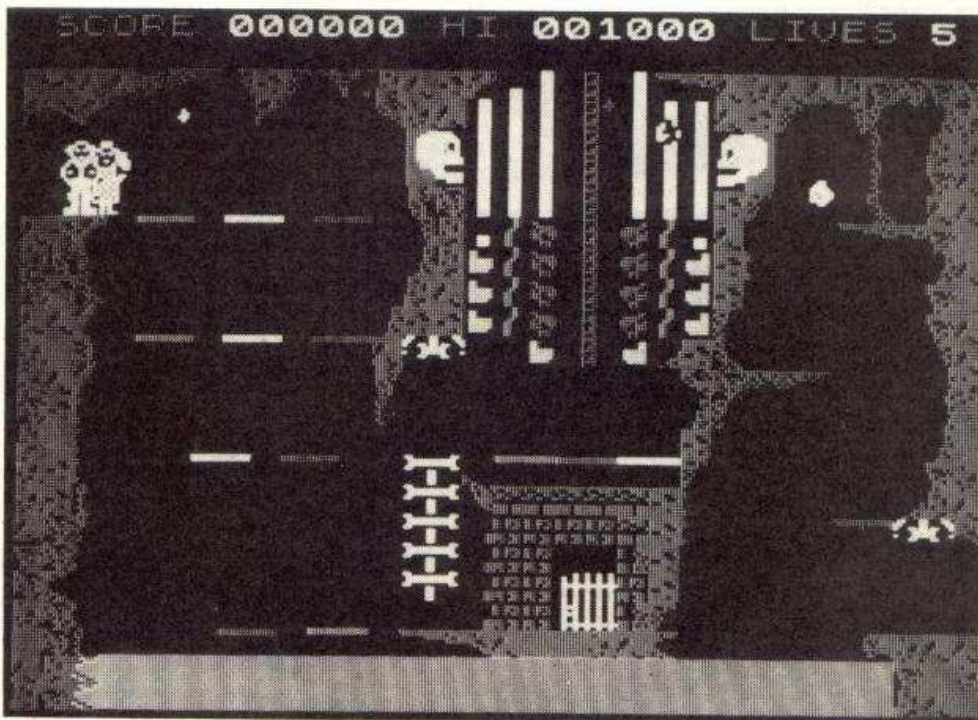

Cameron fearlessly uses demo mode to get to one of the later screens

shown it. The game is a little on the dull side, the puzzles are generally very easy so you can rush through the first few levels without much brain ache. The graphics are a bit tacky, the characters move about badly and they are badly drawn, the backgrounds however are a little prettier. I don't really think that *Goonies* represents very good value for money as there are many budget games around that are in the same vein."

● "I must confess, *Goonies* is much better than I expected. The graphics are well designed, if a little small, and each screen contains an effective amount of colour. Soundwise, *Goonies* is right on line, with good spot effects, and an in game tune that can be turned on and off. The tune didn't seem to slow down the fast gameplay at all. It is a definite teamplay game, and in two player mode lots of suggestions can fly around as to what the other person should be doing. The problems on each of the screens differ tremendously in difficulty, and you'd be doing well to get off the first screen in your first few goes — unless you've seen the film, then it won't take you any time

tion'; at least the kid can walk like an Egyptian! Playability wise, the game didn't grab me at all; if anything, it let me drop. The sound is the sort that gives Spectrum owners a bad name. So's the game."

COMMENTS

Control keys: SPACE=pause, Q=up, A=down, O=left, P=right, CAPS=fire/change control of character

Joystick: Kempston, Sinclair

Keyboard play: good

Use of colour: rather dull

Graphics: stick man animation

Sound: Goonie music plays throughout

Skill levels: one

Screens: eight

General rating: good two player game, but tough

Use of computer	59%
Graphics	55%
Playability	55%
Getting started	67%
Addictive qualities	61%
Value for money	50%
Overall	60%

LLOYD MANGRAM'S



FORUM

I'm putting the finishing touches to this month's FORUM on the evening before Bonfire Night — tomorrow night my peace will no doubt be shattered by endless pyrotechnic displays. But at least it will all be over for another year. I've been getting thoroughly fed up with local youngsters letting off bangers under the office window as I slave on into the night, trying to lessen the strain on my overloaded In Tray. (I hope it is the local youngsters, not the Ludlow Mafia dropping hints about the annual renegotiation of their rates now that Newsfield has four magazines.) Either way, at least their supply of gunpowder will be removed from the Ludlow shops ere long. . . .

A few weeks after you read this, it'll be THAT TIME OF YEAR AGAIN — a bumper 196 pages of Christmas Special will be unleashed on the world, and affixed to it will be Issue Zero of L.M. I hope you like them both.



OF CHICKENS AND EGGS

Dear Lloyd,
An 'original' CRASH reader here (I collected a few mail-order catalogues back in 1983, as well as all the 'proper' issues, of CRASH), with a slight moan. Why take the sudden decline in the pride of owning a Spectrum? For example, over 40% of my computer-owning friends have a Spectrum, and they all would prefer a 64! (I wouldn't).

Some recent letters to the FORUM from Spectrum owners (e.g. Paul Tyler and especially P A Rasbotham) have stated in no uncertain terms that the Spectrum as we know it (certainly the 48K versions anyway), will soon be cashing in their micro-chips. All right, the machine may have successfully out-lived the guesses of the wildest optimists and therefore will probably soon disappear into the realms of history. But if software companies forget about it entirely, (again, I refer to 48K models), their profits will drop faster than the prices of Acorn shares last year (Hal)

Glider Rider was a good idea, in that there are two separate versions contained on the tape, one for 48K machines and the other for 128K's, but what a shame that they relied on the sound for the 128

to lift the ratings above 'good' to the dizzy realms of Smash (well with 92% it was!). This consideration of the fact that the game on its own merits is just 'good' will surely persuade many 48K owners to buy something else instead. On the other hand, any prospective 128K buyers may be persuaded to buy the machine if many more games with the class of Glider Rider appear. . . .

My real point is this: Let's not be ashamed of owning a Spectrum, be it 48K, 16K or 128K. Just see what happened to the ancient armies when they lost a great deal of morale in a battle (don't laugh at that, the ancient civilizations had a lot to teach which is still true today). If we all throw our Spectrums away or cease to buy games for them, of course no-one will produce any software, for who'll buy it? There's life in the old machine yet, and the programmers 'definitely' have a few more surprises in store for us.

Sermon over, now moan No 2. A very few games, e.g. *Id* and *Deus Ex Machina* have received lengthy previews in CRASH, but no actual ratings! (Strange, they were both by Mel Croucher. . .) I thought that *Id* sounded like a great idea, but with no proper review and criti-

cisms, I decided not to buy (playing it in a shop is not quite satisfactory, if, as in *Id*'s case, the game requires lengthy trial). So please LM, kick the reviewers (yes, all of them, and yes, I do like using brackets) until they promise not to do this again. Really, though, that's a very minor moan, but it is annoying. . . .

Paul Hirdle, Lancing, West Sussex.

Quite right, too Mr Hirdle. It's refreshing to hear someone putting some perspective onto the debate about the Spectrum's viability for the future.

Clearly, there are a lot of Spectrums out there, and equally clearly, software houses are going to find it rewarding to continue writing good and innovative programs for the machine that has given so many people much pleasure. As the recently-elevated-to-higher-planes person, Graeme Kidd, said some months ago, it's a chicken and egg situation when it comes to launching any computer: the hardware won't sell unless there's a good range of software to run on it, and the software isn't economical to produce until a fair-sized user base is established.

Maybe Amstrad plan to phase

out the Spectrum Plus as well as the 128K machine, leaving the Plus Two as the only games machine bearing the Spectrum name available in the shops. If this is the case, all new Spectrums will be 128K machines. Software houses will find it increasingly profitable to produce games that take full advantage of the extra facilities offered on the larger machine. Good news for everyone — because it's unlikely that programmers and software publishers will be so foolish as to abandoned the 48K owners.

As for Mel Croucher's games. . . at the time we looked at them, they really defied reviews that follow the normal approach for mainstream games, which is why they weren't rated according to our 'formal' system. They were (and still are) somewhat ahead of their time, very different and worth investigating further.

I think you deserve the £20 of software this month for your cogent, well reasoned arguments. Auntie Aggie has been instructed to contact you in due course, Paul. There's an early Christmas present on its way to you. . . .

LM

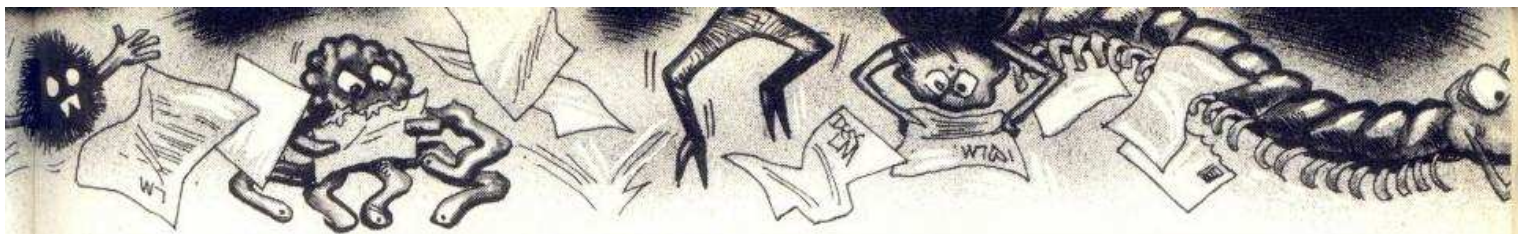

COMPANY SAGA

Dear Lloyd,
PSST! Have you heard about the software phenomenon? You haven't; right I'll tell you.

The INCENTIVE to produce software at the present time is huge; just IMAGINE the rewards to be reaped when sales of your new game CASCADE. Authors who write ADDICTIVE software are becoming a LEGEND in this GLOBAL industry, which is entertaining the NEW GENERATION. Every ACCOLADE is heaped on those who possess the VISION that enables them to become the ELITE in their profession. On the other hand, there must be some who go over THE EDGE or disappear FASTER THAN LIGHT in the VORTEX created by the OCEAN of new releases, all part of someone's DREAM to create the ULTIMATE work.

Who, in their wildest ELECTRIC DREAMS, could ever foresee that software would go BEYOND the Mainframes? Clive SINCLAIR and the pioneers who bought his masterpieces of DIGITAL INTEGRATION, and then gave our first tastes of alien-bashing; that's who. They started a NU-WAVE of EPX proportions, which evolved BRITANIA as a nation of games PLAYERS.

We all wanted to fly an INTERCEPTOR, plan our ADVANCE on Berlin, or pull our hair out, as we went MAD trying to solve the latest ADVENTURE. INTERNATIONAL products soon found ACCESS to our shores, and we wanted plenty of this US GOLD.

If you are still a VIRGIN, it's time to let the BUG-BYTE you; there are SOFTWARE PROJECTS to suit everybody. You may encounter the odd GREMLIN which will cause you to curse THOR or ODIN, but when the next ARTIC-load arrives at your local computer shop, you'll be first in line to get the new Number 1.

After all, where else could you swim with PIRANHAS or ALLIGATAS, duel with NINJAS, or shoot GARGOYLES, and all in REALTIME too. I dread the day when the BUBBLE BUSTS and the shops are no longer RAM JAM full with our favourite games. But even if the industry sank, like some latter day ATLANTIS, I have no doubt that the CREATIVE SPARKS in our schools today, would resurrect it, like the FIREBIRD of olden times. The SAGA is not over yet.

Aled Wynne Jones Owen,
Crewe, Cheshire.

POKE, POKEY

Dear Lloyd,
Sorry if my scrawl is almost illegible but bear with me. To the point:

Who does that jumped up prat think he is anyway. Yes I talk about the one and only Gary Hollo(w brain)way. In his letter in Issue 34 he rants on about how POKES are a waste of time and no self-satisfaction is felt when the game is completed.

Personally I think this is a load of irrelevant crap and is unjust. Without POKES Hannah Smith and Robin Candy (RIP) wouldn't have had jobs...

When POKES came in people were keen to use them. Since then the interest in hacks have increased. POKES are really just to help people having difficulties in a certain part of a game and it is up to the individual, whether he or she wants to type them in.

Although I don't use POKES much because I'm an ace game player (sorree! flashes of vanity there), I still feel enough satisfaction to have completed a game, POKE or no POKE.

Not all games can be completed that easily even with a POKE, you may still get trapped and have to

abort the game.

He also points out that people may go out, buy a new game, type in a POKE and inevitably complete it. What sort of jerk would do that? — no-one! People like him are degenerating the pages of FORUM.

Mark Langley, Eastbourne, East Sussex.

PS Hannah Smith is the most sexy, gorgeous, raunchy, words can't describe girlie tipster in the whole realm of magazine marketing.

Like I said last month, each to his (or her) own when it comes to POKES. Games are there to be enjoyed, and if POKES help that enjoyment then use them, and if they don't, then don't go to all the trouble of typing them in. Simple really...

And Hannah (our very own palindromic Tipster) wouldn't exactly take being described as a magazine marketing ploy, so I'd be careful what you say to her if you come to the ZX Microfair on 13th December — she's promised to come along for the day you'll be pleased to hear!

FOOTBALL MANAGEMENT STRATEGY GAMES from E & J SOFTWARE

48K SPECTRUMS

3 quality football games for serious enthusiasts. Each game uses the full available memory of your Spectrum or Spectrum+ and is packed with genuine features.

PREMIER LEAGUE

OUR COMPREHENSIVE AND EXCITING LEAGUE GAME — FEATURES INCLUDE: Training, Team Selection, Substitutes, Half-Time Scores, Full Squad Details, Named Goal Scorers, Team Styles, Save Game, Financial Problems, 5 Skill Levels, Transfer Market, Injuries, Continuing Seasons, Printer Option, PLUS MANY MORE!

EUROPEAN TROPHY

A SUPERB EUROPEAN COMPETITION STYLE GAME WITH THESE FEATURES: Home & Away Legs, Away Goals Count Double, 2 Substitutes Allowed, Extra Time, Penalty Shoot-Outs (with sudden death), Match Injuries, Injury Time, Match Penalties, 5 Skill Levels, Pre-Match Reports, Team Selection, Named Goal Scorers, Save Game, Printer Option, PLUS MANY MORE!

★★★ SPECIAL FEATURE ★★★

Transfer your PREMIER LEAGUE winning side into EUROPEAN TROPHY

Both these games can be played separately or as COMPANION GAMES

★★★ Games £5.25 each ★★★

SPECIAL TWIN PRESENTATION PACK OF BOTH GAMES AVAILABLE AT ONLY £9.95

and now! WORLD CHAMPIONS

An exciting World Cup Football Management simulation taking you from the first warm-up friendlies through the qualifying stages, Tour Matches and onto the finals. LOOK AT THESE FEATURES! Select Team from Squad of 25, Pre-Match Team News, Disciplinary Table, Full Results List, Match Suspensions, Change Player or Team Name, League Tables, 7 Skill Levels, Save Game, Printer Option, PLUS MANY MORE!

WORLD CHAMPIONS features a superb comprehensive text match simulation including the following: Match Timer, Named Goal Scorers, Goal Times, Corners, Free Kicks, Injuries, Bookings, Penalties, Sending Off, Injury Time, Extra Time, Penalty Shoot-Out. ★ ALL THIS AT THE UNBEATABLE VALUE OF £8.95 ★



All games now in stock for immediate despatch — order your copies now!

FANTASTIC VALUE — ORDER ALL THREE GAMES FOR ONLY £15.95

All prices include postage and packing (add £1.00 outside UK). Available by mail order only.

**E & J SOFTWARE, Room 3,
37 Westmoor Road, Enfield, Middx, EN3 7LE**

LOTHLORIEN

NEW DEATH IN RUSSIA 1941

- German invasion Operation Barbarossa
- All graphic 1 player wargame
- Scrolling Maps
- Simulates Eastern Front 1941—43
- Retail Price only £7.95

NEW DEATH IN THE SNOW 1812

- Napoleon at Borodino
- Sequel to Waterloo and Austerlitz (Crash Smash)
- 1 player all graphic wargame
- Features separate artillery units
- Intelligent corps commanders etc
- Retail Price only £7.95

Available from all good software shops or direct by post

SPECIAL MAIL ORDER OFFERS (SPECTRUM)

Waterloo £6.95 normally £9.95
Austerlitz £9.95 + free game Overlords £5.00 + free game

M C LOTHLORIEN LTD, Icon House, 381 Bury New Road, Prestwich,
Manchester M25 2AW. 061-773 1068

I enclose a cheque/P O made payable to M C Lothlorien Ltd

Please debit my Access/Visa No. _____

Signature _____

Name _____ Address _____

Post Code _____

M C LOTHLORIEN LTD, Icon House, 381 Bury New Road, Prestwich,
Manchester M25 2AW. 061-773 1068



IT'S HOW YOU USE IT

Dear Lloyd,
I thought I would write in to give you my views on P. A. Rosbotham's letter (November's Forum), which was pretty harsh on both the 48K and 128K Spectrums. It may be true that the Spectrum is outdated. It is true that it has colour problems and poor sound (on the 48K). But isn't that to be expected? Spectrums were around at the time of the Vic 20, and look how far that box of old bolts got.

When P.A. says that attribute clash and poor sound are incurable, does he (or she) realise that this isn't true? Just look at *Lightforce*, reviewed the same issue. Where's the attribute clash? And there have also been programs in various mags to give more than one colour per attribute square — one in YS a while back, and, of course, one for the 128 a couple of months ago!

As for sound . . . well Okay, the 48K beeper ain't wonderful, but some pretty nifty effects have been done before.

And to say that 128 sound isn't much better is pretty daft. So the AY chip isn't as good as old SID in the Commie, but so what! If you're playing games then you don't care if the chip has redefinable envelopes or whatever anyway! And I'm sure that this will soon change when the programmers get to it, just as much as 2 channel sound became possible on the 48K. And as to the computer halt-

ing while playing a note, has P.A. read issue 32's TECH TIPS? Thought not!

To round off, I can confirm that the 128's keyboard is BETTER than the Plus keyboard, because I

own a 128 and my brother and sister have a Plus. And unlike P.A. Rasbotham I CAN recommend the 128 (to everyone), especially when you can pick them up for a measly £100 in some shops!

All in all, I hope that very few people agree with P.A.'s letter —

we should be proud at the Spectrum's good points (and there are lots!) and not moaning about its deficiencies!

David Clark, Kilconquhar, Fife.

Alan Batty has much the same thing to say elsewhere this month, and there's little I can add to your comments David

LM



AMSTRAD DISAPPOINTMENT

Dear Lloyd,
I bought my son's 48K Spectrum about 2 years ago, and as it's been used just about every day since then, it's been excellent value for money, and I've been thinking about buying the 128K Spectrum.

Like many other people, I was disappointed to hear about the number of 48K games that will not work on the new computer, but the news of an improved Amstrad version raised my hopes, and I awaited the reviews.

After reading Simon Goodwin's report in October's CRASH, I'm disappointed again. The only

real improvement seems to be the keyboard. The integral cassette deck sounds horrible: no tape counter, very slow rewind, and extra small pinchwheel. Let's face it, no one would buy a tape recorder like that. A big disadvantage is the lack of an external tape socket, which it would seem to really need. Add to this the fact that you need adaptors to allow your existing joysticks to work, and that add-ons might not fit into the deeper recessed connector, and there's a good case for re-considering the original 128K.

Everyone who has a 48K Spec-

trum also has a tape recorder, so there's no problem there. I've read nothing about the 128 Plus 2 being able to load more 48K games than the original 128K, so unless I've got my facts wrong, I'll be keeping an eye on the price of the first 128 Spectrum, and leaving the Amstrad version alone.

P. Haw, South Shields, Tyne and Wear

Well, the Plus Two does seem to have entered the market suffering from the same sort of teething problems encountered by earlier Sinclair Sinclair products.

Simon Goodwin points out how

you can connect up an ordinary tape recorder to the Plus Two in TECH TIPS this month, but the snag is you have to invalidate your guarantee. But how else do you get a awkward tape to load . . .

Certainly the 128K Spectrum represents particularly good value at the moment, but several people have written to me saying that the old rubber keyed Spectrums, and sometimes even Pluses can be bought for around the £50-60 mark.

Perhaps there's never been a better time to buy a Spectrum?

LM



- T**wo worlds – the mirror image of each other, touch in space through a Time-Warp.
- ©**ne is positive, good, familiar – our World; the other is negative, evil yet unnervingly familiar.
- T**heir interface – a time window through which objects and beings can pass; contact has resulted in the beginning of exchange.
- R**estore our World – stop the invasion, but do it now, for as the exchange accelerates, the time window grows larger – domination is a hand!

DOUBLE DONBTE TAKE

STARTLING ACTION · INNOVATIVE GAME PLAY · STATE OF THE ART 3-D GRAPHICS



6 Central Street • Manchester M2 5NS • Tel: 061 834 3939 • Telex: 669977



DEFENSIVE WORDS

Dear Lloyd
If ignorance is bliss, P A Rasbotham must be very blissful. His letter in Issue 34 FORUM made my blood boil.

I've owned a 48K Spectrum for three long years, and whereas I wouldn't say it was over the hill (though from where it's standing it gets a good view of the valley) I decided it was time for an upgrade.

I decided to buy a cheap Spectrum 128K as opposed to the appalling Plus Two with its 'quality' Amstrad tape deck. This machine hasn't merely got more memory than the old Spectrum but also has menu driven basic with full screen editor to name but a few of its goodies, and of course a pseudo 48K mode.

128 games are often a vast improvement over the 48K originals, and add a new dimension to their playing (I refer to *Glider Rider* — need I go on?)

As to his attack on the 'prehistoric' sound chip, he may be reminded the SID chip isn't exactly in diapers anymore, I'm also a proud owner of an Amstrad 6128,

and believe me, the sound on the 128K Spectrum is a vast improvement on the Amstrad's, due to it being modulated onto the television signal, and yes it does come up to the Commie's standard more often than not.

So I think 'people' like this Rasbotham should stick to their extravagant Commies, and not be so quick to dismiss the Spectrum 128, or indeed it's distinguished predecessor.

Alan Batty, South Darenth, Kent

When it comes down to it, there's no empirical way of settling such disputes — each computer has its relative merits and shortcomings, but as I said last month it's not so much what the computer itself offers, it's more to do with what can be done with it. The Commodore, Amstrad, Spectrum (and romping into prehistory myself for a moment, even the Memotech, Oric and the like) all have different potential to amuse, entertain and educate. My mother always used to remind me that you shouldn't be quick to dismiss anything out of hand...

LM

EAGER BEAVER

To Lloyd,
On the 14th October I saw that Jon Eggleton had at last achieved TV fame (well TELETEXT Channel 4 P 557). Here is what it said.

"*Kat-Trap* is the result of an award-winning game design submitted by Jonathon Eggleton to the Crash GENESIS competition and was selected from 4,000 entries by a panel of judges.

"The program gives a fast and furious romp through a myriad of scrolling screen sets, with the player controlling a mechanical, cat-like robot with Springy legs.

"*Kat-Trap* will be available next month on Spectrum at £8.95 and Amstrad CPC at £8.95 (cassette) and £14.95 (disk)."

How about starting an eager beaver award and giving me the first one?

P Sankey, Walton, Liverpool.

Another strange Christmas present request. Anyone would think I was Santa Claus...

LM

MINIMALIST APPROACH

Dear LM,
Every issue we read letters from readers offering their opinion as to how CRASH can be improved. I would like to offer my two penny worth — get rid of reviews, Crash Course, charts, Frontline, Playing Tips, Fear and Loathing (especially Minson's garbage) and hand the pages over to the star of the show... JETMAN.

Dave Bates, Solihull, West Midlands.

PS Jetman would be a good title for the new format magazine.

Fine for Jetman fans, but just think of all the other magazines we'd have to bring out just to keep everyone happy.

And just what's wrong with MY initials?

LM

CUTHBERT THE COMMODORE OWNER

WITH SAM THE SPECTRUM OWNER and BRIAN THE BBC OWNER

BY CHARLIE BROOKER - OXON

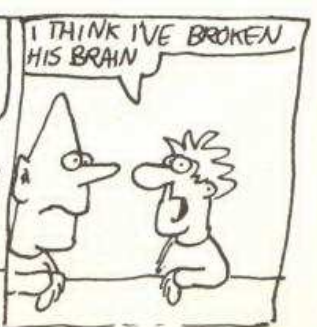
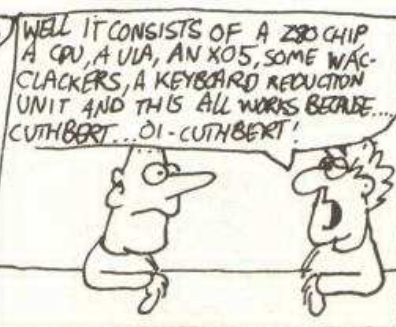
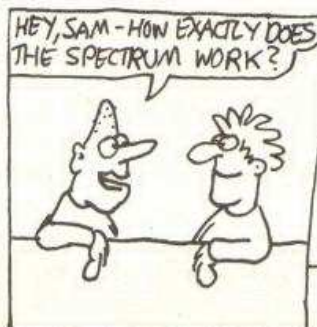

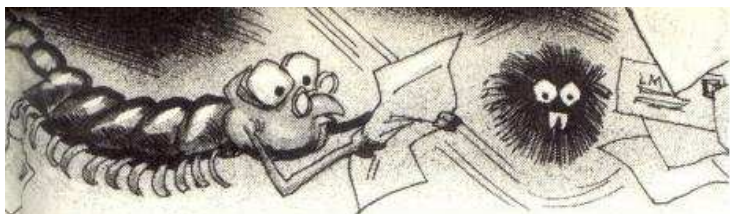

A DIFFERENT PERSPECTIVE

Dear Lloyd,
Everyone seems to be complaining about all the 3D games in the market. This seems to me to be especially silly when you consider that in issue 33 you reviewed six times more 'boring old 2D games' than 3D ones. Whether everyone has been especially dim or not, nobody has realised that 3D is here to stay and will be the industry standard in 12 months time. Anyway, what's wrong with 3D? 2D is dead! Long live Filimation (c).

Yours in perspective,
Robert Lines, Comer Lane, Gosport, Hants.

I not so sure about the 'Industry Standard'... but there's certainly plenty of life left in the Knight Lore type format as programmers such as Jon Ritman of Batman fame continue to show.

LM

BY STEPHEN HUDSON
CHESHIRE !!!



EVIL PENN 'N'RIGNALL

Dear Lloyd,
Someone has been messing around with the wordsquares again. Not content with messing about with the *Exploding Fist* wordsquare (printing ZZAP RULES OK on the bottom line) some person has gone and put in the left hand column of the *W.A.R. Wordsquare* ZZAPYRULHESOKW. Takes out the Y, H and W and what do you get — ZZAP RULES OK.

Is the Comps Minion going bonkers? Does he like ZZAP! more than CRASH, or have the evil Penn and Rignall been up to their tricks yet again? Whoever it is, I'm sure the Ludlow gibbet could do with another person!

Stephen Coby, Halesworth, Suffolk.

The Comps Minion has just come up to the CRASH office, bearing a tray full of tea — a cup for everyone. It was totally unsolicited, so I don't think he has anything against CRASH. (He must be in a particularly good mood — maybe he's just finished writing all the competitions for the next issue

... it's a clear case of the Spiky Haired Ones putting their Spikes in, as far as I can see.

LM

OVERCHARGED

Dear Lloyd,
I just had to write after reading **Robert Hayden's** ridiculous letter in the November issue of your well known broadsheet. This moronic prat actually seems to ENJOY giving all his money to the overcharging software mega-corporations. What a wally! There were plenty of decent games in 1983, my dear Hayden (maybe you still hadn't been born) the difference was that the software houses didn't spend all their money on hype, meaning lower prices. Pathetic little creeps like you, Hayden will only succeed in convincing people like **ULTIMATE** (remember their 100% price increase?) and others that they should double their prices. **Electrostatically yours, Zenith Kodachrome, Planet X.**
PS Don't you think that **Ultimate** have turned in to computer version of **Status Quo**?
PPS Isn't this an aggressive letter?

Plenty of decent games in 1983, certainly, but three years ago £5 bought a lot more than £5 does today. And the quality of software has, largely, improved as a result of more effort, time and money invested in the development of games. These two factors are bound to lead to higher prices, but admittedly not all 'full price' games released today improve on the standards of 1983. Most of them do, however, which is why I still agree with Roberts's sentiments.

And no and Yes.

LM

elite

PROGRAMMERS!

YOUR No. 1 OPTION GUARANTEED ON

Finished Product Publishing

Free Lance Contracts - Original Concept or Conversion

"In-House" Programming

With exceptional distribution in the U. K., Europe, and expanding markets around the world "Elite" and "2.99 Classics" can guarantee to offer the very best terms on all forms of finished product and programming/publishing agreement.

Here's Why?

It's quite simple. To get the very best products and programmers we offer the very best terms around.

Take up the Challenge

Finished Product Publishing - Our reputation for quality on both the "Elite" and "2.99 Classics" labels ensures the highest profile for the product. With a choice of either outright payment or monthly royalty with a guarantee, its got to be your No. 1 option.

Free-Lance Contracts -

Original Concepts - Elite offer financial support to proven programmers and development houses wishing to create original product.

Conversion Contracts - We can also offer the very finest titles for conversion, again on a fixed payment or monthly royalty with guarantee basis. Around £10,000 per project is quite achievable.

"In-House" Programming Opportunities -

Looking for a change?

Both "Elite" and "2.99 Classics" can offer In-House programmers the opportunity to work on both salary and salary with royalties. Solid support from "In-House" graphics and sonics people makes a great working environment.

ACT NOW !!

Finished Product - Send by recorded delivery samples and relevant documentation for an immediate decision.

Free-Lance Contracts/In-House Programming -

Advise us by 'phone, telex or post of your experience with details of published/soon to be published work (if applicable) and samples where possible.

Then let us know the area of your interest and if it matches with ours we'll arrange an immediate meeting.

Contact - Software Development.

Elite Systems Limited.,
Anchor House, Anchor Road, Aldridge,
Walsall, West Midlands WS9 8PW

Tel: (0922) 55852 Telex: 336130 ELITE G



CRASH BANG WALL-O-P!
 PRODUCTIONS PRESENTS
THE BUGS TAKE LUDLOW

by William (nurtz) Thompson ← THAS ME!



A SPECIAL HELLO TO STANET (THE CROTE EGYPTIAN) PRIS (THE CHOTE CROSSENER) AND TUDJIT (JUST CHUTE) WHO CONTRIBUTED ABSOLUTLY NOTHING TO THIS CARTOON!!!



ALIENS

T H E C O M P U T E R G A M E

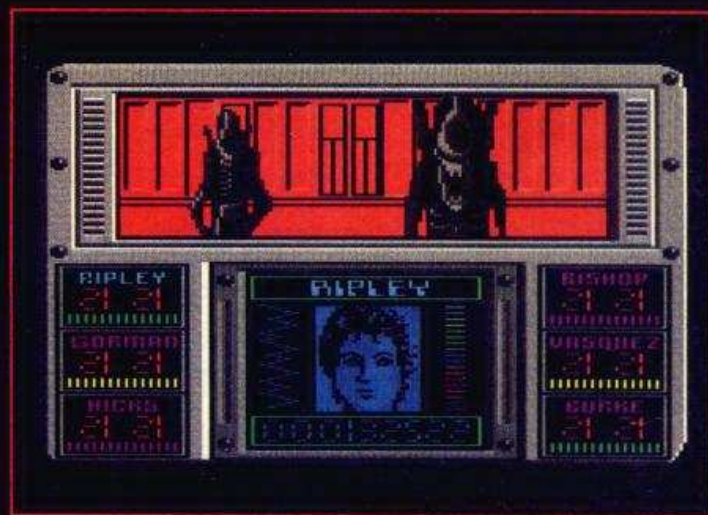

COMMODORE SCREEN

There are some places in the universe you don't go alone.

AVAILABLE ON

ZX SPECTRUM 48K/128K/+	£9.99	AMSTRAD CPC Cassette	£9.99
COMMODORE 64/128 Cassette	£9.99	AMSTRAD CPC Disk	£14.99
		COMMODORE 64/128 Disk	£14.99

ELECTRIC DREAMS SOFTWARE, 31 CARLTON CRESCENT SOUTHAMPTON SO1 2EW. TEL (0703) 229694

Mail Order: Electric Dreams Software, 23 Pond Street, Hampstead, London NW3 2PN.

Electric Dreams

S O F T W A R E

© Twentieth Century Fox

FROST BYTE

by

mikro
GEN

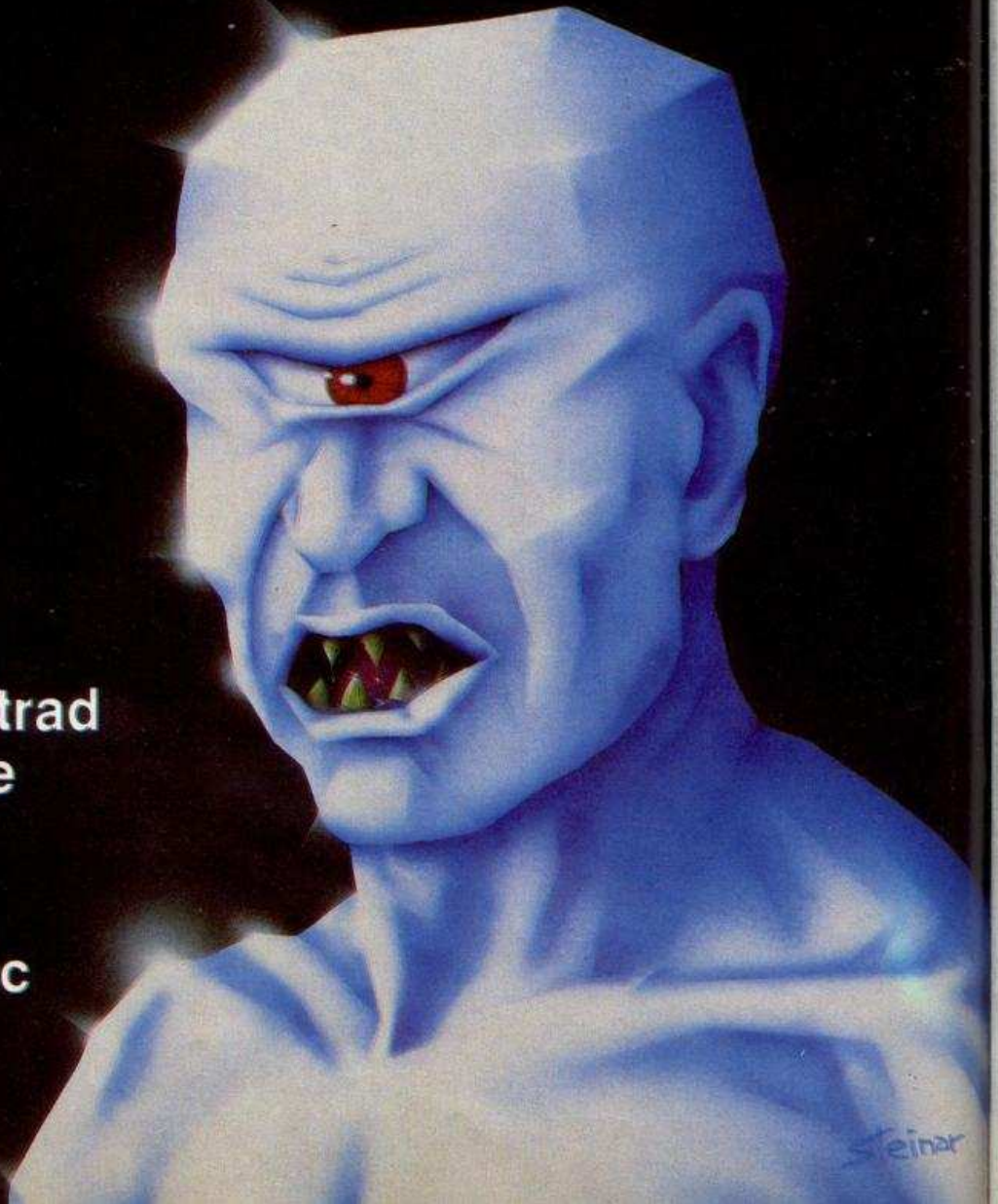

Spectrum Amstrad
Commodore
Cassette
£8.95
Amstrad Disc
£13.95

Steinar



BY MARK HARRISON

BAD TASTE

Dear Lloyd,
I was playing on the new **MASTERTRONIC** game *Video Olympics* when I saw an advertisement like the 'Coca Cola' sign, but in fact, when I looked closely it said 'Cocaina'. Well it isn't very funny as a joke because it kills hundreds upon hundreds worldwide every year. In my opinion it is a sick joke and I shall be very reluctant in buying future **MASTERTRONIC** games.

Yours not laughingly
Jason Lindsay, Anfield, Liverpool.

*Doesn't sound very clever to me either, Jason. I haven't been able to talk to **MASTERTRONIC** about the*

*point you raised, and haven't actually played the game in question myself. But I'm sure it's not the kind of thing the Powers That Be at **MASTERTRONIC** would approve of. Often such little 'jokes' are put into programs (and sometimes the files of typesetting prepared for our very own ART department) and the perpetrators intend them to be intercepted.*

*The silly part of doing such things, is occasionally someone's attention wanders and something that shouldn't slip through in the heat of a busy moment. Maybe someone at **MASTERTRONIC** would like to pass comment?*

LM

THE TOP SLOT

Dear Lloyd,
I am writing to you in reply to R J West's letter in the October issue of **CRASH**.

I too was an **ULTIMATE** fan until the release of *Pentagram*, (incidentally, why was this boring game Smashed?). I disagree with his view that **ODIN** are the leading software house in the country. Has he forgotten the likes of **MELBOURNE HOUSE**, **BUBBLE BUS**, **OCEAN** and in my view the best of the lot, **ELITE**?

These four companies, with the possible exception of **BUBBLE BUS** (although *Starquake* is definitely a classic), have all had a long list of excellent games behind them, for example *The Hobbit*, *Ghosts 'n' Goblins* and, of course *Match Day*, these three games are all classics.

I admit that **ODIN** are a good company with obvious programming talents, but you need a lot more excellent games (ie **CRASH** Smashes) than three to become the country's leading software

house.
Simon Davis,
Hemel Hempstead, Herts.

The accolade of 'The Country's Leading Software House' is one that could be rested on several sets of shoulders — it all depends on when you seek to make the award. For instance **BUBBLE BUS** and **MELBOURNE HOUSE** seem to have gone into a bit of a lull recently, and we've seen nothing

for ages from **ULTIMATE** (although they're rumoured to be doing work for the Japanese games consoles made by **NINTENDO** at the moment).

I'm not going to let you have my nomination for 'Leading Software House' — it wouldn't be fair to pre-judge the result of the Annual **CRASH** Readers' Awards. Voting forms will be available in the Christmas Special in a few weeks' time, so if you feel strongly on the subject, make your voice heard!

LM

THE BOSS

Electron/BBC B £8.95, Amstrad £8.95 (disk £9.95), MSX £8.95
Spectrum £6.95, Commodore 16 £6.95, CBM 64 £8.95 (disk £9.95)

!! IT'S IN A DIFFERENT LEAGUE !!

The most complete, compulsive and entertaining football management game ever!

- 4 divisions • FA Cup • European Cup • European Cup
- Winners' Cup • Promotion/Relegation • Transfers
- Suspensions • Injuries • Substitutes • Name team • Team selection
- Choose/change team formation • Weekly league tables • Reserve squad

Check with your retailer, phone your Access/Visa number or just note your name, address, computer and game required on the back of your cheque or P.O.

PEAKSOFT 48 QUEEN STREET, BALDERTON
NEWARK, NOTTS.
Tel: 0636 705230

SH

GREAT GAMES FOR CHRISTMAS GREAT VALUE FOR MONEY NIGHTMARE and POTHOLER

Two superb educational adventure games for juniors

'Crash' says: 'Outstanding... don't miss them' (Oct '86)
'Educational Computing' says: 'Two excellent programs' (Mar '86)

Orders to:
SOUTHWAY SOFTWARE, 16 May Terrace, Plymouth PL4 8PP

Please send tape/s containing
Nightmare and Potholer for Spectrum 48k @ £6 each. Total £ ...

To: please use BLOCK LETTERS

..... Post Code

Please include cheque or P.O. payable to **SOUTHWAY SOFTWARE**



LAW ABIDING

Dear Lloyd

I am just writing to make a BIG point. Computer games can be very expensive (eg £9.99), when they could be quite cheap. Lots of money is spent on advertising and promotion. If this was not so, games would be cheaper and more people would buy them. For instance, 8 out of 10 of my friends copy games that are quite dear, but only 2 out of 10 copy games with the price tags of £1.99, £2.99 (cheapskates). If the games were cheaper, England would be a more law abiding country and the game manufacturers just as rich.

Simon Green, York.
PS Happy Christmas

Thank you for your kind sentiment Simon — you're the second of the season to pass on such greetings (Gareth Jones came in first with the earliest Christmas card this year.)

Your argument that it is the manufacturers who make criminals out of people really doesn't make too much sense — people generally break the law by choice. There may be some merit in the argument that stealing food if you are starving and have no money to buy anything to eat shouldn't be considered criminal, but pirating games just because you can't afford them is definitely a criminal act. I can't afford the Rolex Oyster watch on display in the Ludlow jewellers, but that doesn't mean I have the right to steal it just because I can afford a Swatch...

Advertising and promotion does cost money, but without it customers don't get to know that a game is available for sale and shops won't stock it. It's doubtful that manufacturers would be able to sell vast quantities of cheap games and still make enough money to fund the six month's development work that commonly goes into a full-price game. So the quality of games would suffer, and it's the players who would suffer in the long run.

LM

CODE LOADS

Dear Lloyd,

Just a few words about the 128K Plus Two. I would like to congratulate Amstrad for producing this machine. The colour is good and no more of this shifted key crap. The only thing is the name "Spectrum 128K Plus Two" I mean couldn't they think of some name. I am going to call mine 'Christine'! When reviewing games will you print what the program runs on. You could use this code:

48K+A; 48K Plus+B; 128+C; 128

Plus Two+D

and then print on the review 'Computer C, D only' for instance. Well that's all I want to say.

Michael Quone.

PS If you print this letter it would be a good hint for my Mum on what to buy me for a Chrissie present!

Whatever do you want a load of A's B's C's and D's in your Christmas stocking for Michael?

Cameron Pound, the CRASH 'Ace Lensperson' uses a 128K Spectrum in his photography room (which incidentally is now the old CRASH office. We've moved into the old Newsfield boardroom which Hannah is doing her best to

clutter up with PLAYING TIPS FOLDERS, sandwich wrappers, Girlie Tipster stickers, bottles of Perrier and Malvern water and all the other things she seems to need around her to survive the day. There's so much space, even she's having difficulty filling it!

Getting back to the point, though, Cameron lets us know if he has any problems loading games on the 128K and so far he hasn't run into many. At the moment, we'll probably just report on problems we encounter rather than introducing a new system, but who knows what the New Year will bring?

LM

THE CRASH TASTE TEST

WE STOPPED A PASSING-BY, ER, CREATURE IN THE STREET AND ASKED HIM OR, ER, HER, WELL, IT, TO TRY 3 LEADING MAGAZINES...

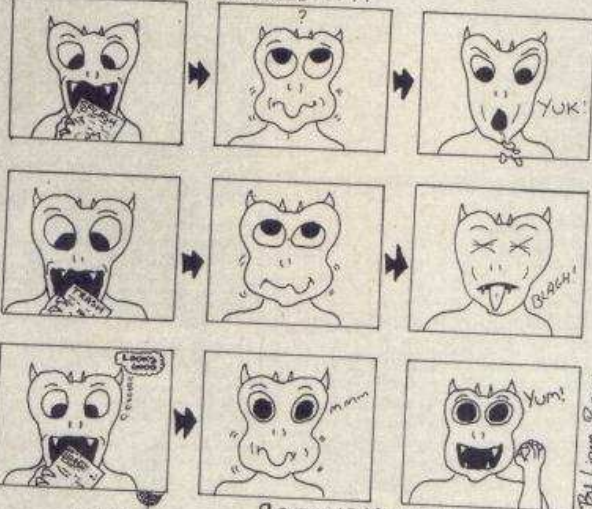

9 OUT OF 10 MONSTERS PREFER CRASH.



By Richard Hull



BORED TO DEATH?

Dear Lloyd,

I wish to say how disgusted I am with Software in general. Although the standard of graphics and sound is excellent. Almost all software (99% of it at least) is the same.

It's all either shoot the little men, an escape to freedom, save the world with a magic book, destroy the evil machine, or collect all the keys... and it's all very boring.

I think that the best games I've ever played are *Deus esc Machina* and *Movie* (I know that *Movie* is an arcade adventure, but it's got orig-

inality of plot and loads of atmosphere).

I'm afraid, that because software houses are too afraid to try something radically different from the same old humdrum, that computers will die out. This would be a great shame because a lot of enjoyment can be derived from playing a game or from programming. And now with the arrival of the 128K and 2 Spectrums a whole new set of opportunities have appeared. (Before all the 48K owners think oh no! Here's another one raving on about his 128K.

Well, I don't have a 128K. I have a Spectrum)

So come on OCEAN, US GOLD, IMAGINE, QUICKSILVA and all the others, lets see some new and interesting concepts tried out. You may not get it right first time, but think of it as a long term investment in your future. Long live NU WAVE and Mel Croucher.

Richard Fitzpatrick, Ballinalea Ashford, Co Wicklow

I'm all for innovation myself, but the sad fact is it doesn't always prove commercially viable. Mel

Croucher would be the first to agree — sales of *Deus* were pitifully low, even though it collected a host of awards for originality.

There are only a handful of basic games according to Mel Croucher and everything else is derivative to some extent. As long as people are happy buying highly derivative games that are produced to a formula, people will keep writing them and selling them. Now and again there are some different moves made, perhaps like *Trapdoor* from *PIRANHA*, but innovation tends to happen gradually rather than via Quantum Leaps.

LM

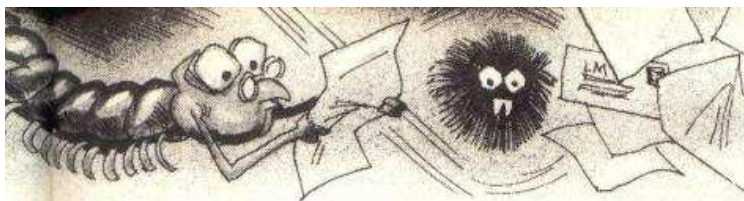

ONE FOR THE RECORD?

Dear Lloyd,
There have been quite a few letters complaining about games like *Street Hawk* being advertised months (in this case, over a year) early, but I think that **DIGITAL INTEGRATION** must hold the world record. Look back to the November 1984 issue of *CRASH*. On page 158 of this issue *TT Racer* was advertised: this was not previewed until September or reviewed until October 1986.

Please print this letter, as I was so wide awake in noticing this, and

cos it's my Birthday soon. Sorry about the bad writing, but I'm only 12 (13 soon), and I've only written one letter before. Gotta go — here comes teacher.
Zerbal, Belfast, Northern Ireland.

Better a game be late than never arrive, Zerball! I'm not sure whether you do deserve a World Record... Any statisticians out there care to re-read some CRASHes and let me know if there's a challenger?

LM

A TISSUE OF



FABRICATION!

Dear Mr Mangram,
I would like to point out some things that have come to my attention concerning your magazine. First of all, since Issue Four the paper has become considerably thinner, and yet you say that you need to raise the price to subsidise the ever rocketing price of printing paper. If you raise the price then surely you can afford to keep the quality of *CRASH* up to it's usual high standard — it is now more like single-ply tissue paper than part of a first-rate magazine. Please remember some of us have to back our school books in it — apparently the only use for advertisements.

Not that I disagree with the price, it offers much more value than other magazines I could mention, but c'mon Lloyd, what's happening? Is the extra money going towards the "Lloyd Mangram pension fund", or even the "Lloyd Mangram holidays in the Bahamas" number.

Now for some other points: first of all since **Hannah Smith** was appointed 'head of playing tips', this section has (in my opinion) improved ten-fold. (a mighty blow for fem.lib). I don't know whether this is due to Hannah being a superior tipster than **Robin Candy**, or because more tips are being sent in and the standard is generally higher. One last thing — your FORUM seems to be taking

over the whole magazine, it will end up containing nothing but Forum.

Thanks for reading and keep up the good work!
Paul Sarson, Oughtibridge, Sheffield

Pensions? Holidays?

Just because you've got wind of the fact that the Power That Be came to some small arrangement concerning the use of my initials on a new magazine (Available free with the Christmas Special — as they keep telling me to say), it doesn't mean I'm treated any better.

*Besides, I think you must be suffering from some strange tactile illusion, Paul. I checked the substance of your allegation with the Production Department and they assure me the quality of the paper used in *CRASH* hasn't changed for over two years. For the technically minded, the cover is printed on 115gsm coated paper, while the pages use 60gsm WSOP (whatever that may be).*

Hannah asks me to tell you that she's flattered, but doesn't believe she's been striking blows for fem.lib. She might have struck a blow or two for Girlie Tipster lib, but a certain Dame kept backing down. Without the help of readers, though, any tipster is bound to have problems...

LM

And that's another collection of your letters dealt with. With a bit of luck, I should manage to get all my work for LM and the Christmas Special done in time to do my Christmas shopping by post. It takes a long time to decide what to buy for whom, but shopping for presents from a catalogue is infinitely preferable to fighting

through the seasonal crush in town. Almost as pleasant as leafing through the 1987 Suttons Seeds Catalogue.

Don't forget, send your opinions, praise and pension fund contributions to me at **LLOYD MANGRAM'S FORUM, CRASH, PO BOX 10, LUDLOW, SHROPSHIRE, SY8 1DB**

For Your SPECIAL OFFERS SPECTRUM/PLUS/128K

QuickShot II

INCLUDING INTERFACE
PLUGS STRAIGHT INTO SPECTRUM/PLUS

ONLY **£13.99** POST FREE

- TOP + TRIGGER FIRE BUTTON
 - AUTO FIRE MODE
 - KEMPSTON COMPATIBLE
 - STABILIZING SUCTION CUPS
 - SPECTRUM OR PLUS + UNBEATABLE OFFER
- SEND FOR INSTANT DESPATCH



PRICE BREAKTHROUGH SWITCHABLE JOYSTICK INTERFACE

ONLY **£8.99** POST FREE

- ALL THREE SYSTEMS AT THE FLICK OF A SWITCH
- 'KEMPSTON' - 'CURSOR' - 'INTERFACE II'
- ACCEPTS ANY 9 PIN JOYSTICK - INCLUDING RAPID FIRE MODELS • SPECIAL OFFER!!

Buy with QUICKSHOT II complete for only **£14.99** SEND NOW



Now you can backup all your Spectrum Games to Microdrive or Tape.

- Simply press a button to "freeze" the program.
- Save to micro drive or tape.
- Special program compressing techniques
- Code Inspector allows you to freeze the action, add pokes and restart the game again. Also peek facility.
- All backups will restart from the point they were saved.

IMPROVED MODEL!
ONLY **£24.99** POST FREE

ROBOTICS & MODEL CONTROL

Made easy on your Spectrum

- 4 independently controllable outputs for robotics, motors, lights etc.
- 8 independent inputs for sensing etc.

£29.99 POST FREE



Now you can create Superb Graphics easily with



the New **Lightwriter**

NOW ONLY **£14.99**

POST FREE

Lightpen comes complete with

Interface & Software

- Just plug in the Datel Lightwriter and draw circles, squares, rectangles, make superb hand drawings, paint, fill, erase, choose inks, paper, colours.
- Save your results into memory (128K) and use in animation or save onto tape to use in your own games.
- All functions selected from screen menu with the lightpen.
- Unbeatable value. • Nothing more to buy.

SEND NOW AVAILABLE FOR IMMEDIATE DELIVERY

Digital Sound Sampling Technology. NOW Available on your Spectrum

Complete unit and Software Package

ONLY **£49.99** POST FREE



New Fully Integrated Software Supplied - Previous purchasers can upgrade for £5.00

• Digital Sound Sampling has only previously been available for large money and costing at least 10 times the amount. • The sound Sampler allows you to record "Digitally" any sound into memory and instantly replay it at any pitch, forwards, backwards, ascending scale, compressed, expanded, with echo, instantly looped etc. • Supplied complete with Software package to facilitate the above operations, plus on screen "Voice Photo" - Frequency Monitor. • With on screen keyboard - drum kit & whole system symphony could be produced from a single Sample Sound. • This is a professional unit featuring a 64K 12 bit ADC converter as used in Digital equipment now sweeping the music world. • Although the unit is not a toy, giving truly astounding results for the musically inclined, we have incorporated a games interface to allow you to use Sound Sampling in your own games etc. • So the Sound Sampler would be of interest to everyone.



Games Ace features:
KEMPSTON COMPATIBLE • JOYSTICK INTERFACE
ACCEPTS ANY 9 PIN JOYSTICK INCLUDING RAPID

FIRE MODELS
PLUS DELIVERS THE SOUND FROM YOUR GAMES THROUGH TV SPEAKER. (Fully controllable)
ONLY **£10.99** or complete with QuickShot II
only **£17.99** POST FREE

Centronics Printer Interface

ONLY **£24.99** Post Free

AVAILABLE NOW!!

UNBEATABLE OFFERS



- Suitable for any Centronics Printer
- Complete with Printer Cable
- Microdrive Compatible
- Tasword Compatible
- Hi-Res Screen Dump (Edson) Easy to use



DEPT No. **DATTEL**
USUALLY SAME DAY DESPATCH ON ALL ORDERS
SEND CHEQUES P.O.T.T.
UNITS 819
FEN1 ON INDUSTRIAL ESTATE,
DEWSBURY ROAD, FENTON,
STOKE ON TRENT TEL: 0782 273815
FAX: (0782) 264510

24 HR CREDIT CARD LINE
FORWARD ORDERS ADD 10% POSTAGE

Copies of the latest releases
from **THE EDGE** up for grabs!

**TRAVEL SHAO LIN'S ROAD
AND WIN A KUNG FU SUIT!**

**Learn the Mysteries of
the Shao-Lin Temple!**

**Crash
Competition**

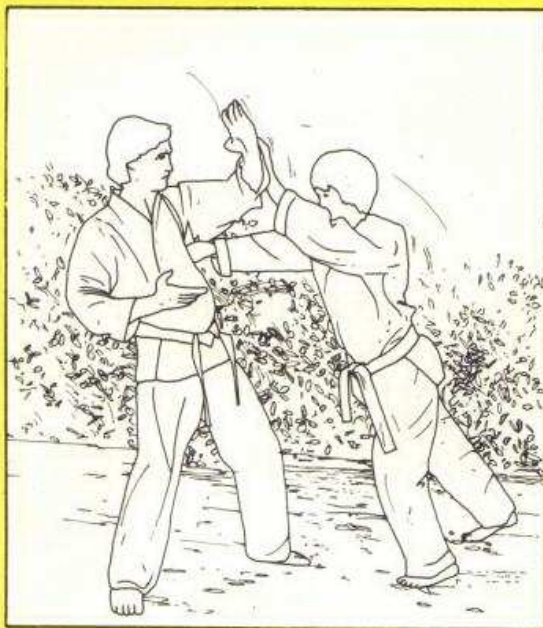

PICTURE A

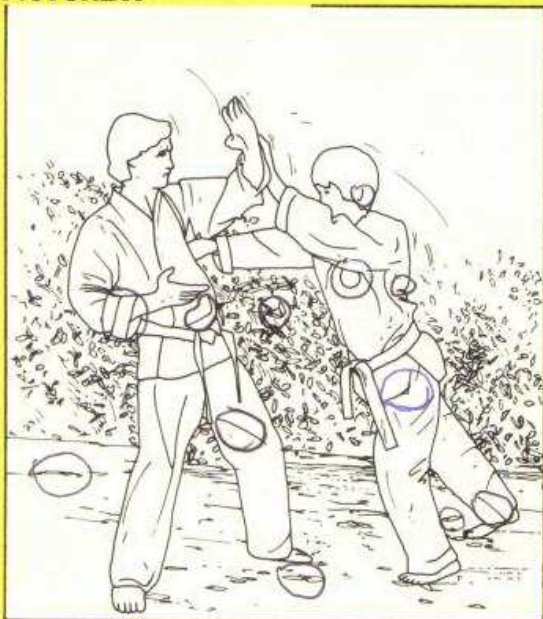

PICTURE B

No, you're not experiencing Déjà Vu, well you are to a certain extent, but not in the way you think. If you reckon you've seen this competition before somewhere before you're absolutely... right! Ten points for anyone who noticed our deliberate mistake in last month's Shao Lin's road competition. The poor little laddies were so busy Up In Art that they failed to notice that there were in fact no differences in the competition at all. Smacked handles all round. Anyway, for all of you who spent ages trying to figure out what the differences were here's the competition again.

Of course, me as Comps Minion got all the blame as usual. Even though it was nothing to do with me, everyone immediately started hammering on my broom cupboard door demanding to know why there were no differences in the competition. Graeme was really horrible to me and filled my sandwiches with washing up liquid and I didn't even notice until I was half way through the second one. Girlie Tipster Hannah Smith got her horrible pongy body spray out and squirted the stuff all over my clothes so mummy Comps Minion started asking all sorts of really embarrassing questions about girl friends and 'bringing her home for tea'. Squirr.

Anyway, I went into a major huff and locked myself in the broom cupboard for a day. But when I came out Graeme was very cross and told me that I had to apologise to all the readers of CRASH for my mistake. So I'm really sorry about the cock up last month (not really because it wasn't my mistake,

winge) and I hope no-one was too put out. Huff. Well, that's that over with and here are the details of the competition again.

Those very nice people at THE EDGE want to give away some prizes in honour of their new game, the official conversion of Konami's arcade machine, *Shao-Lin's Roads*. All you have to do is study the two pictures of Kung Fu fighters Ian Craig's drawn here, and spot as many differences between them as you can. Circle the differences in Picture B with your biro, fill in the entry form and whisk it off to **KUNG FU MINION, CRASH TOWERS, PO BOX 10, LUDLOW, SHROPSHIRE, SY8 1DB** making sure it arrives by 31st December.

The first all-correct entry pulled out of Graeme's special Martial Arts Doc Marten wins the sender a Kung Fu suit, just like the one in the piccy, together with a copy of a book which explains the mysteries of the ancient Shao-Lin temple. This mystical place of worship was maintained by monks who defend it against barbarian hordes — the book is packed with information on the temple itself and explains Shao-Lin Kung Fu. But there's more! The winner also gets the choice of one of the following EDGE programs which will be released between now and Christmas: *Shao-Lin's Road*, *Manta* a shoot 'em up, *Fairlight II* and *Artist II*.

Fifteen more winners collect a copy of the Shao-Lin's Temple book and the choice of one of the above products; then thirty five runners up get the chance to choose a game from the same list!

NAME

ADDRESS

..... **POST CODE**

IF I WIN, I'D LIKE TO HAVE THIS EDGE RELEASE (Tick One)

- Shao-Lin's Road Manta
 Fairlight II Artist II

Another GREAT GAME FROM CAPCOM

1942



elite

elite

Screen shots taken from various computer formats

Spectrum	Cassette	£7.95
Amstrad	Cassette	£8.95
Amstrad	Disc	£14.95
Commodore	Cassette	£9.95
Commodore	Disc	£14.95
C16	Cassette	£7.95

Mail Order, just send a cheque or postal order payable to Elite, or quote your Credit Card number.



Elite Systems Ltd.,
Anchor House, Anchor Road, Aldridge,
Walsall, West Midlands, WS9 8PW.
Telephone: (0922) 59165.
Telex: 336130 ELITE.G. Fax: (0922) 64735

From the authors of
"Commando" and
"Ghost 'n' Goblins"
comes another great
Coin-Op classic
"1942"

The very best Elite Titles are
available at selected branches of:

- WHSMITH, Tandy
- John Menzies



On route for your SPECTRUM...

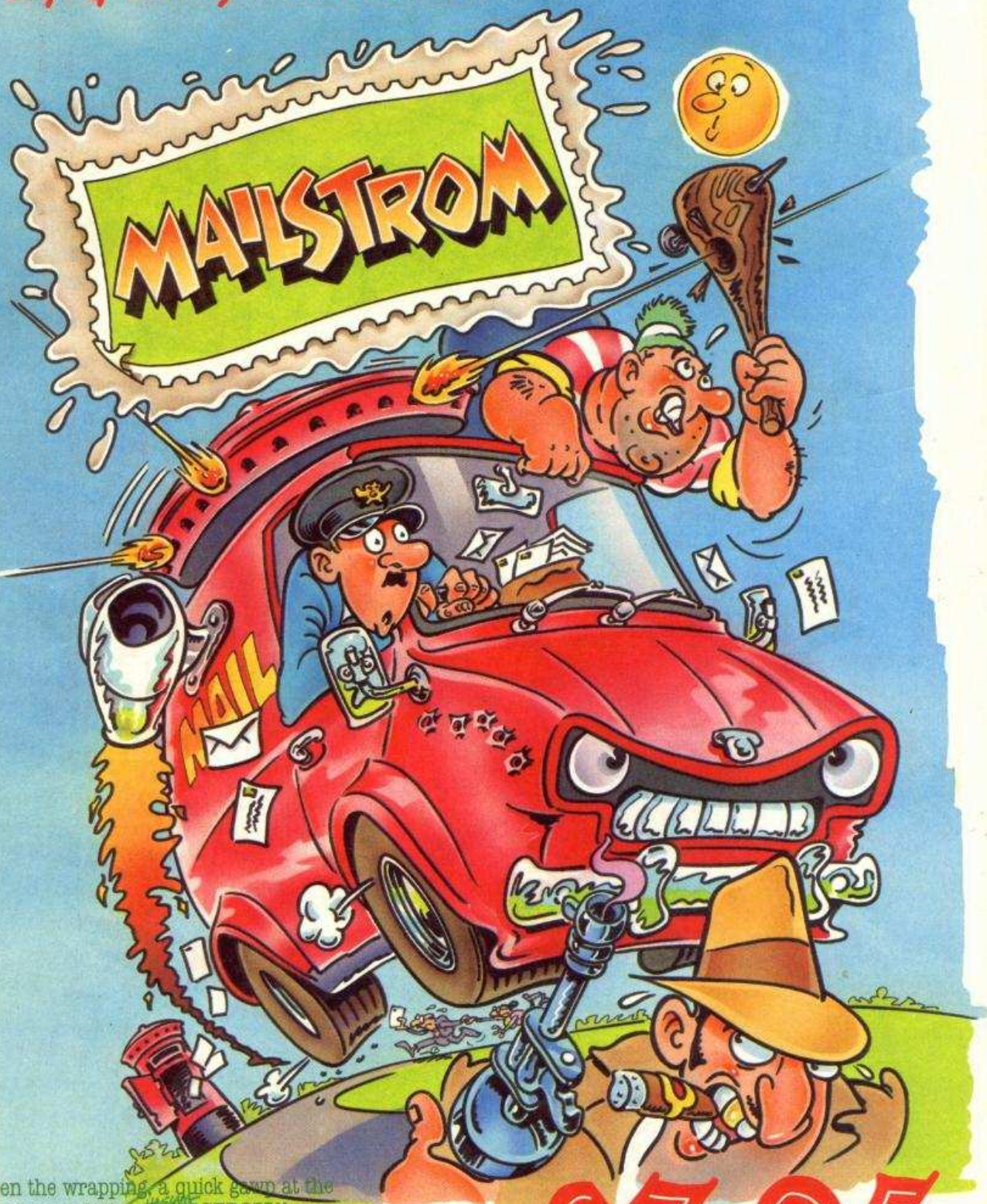

Tear open the wrapping, a quick gaze at the liner, load-up and it's... **MAILSTROM!!** Remember when you were, or still are!, a punky paper boy with a dream of slinging a motor on your bike? Well now your a real mean mail man and you've got a terrifying truck with an explosive delivery! Your the only mail man left on earth and there are plenty of baddies who are determined to make this your last post! So pack your punches and don't forget... **the post must get through!**

£7.95

ocean

Ocean Software · 6 Central Street · Manchester · M2 5NS
Telephone: 061 832 6633 · Telex: 669977 Oceans G

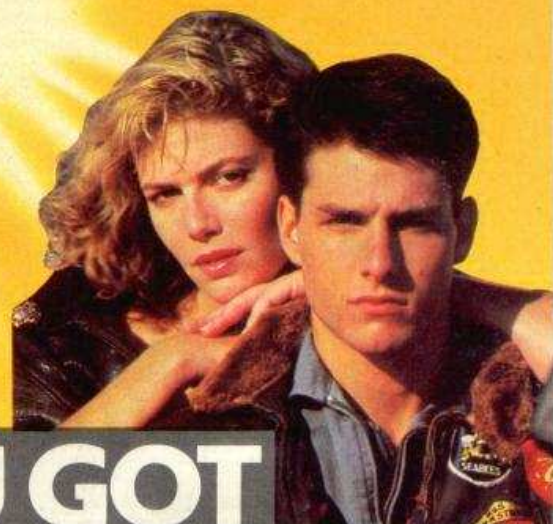

**HAVE YOU GOT
WHAT IT TAKES TO BE A**

TOP GUN

TM

Top Gun puts you in the fighter pilot's seat of an F-14 Tomcat.

Vector graphics and a split screen allow 1 or 2 players to play head to head, or against the computer.

Your armaments in this nerve tingling aerial duel are heat seeking missiles and a 20mm rapid fire cannon. Can you feel the force! Top Gun mavericks! Enter the danger zone.

£7.95
SPECTRUM



£8.95
AMSTRAD/COMMODORE

Ocean Software Ltd., 6 Central Street, Manchester M2 5NS. Telephone: 061-832 6633. Telex: 669977 OCEAN G.

Ocean Software: Distributed in France by Ocean France. Telephone: 93-42-7144. Distributed in Germany by Rushware. Telephone: 2101-70040.

TM DESIGNATES TRADEMARK OF PARAMOUNT PICTURES CORPORATION and used by OCEAN SOFTWARE, LTD. under authorization.

CRASH COURSE



by Rosetta McLeod



LINGUA FRANCA

Recently I attended a national conference on 'The Micro and the Language Specialist' which attracted delegates not only from Britain but also from other European countries. The conference certainly brought home to me the significant role that the microcomputer is now playing in the teaching of languages, from helping young children to read, to encouraging older pupils and adults to master a foreign language.

This month, then, Crash Course looks at two publishing houses who have produced programs concerned with language development. The *English Language Tutors* from Options International aim to teach the basics of the language to primary school children with language difficulties. The author, Edward Ingram, has a degree in Psychology and has had a great deal of teaching experience with children suffering from profound language disorders, such as aphasia and autism. The programs have been thoroughly field-tested in schools.

The Options range also includes three foreign language tutors — French, Spanish and German — which have been designed to help beginners learn the languages and also to provide a revision aid for exam students. The programs cost £8.95 each and come with a detailed information booklet.

AVP Computing, too, whose programs featured in July's Crash Course, have also issued some interesting modern languages programs. I particularly enjoyed the *French Crosswords* program, and the *Dictation* package, combining the computer program with audio input, is a worthy study aid. These two programs cost £10.00 each, while the *Time* programs for French, German, or Spanish cost only £6.00 each. For further information about any of these programs contact:

Options International, North Street Farm Workshops, Stoke-Sub-Hamdon, Somerset TA14 6QR

AVP Computing, Hocker Hill House, Chepstow, NP6 5ER

BASIC VOCABULARY

Basic Vocabulary provides the solid core of nouns which are used in the other English Language Tutors.

The menu offers three choices, Describe, Spell and Command, together with seven possible sections. The words in each section are given in the accompanying booklet, and each section contains five groups of four words, such as 'table, chair, bed, stool' and 'plate, jar, saucer, dish'.

If the Describe option is selected, the screen display shows pictures of four objects in different colours (red, blue, green, yellow and pink are used), and you must type in the correct phase which will describe the highlighted picture. This might be 'a blue table' or 'a pink chair'. In this first option, the noun is spelt out above each picture, then if Spell is selected, the name of the highlighted object alone has to be typed in. The final option allows you to command the computer to 'colour the fish pink' and so on.

As with the other three English Language Tutors, this program uses colour coding as an indication of part of speech. White-green-red, for instance, would mean that the computer is expecting a determiner, an adjective and a noun — 'a red car'.

This program is certainly very useful for teaching spelling, colour, and simple parts of speech, and the animated graphics provide a child with a good incentive to complete each section.

QUESTION WORDS

This program, which provides considerable practice in reading, aims to teach pupils to attend to question form.

The menu provides 14 options, graded in difficulty, and each section is presented in two parts, first with and then without the colour coded lines denoting the part of speech required. The interrogatives used are 'What?', 'Which?' and 'Where?' and you have to identify and name the various objects pictured on the screen, or type in the colour of an object, or where it is in the picture.

It is possible to use the program with or without penalties for incorrect answers, and the teacher can select the number of errors allowed before penalties are incurred. As with the other programs in the series, the screen display has been sensibly thought out to enhance the learning process.

CATEGORY NAMES

The object of this program is to teach an appreciation of group nouns or category names. Some of the categories covered include fruits, vegetables, crockery and clothing.

The program is based around four screen displays each dealing with a set of group nouns, and after the choice of screen has been made, the menu asks for a selection of tasks such as answering questions like 'What's the (noun)?'. For this task, four group names are given at the top of the screen, and under these, twelve objects. One of the objects is highlighted, and the question of which group it belongs to is posed.

When this has been mastered, two objects are highlighted, and this time the question 'Which is the (group noun)?' must be answered. The next series of questions

demand that the answer be given in the plural form, and it is also possible to choose to answer a random selection of questions.

This is all very well thought-out and carefully structured, and the attractive use of graphics and colour is extremely effective.

COMMENTS

Control keys: all the letter keys are used
Keyboard play: responsive
Graphics: very good
Use of colour: bright and attractive
General rating: a very carefully thought-out series of programs which would be particularly useful for children with learning difficulties

The opening menu from the Category Names program in Options' English Language Tutor program





PREPOSITIONS

Prepositions can pose quite a problem for many young children and this program sets out to teach not only the meaning, but also the spelling, of the commonly used prepositions. Some of the sections dealing with prepositions of movement — such as into, onto, to and from — feature animated

graphics to make the meaning clear.

A nice touch is that after every second section has been completed, a revision section is presented and if persistent errors occur, you are sent back to the relevant practice section.

The screen graphics are especially good in this program, and the careful structure which has been adopted is extremely impressive.

LANGUAGE VOCABULARIES

ENGLISH-FRENCH ENGLISH-GERMAN ENGLISH-SPANISH

Each of these three programs in the Language Vocabularies range contains more than 900 words with their English equivalents. The menu offers a choice of several sections based on parts of speech — nouns, verbs, adjectives, adverbs, conjunctions and prepositions — and you have the option of having words displayed in English or in the foreign language. If a ZX printer is attached, the correct forms of any incorrectly translated words can be printed out.

At the top of the screen, the computer displays the number of correct answers given in the appropriate section, together with the number of attempts and the total number of words in the section. For an answer to be accepted as correct, it has to be exact: for example, if the German verb *schauen* is translated as *look* it is marked wrong as the whole infinitive to *look* is required. Similarly, the translation of *das Wohnzimmer* must be *living room*, and *living room* or even *the living room* is

not acceptable. Accented letters are represented by graphics characters, and a list of these is obtained by typing 'q'.

Although these programs do offer quite a large database of vocabulary words, no attempt is made to make learning enjoyable, or to use the words in any sort of context. As a result then, it seems that the packages would only be of use to a very serious student, and the target audience of 'children from 10 years through to CSE and O Level student' would not find the programs interesting or entertaining enough to provide any motivation for learning.

COMMENTS

Control keys: English or foreign language words typed in as normal, with the Graphics mode for accented letters

Keyboard play: good

Graphics: none

Use of colour: black, white and grey only

General ratings: useful for the serious student, but unlikely to have much appeal for school pupils.

FRENCH CROSSWORDS

Doing crosswords is an enjoyable and painless way of extending your vocabulary, and for those learning French, this program should supply a useful language opportunity. Full instructions are given in French on the screen, and in English in the accompanying notes.

First you are given a choice of 15 crosswords, though these are not graded according to level of difficulty, and when the selection has been made, a grid appears on the screen surrounded by an alphanumeric border. You have to enter the co-ordinates of the first square of the word for which you want a clue, together with the letter H for 'horizontalement' (across) or V for 'verticalement' (down). You can then type in your answer which, if correct, will be displayed in its position on the grid. If wrong, you can keep trying, or ask for the clue for another word by pressing

0. You can also choose to see all the answers displayed on the grid by entering A, though you are advised to do this only after several genuine attempts to solve the crossword!

I thoroughly enjoyed this program and found that much of my long-forgotten French was coming back to me.

COMMENTS

Control keys: letter keys used as normal, though there is no facility for typing in accents

Keyboard play: good

Graphics: limited to the grid

Use of colour: adequate

General rating: fun for crossword addicts, this program is a good way of revising and extending vocabulary.

TIME FRENCH/GERMAN/SPANISH

These three programs on telling the time are designed both for classroom use and private study. When the program has loaded, a menu offers two options, Demonstration and Test. In Demonstration mode, the time is displayed on a clock with the appropriate words appearing below. By pressing H or M, you can advance the time in hours or minutes, and midday and midnight are indicated by flashing symbols at the corners of the clock face.

Having worked through this part of the program, you are then ready for the Test option, in which you have to enter in words the time shown on the clock in response to the question *Quelle heure est-il?/Wieviel Uhr ist es?/Que hora es?* Accented characters are obtained

by pressing the appropriate key in Graphic mode, for example 'e' on key E. If the correct answer is typed in, the country's flag shown at the side of the screen is hoisted higher on the flagpole, and if the answer is wrong, the correct version is displayed immediately below. At the end of the test, your score out of ten is given.

These are extremely simple little programs with no frills or gimmicks, but provide a helpful opportunity for learning to tell the time in the three languages.

COMMENTS

Control keys: letter keys to input the answers. Graphics mode enable accented characters to be obtained very easily

Keyboard play: fast

Graphics: clear clock face

Use of colour: not over-used

General rating: useful little programs, sensibly constructed.

If you've got the time.....AVP can tell you what it is in German

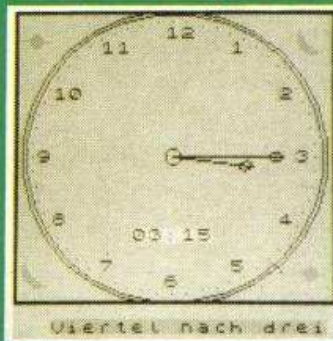

FRENCH DICTATION

This package contains both the computer program and a recording by a native speaker of the 10 dictation passages which the student can attempt.

A menu of options appears on the screen, and to begin with, only the first option 'Enter student version' can be selected. On choosing this, you are then instructed to listen to the passage of your choice all the way through to gain an understanding of its whole meaning. Then you must listen to it phrase by phrase and type in what you hear. The last stage is to rewind the tape and listen for a third time, in order to make any final changes to the version now on the screen.

Obviously, for this program to be useful, meticulous accuracy in following the instructions is required and the booklet draws attention to ways in which the program can produce misleading results if used incorrectly. For instance, a word omitted completely will not be detected as an error.

When the full dictation has been entered, the menu reappears and you can then choose to see your errors and view the master version for comparison. If a ZX Printer is

attached, a print-out of both the master and the student version can be obtained. The master versions are also provided in the booklet.

No attempt is made in this program to quantify your errors because, as in an exam, the mark awarded is not arrived at solely by counting the number of misspelt words. It is hoped that, by viewing all your errors and studying the master versions, you will be able to understand the mistakes you have made.

I found this program to be a very sensible way of preparing for the requirements of O Level dictation with the audio element being very clear and easy to follow.

COMMENTS

Control keys: phrases typed in as normal, with characters obtained through the Graphics mode

Keyboard play: good

Graphics: none

Use of colour: limited

General rating: a very useful study aid both in the home and at school.

GENESIS

THE BIRTH OF A GAME

BIRTH OF A PAINTING...

NOT QUITE ACCORDING TO PLAN "A"

By the time you read this, the program should... Well, you've heard that before a few times and nothing has actually materialised. Unfortunately, this is the case with the GENESIS project: *Kat-Trap* is going to be a little late.

According to Plan A, the game should really have been completed in time for review in this issue of the magazine, but with fast approaching printers' deadlines looming on the horizon at CRASH Towers, Graham Stafford was beavering away at DESIGN DESIGN's HQ trying to complete the game in time for us to review it.

He missed our deadline, and we'll have to book a slot in the Christmas Special. The project is a couple of weeks behind schedule at the moment: "Considering the industry standard, that's quite good really," Graham points out, "but the position is far from ideal."

"The game is at the stage where all the collisions, sprite paths and so on are in there but I'm still working on some of the backgrounds and animation. One of the main problems, apart from the general pre-Christmas rush here at DESIGN DESIGN has been the fact that Jon has provided me with an awful lot of excellent graphics."

"He's really got the hang of our design utility, and has been turning out some very detailed, high-quality animation sequences. In all, I've had about 50 or 60K of graphics, and as I explained a while ago, there simply isn't that much room

in the Spectrum. The difficult part has been in selecting which bits to leave out... for instance, Jon sent me fifteen or twenty frames of animation for the Ice Men, who run about and melt when they're hit, and I've had to pare that down to six frames. The game runs fast enough for the difference to be hardly noticeable, but it all takes time."

Mark Strachan, of DOMARK has nothing to hide: "We've been through this mill before on projects, where things don't quite happen to plan," he explains. "We've had delays on other programs owing to unforeseen problems on the programming end, and the Number One thing on our mind is always the customer. We have to satisfy our customers — we could probably release an early version of a game that's running late and avoid or minimise the delay but if we do that then it's likely that our customer won't continue to be a customer."

"*Kat-Trap* will benefit finally. It'll be worth waiting for. Sometimes people in this industry use it as an excuse for delay... but it is the case with *Kat-Trap*."

So there you have it. By the time you read this, *Kat-Trap* should be at CRASH Towers and the review for the Christmas Special written — providing there are no major disasters between now and the middle of November when the last bits of the Christmas Special have to be at our printers....

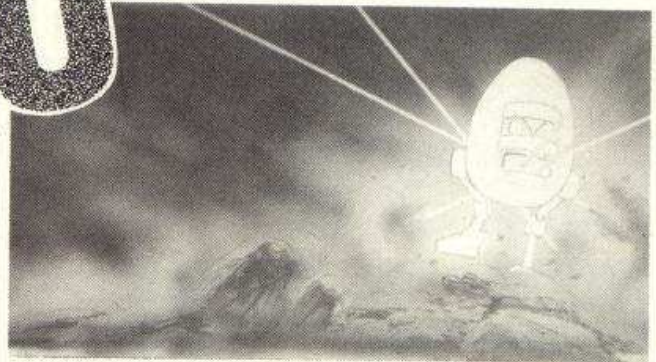

The first stage

As we explained last month, Jon Eggeilton and Oli Frey spent an afternoon together discussing the artwork for the *Kat-Trap* inlay and advertisement. Soon after Jon left Ludlow for Milton Keynes, Oli set to and began work.

"M.T.-ED is a very appealing character, cute in fact," Oli said before beginning work, "and the difficulty is going to be in presenting him to the best advantage in a painting that is suitable for an advertisement. He looks much better from the side view, but the theories of advertising suggest that the central character should move 'out' of the page, which means drawing a front view."

With the basic brief from DOMARK which governs the area of the A4 magazine page that will be used for logos, prices and advertising blurbs, Oli set to work.

"I decided to paint a larger picture than was strictly necessary," Oli explained, "with a large area to the left which has very little in it. The idea is, that the whole painting can be used as a wrap-around on the cassette inlay and could even be used as the basis of a double-page spread advertisement. As the left hand side doesn't have much happening in it, screenshots, bar-codes and other information can easily be overlaid by printers if DOMARK want to use the painting in that way."

The outcome of Oli's work, in combination with DOMARK's advertising copy, can be seen on page 137 of this issue.

Oli recorded progress as he went along, pausing to photograph the stages in the creation of the finished work....

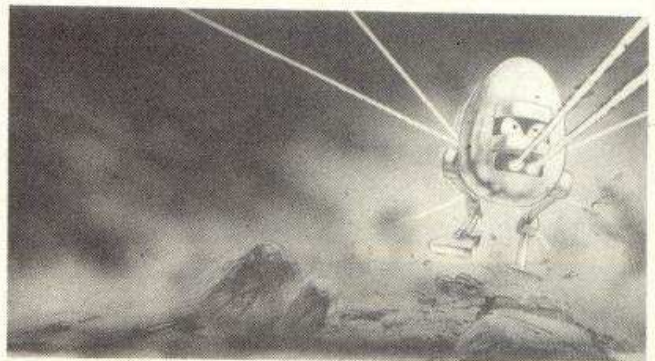

The fine brushwork begins. The masking film has been removed from M.T.-ED and work starts on giving him that metallic sheen...

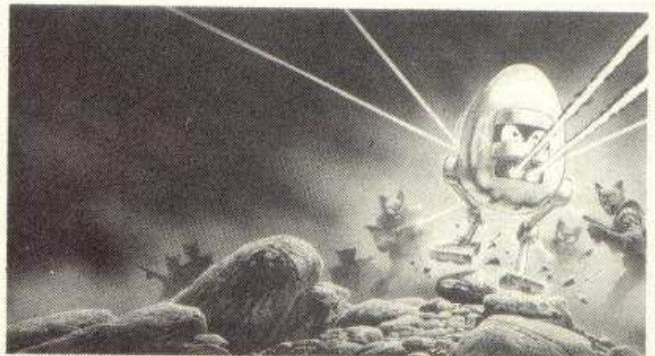

The finished painting. Detail has been added, still by brush, to the Kat-men in the background and to the rocks in the foreground



The logo for *Kat-Trap* was painted separately, developing on a lettering style that Mr Eggeilton created specially. It's easier to produce the logo on its own, because it can be dropped in on the painting wherever the designer wants — and it's more than likely to be used in several different places...

URIDIUM

NOW AVAILABLE FOR SPECTRUM



TURN ON TO URIDIUM THE ARCADE SPACE COMBAT GAME

Feel your adrenalin pulse as you throw your Manta fighter through its heart-stopping sequence of dives, loops and spins. Thunderous rocketry and shattering canon shells batter your senses. Screaming enemy fighters fracture your nerves. Cool crisis control rips you through the mobile and surface defences of the alien Super-Dreadnoughts to the confrontation with Uridium itself.

Uridium... the Spectrum version of the Commodore mega-hit by Andrew Braybrook. Programmed by Dominic Robinson.

For Spectrum Cassette £8.95

For Mail Order send a cheque/P.O. to Hewson Consultants Ltd. Order by Credit Card sending your Access/Barclaycard number and a specimen signature. Don't forget to enclose your name and address

As part of our continuing development of innovative software we are always happy to evaluate software sent to us with a view to publication

FREE GIFT
with every purchase

Offer closes 31st December



HEWSON

56b Milton Trading Estate, Milton, Abingdon, Oxon. OX14 4RX

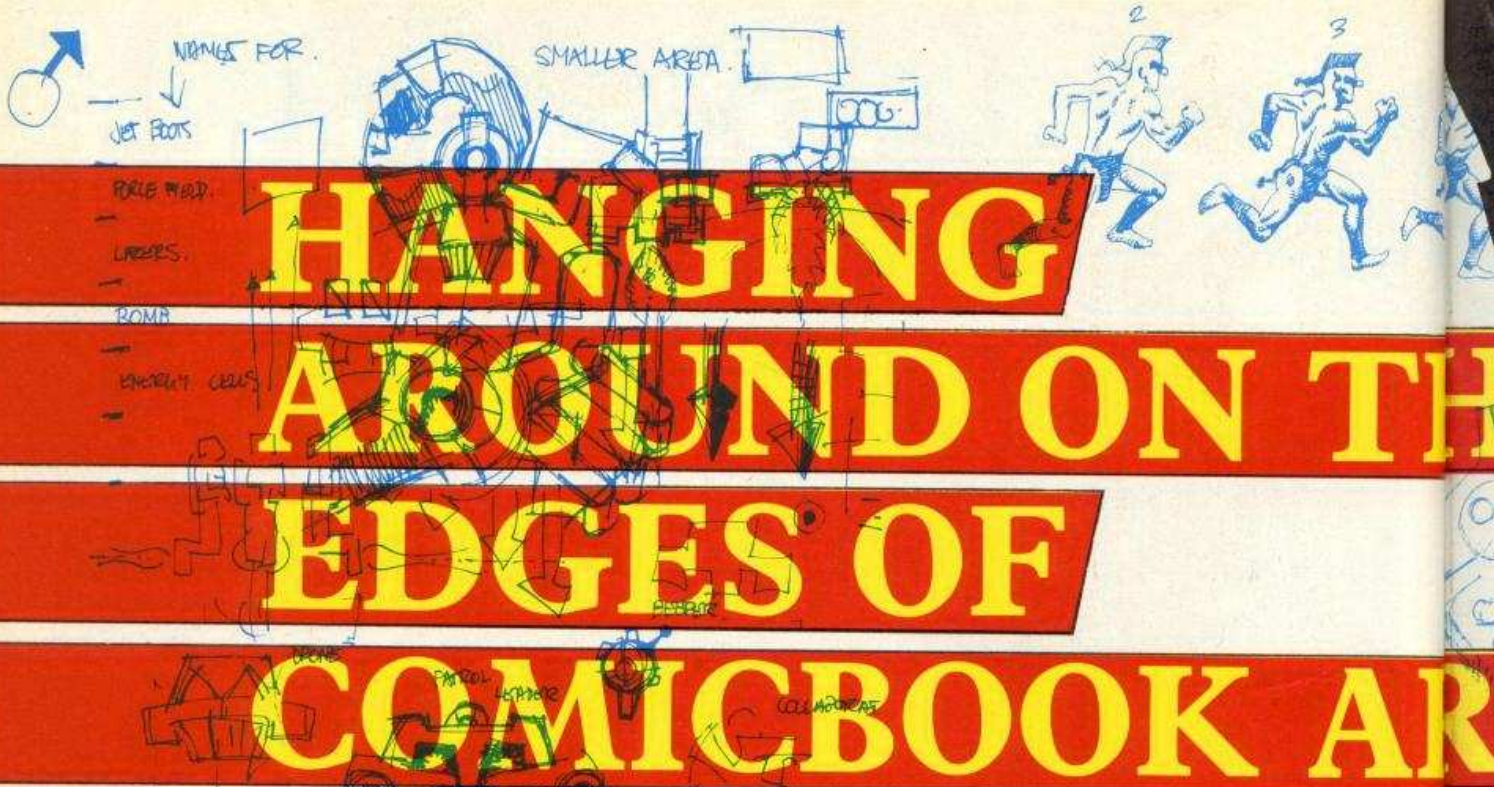

HANGING AROUND ON THE EDGES OF COMICBOOK ART

Ever wanted to write a computer program? Does hex code and assembler make you see red? Well, perhaps all is not lost. Now it seems a new breed of writer has entered the arena equipped with nothing more than a set of Rotring pens and a headful of ideas. Lee Paddon talks to DAN MALONE, resident artist at PALACE SOFTWARE and, in between being shown the



'Disappearing Chin' party trick, learns why hex and machine code are still very much a mystery to Dan . . .

When Dan Malone left Ipswich College of Art last year, possibly the thing furthest from his mind was writing a computer game. "I wanted to draw comic strips. I'd always admired magazines like *2000AD* and the *Marvel* comics. So I went and pestered them, but there was nothing doing.

"Obviously it's a very competitive line of work, and when you don't have a track record, it's hard to break in. I did do some work for *Knock About Comics*, which was sort of underground — they did things like *Fat Freddy's Cat*, with *Hunt Emerson*, who's a well respected artist. But with them, it was a case of 'oh we'll pay you if we've got any money left over at the end of the month.'

"Going to Ipswich was a bit of a waste of time, but I suppose it did one thing — it gave me a portfolio of drawings to show around and one of the tutors was really helpful. In fact, she pointed out the advert in *Campaign* which lead to this job".

That advert was placed by **Pete Stone** at **PALACE SOFTWARE**, and simply said '2000AD style artist wanted — no previous experience with computers needed.' "That was just as well, I'd never touched a home computer before. I'd seen a few machines in the arcades, but to me home computers meant little blobs flickering around a screen - I couldn't think what a designer was meant to do there."

But Dan rapidly discovered that things had moved on a bit since the early days, and was soon hard at work designing sprites for *Cauldron* on the Amstrad, which was nearing completion at the time. This just involved using a sprite designer on the Commodore. "It was a pretty bad program. You could only draw in one colour at a time, so the only time you could see what the sprite was going to look like was when you had the program running. Pretty hopeless. For *Antiriad*, **Stanley Schembri**, one of **PALACE's** programmers, wrote a far better art utility which allows you to have the whole sprite on the screen and animate it."

Meanwhile, the ideas for *Antiriad* were beginning to come together. Dan was given a few games to play to see what other people were doing and the sort of things that might be possible. *Cauldron* and *Sorcery* were two games that caught his eye as examples of good graphics. Dan's interest in *2000AD* style comics led naturally to an arcade adventure style game with an overall quest. He wanted a mythical theme to the game with hi-tech overtones, and so the plot for a post-holocaust world where civilisation has come and gone began to evolve.

The first drawings Dan did were the movements for Tal, the Barbarian. Throwing rocks, crouching, running. After a while, screens started to come together. "Then we all sat round the office, bashing ideas around, so there's a little bit of

HE

RT



IDEA?

AS CHARACTER COLLECTS PIECES OF ARMOUR, THE MORE PIECES HE COLLECTS, THE LONGER HE CAN GO INTO MODE @.

ONCE HE HAS COLLECTED 1 PIECE, HE CAN GO INTO MODE @ FOR A SHORTER TIME AND WITH LESS STAMINA. BUT IT USES UP MORE OF HIS PERSONAL STAMINA.

EFFICIENCY + STAMINA TABLES

THE OBJECT OF THE GAME IS TO COLLECT THE FULL SUIT OF MICRO-GENERATORS. SO THE SUIT CAN BE ACTIVATED IN THE ROOM.



everyone in there. I suppose Stan actually started programming the Commodore

version in July.”

Once the programmers got involved, the real battles started. Originally, the suit was going to consist of several pieces, but all this animation was really eating away at the available memory, so compromises had to be made: “There we’d be, lumbering in with these great big ideas that were totally impossible, but then again, it really pushed the programmers to try and come up with ways of doing things.”

But there were positive contributions as well. The programmers came up with the notion of ‘ressing in’ and out of the suit — the flashing combination of Tal and Suit when he gets in and out of it — and things like the teleport. But the programmers didn’t take over, Dan was still very much involved. “We had a program where I could alter backgrounds and then test them. If I thought a screen was too easy I could move a sprite a little, and then try it out again. I could move the position of meannies and the way they moved.”

“The game’s playability came about by trial and error. You design a route through the game and then stick in lots of red herrings. But obviously it is completely impossible to gauge whether you’ve succeeded, so it was a profound relief when the Press started to look at the preview versions and liked what they saw. I remember we took it round a preview version on the Commodore to Tim Metcalfe at C&VG. He looked at it, and decided he’d seen enough and wrote the first review. It was then that we really knew we were on the home stretch”.

Having lived with it for so long, the story of the world of *Antiraid* started to evolve, and so came the idea for the comic which comes with the game, drawn by Dan. He has evolved a whole life history for each meanie: “Most of them are just mutants left over from the war which ended civilization. There was another race on the planet which collaborated with the aliens when they invaded. So, for being so nice, the aliens enslaved them and turned them into cyborgs, part man, part machine. You’ll meet them in the city blazing away with rather nasty machine guns. Mutated dragons in the volcano section have been paralysed, but their jaws still work, and as they move their jaws, sparks are generated, which light the gas seeping up through the vents, sending a sheet of flame across the cavern.”

Well, after the Amstrad version has been polished off, it’ll be back to the drawing board for Dan. So now you know how it’s done. All you need is a few good ideas, a talent for drawing, a team of tame programmers and the odd year of late nights and you too can be a programmer. So what are you waiting for?



HardBall!

by Accolade

SPECTRUM 48K/128K

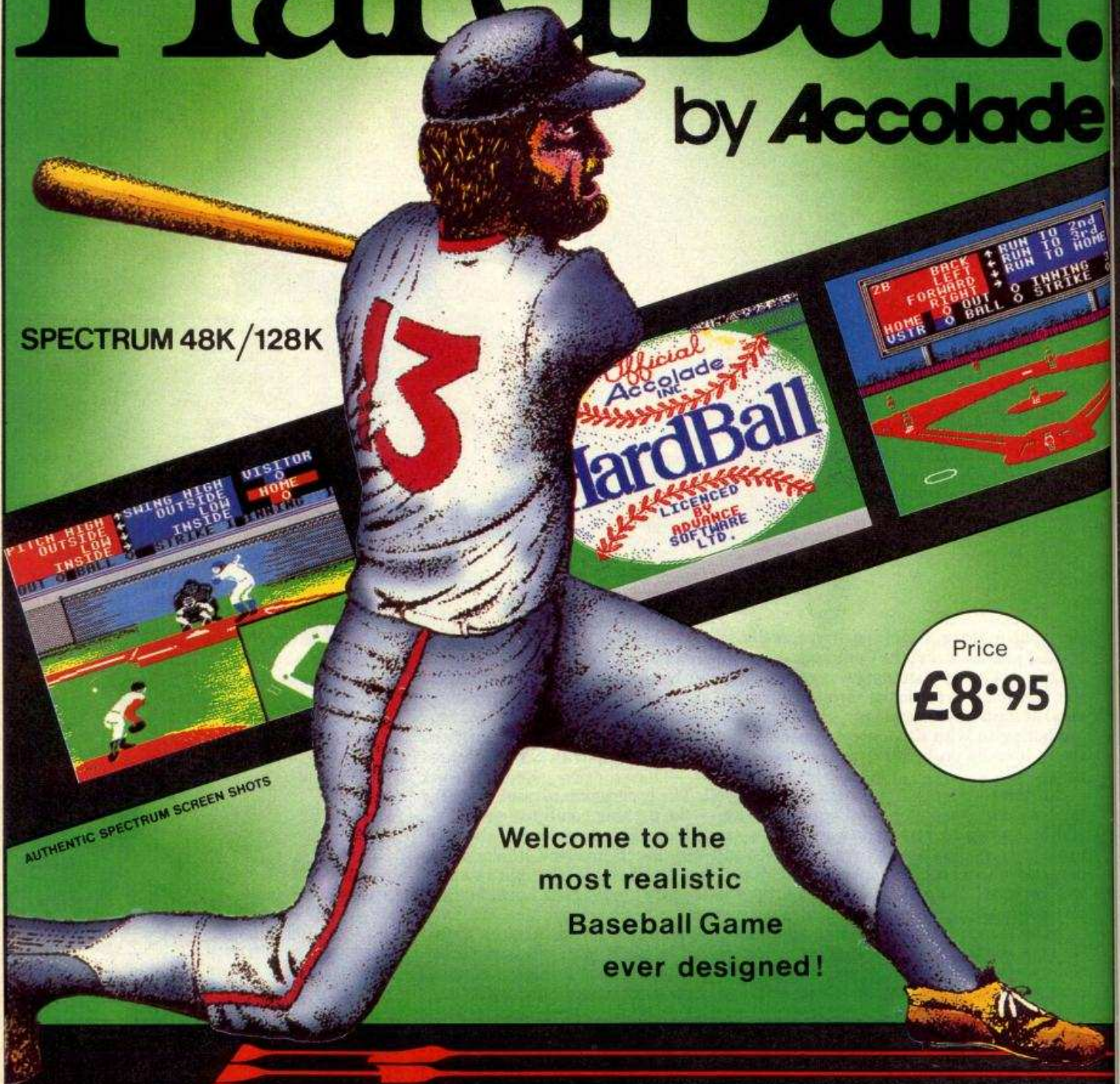

Price
£8.95

Welcome to the
most realistic
Baseball Game
ever designed!

SOFTWARE PROMOTIONS LIMITED

17 STAPLE TYE, HARLOW, ESSEX CM18 7LX TEL.(0279) 412441

DESIGN A FUTURISTIC CRASH SKIMMER

And win the very latest in techno
bop - A COMPACT DISC PLAYER

50 Copies of Academy, the
sequel to Tau Ceti, on offer!

**Crash
Competition**

It's really not very fair actually. Try as I might, I cannot please all of the people all of the time. Now that Graeme has been promoted to keep a watchful eye over all of the computer titles, there's hardly anywhere for me to sit down for a well earned kip without being rudely awakened by a size 10 executive Doc Marten. Sometimes I'll be rumaging in a bin trying to find some lost Girlie Tipster cosmetic and be thrown head first into it by a carefully measured blow from a patent leather Doc as Graeme tells me that I've got to run up to the Grovel Hill offices and incur the wrath of Aggie whilst I pick something up for him.

I mean, he's got a big company

car and it only takes him a minute to drive the couple of miles there and back. It takes me half an hour if I don't have too many mailsacks to carry. To think I once complained about carrying them up and down the stairs! Then as soon as I've got back, that young foggy Lee will ask me to run out and get some glue to repair his elbow pads, or some safety pins to try to hold together his aging Plus Fours. Once again, it's really not fair actually.

What is really needed is a form of transport for everybody in CRASH Towers - something that could cater for everyone's needs from the bottom, ie ME sulk, sulk, right up to the top. There'd have to be somewhere for Hannah to wash

her hair - which she does all the time - and somewhere for Ben to keep all his trendy clothes. Graeme needs somewhere to store his Gucci Executive Doc Martens, and room for a shoe shine kit (he's very particular since his elevation), and room for a tailor trying to keep Lee's rapidly disintegrating wardrobe in one piece. In fact YOU could design it for me.

It would be just like the improved *Tau Ceti II* where the wonderful Pete Cooke has included an option where you can design your own skimmer to cater for whichever of the sixteen missions you decide to undertake in the name of Galcorps. Our only mission here is to bring CRASH to you, dear readers.

so if you could customise a skimmer so that we can complete our monthly mission to bring you the best in the Spectrum Corps, then **CRL** will give the winner a fantastic Compact Disc player. Not everyone will be able to design a skimmer that CRASH can use, so fifty runners up will get a copy of *Tau Ceti II* with which to get in some practise.

Send your designs to us on A4 paper (that's 210mm x 310mm) to arrive here (once I've carried them all the way from Grovel Hill), by 31st of December and address them to **STARSHIP CRASH COMP, PO Box 10, Ludlow, Shropshire, SY8 1DB.**

NAME

ADDRESS

POST CODE

Fairlight

Chronicles of the Land of Fairlight
2. Trail of Darkness

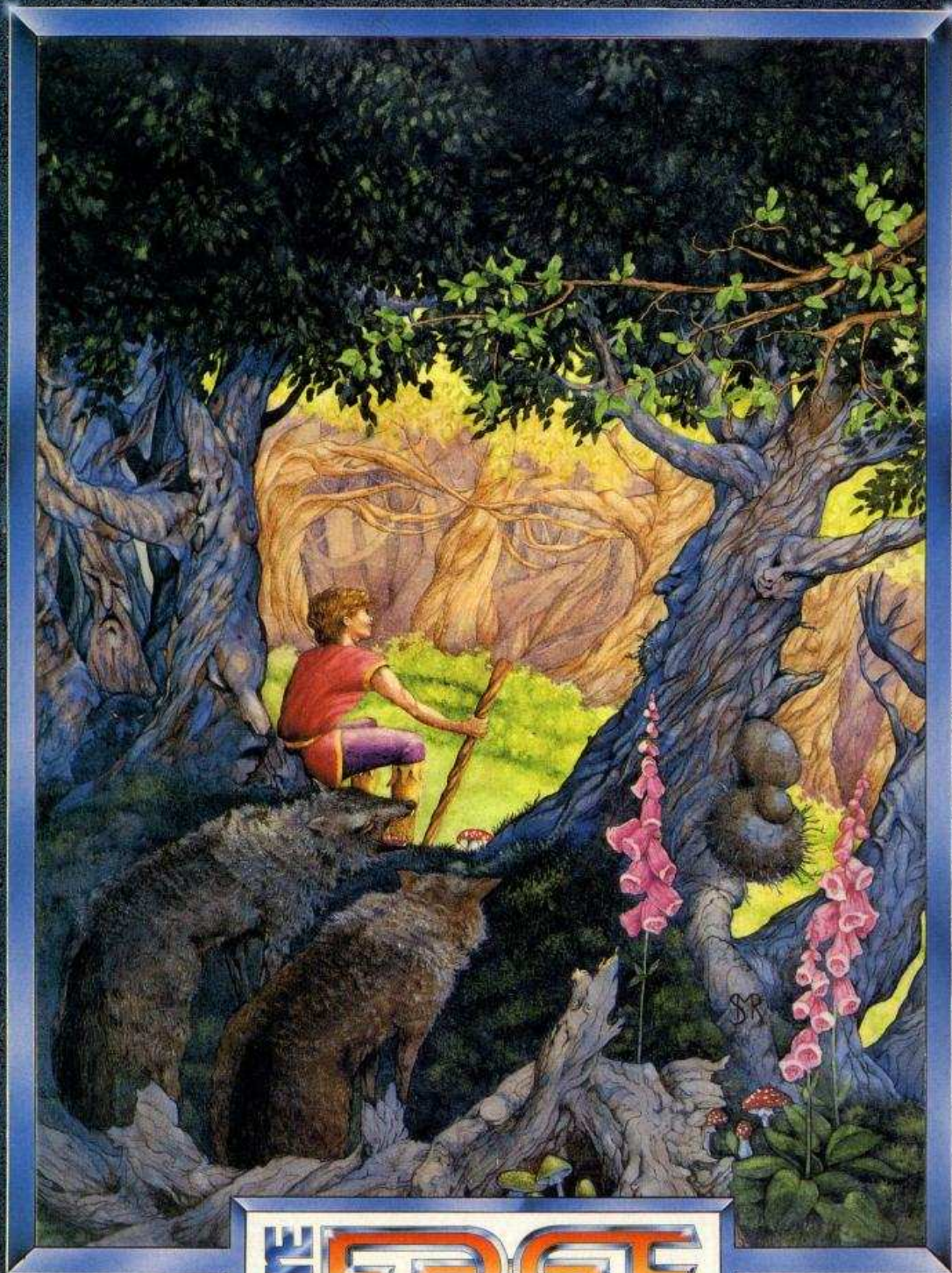

THE EDGE

**FAIRLIGHT II: the making of
software history... again**

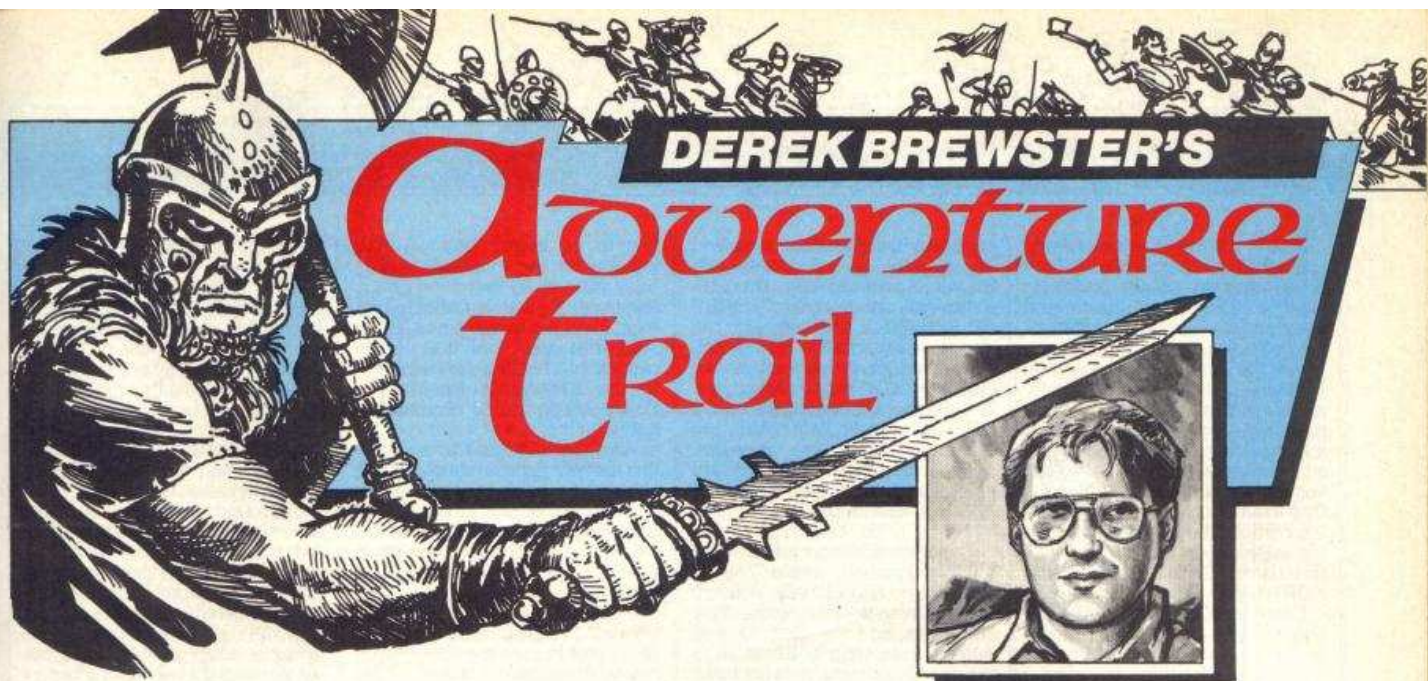

DEREK BREWSTER'S

Adventure Trail



very hectic time it has been getting this issue of The Trail out, but I think I've just about made it. Next month is the full-blown editorial which regulars will know comes along every bumper Christmas issue and I'm busy working on some of the ideas now. By the deadline I will have some words that reflect on the state of microcomputer games and how it relates to the broader picture.

This month I've reviewed *Twice Shy*, a mosaic game based on a book by Dick Francis, which, for a change, I have received before everyone else has even previewed it! The Bimbles are really a set of derivative Bombie, I mean Wombles, Demon of Darkness is quite a tough adventure which likes to fool around with the location descriptions, and *Prehistoric Adventure* is one of the best

packaged adventures I have ever seen for a game which at the time of writing is still mail-order only. It comes complete with a superb poster showing all those strange dinosaurs that walked the lands over 150 million years ago. I hope I've got these details correct as I'm writing this just after I've sent the whole works back to CRASH head office for screen shots, so I'm pulling all this information from memory, which is fickle at the best of times...

Also this month is a mention for two fanzines (as they call themselves), for adventure enthusiasts. One, *THE QUESTLINE CHRONICLES*, is basically a review magazine, while *ADVENTURE CONTACT* is more a forum aimed at improving adventure writing skills, a cause of which I wholeheartedly approve! I was most impressed with the standards of both, and perhaps one day I will get around to a proper survey of this whole underground world of publishing.

TWICE SHY

Producer: Mosaic
Price: £9.95
Authors: Ram Jam Corporation



Mosaic have a penchant for bringing out games based on books (remember *Adrian Mole* and *The Snow Queen*) and this release is no exception. *Twice Shy* is based on the novel of the same name by Dick Francis, a book which I must confess I have never heard of, but seeing as I only have the time to read the odd science fiction book these days, this is hardly surprising. How much reading the book

will help you complete the game is not made clear but let's assume the following storyline is based on the book.



You take the part of physics teacher Jonathan Dery who comes into possession of some intriguing computer program tapes. As you try to discover their purpose and return them to the rightful owner you attract the attention of some of the shadier figures in the horse-racing world. It seems they'll stop at nothing to wrest the tapes from you...

Steering clear of the heavy mob, you may make it to the racecourse which is in fact a whole separate plaything located on side two of the tape. A series of successfully placed bets can see you taking a useful pile of money back into the adventure, resuming where you left off — alternatively, you might find yourself going back with a lot less than you started with. The

racecourse section can be loaded whenever it is met in the adventure and, if you're the sort who is addicted to gambling in this way, you can load the racing game on side two all by itself.

The mechanics of the adventure are most pleasing. In appearance, or perhaps more correctly in style, the game has a passing resemblance to *Terrors of Transtoss*, the last RAM JAM adventure release. The screen layout is imaginative and attractive, as has been the case with many of the top non-Quilled releases of the last few months. On to the picture frame: in the top half of the screen the left hand side shows the scene, while on the right is a horse racing mosaic (to remind you of the game's main theme).



Also in the top area is the static location description text which never changes at any particular location. Changes in objects and people's positions and behavior are reflected in the print lower down the screen in a very tidy fashion — the character set is very nicely redesigned. The input routine is so fast and slick it appears to be as effective as LEVEL 9's famous type-ahead, while the vocabulary is broad and friendly. One example gives an insight into the complexities which lie behind the seemingly innocuous theme of this game: SAY TO JANE "GO NORTH AND SHUT THE DOOR".

Conversation with other characters relies on their attitude to you at the time. You can attempt to improve relationships by offering advice, offering objects or by sim-

ply being friendly. I could only find one example of unfriendliness in the whole adventure and that was partly excusable when ANSWER TELEPHONE is confused with the television and ANSWER PHONE does the trick. In general, all the indicators of a finely tuned adventure are there, including the useful GET ALL and DROP ALL, an extremely informative EXAMINE command and multiple command entry using a comma, THEN, or AND as separators on the one input.

The television and phone lie in the first location, where there is much to do and explore. You see Sarah Derry who is presumably your wife, and the telephone is ringing. Answering it, Sarah takes the phone from you, puts her hand over the mouthpiece and motions

you to be quiet'. That's all the intrigue for the moment, so you busy yourself by switching on the television to watch Dallasty and examining the mantelpiece. But a little while later Sarah is in a state of shock and must go immediately to the Keithlys in Norwich — Donna has stolen someone's baby.

Who the Keithlys are, and why this Donna person should pinch someone's little offspring is unknown to me, and probably anyone else who hasn't read the book. No doubt though, as in any good yarn, all will make sense in due course.

Moving upstairs to the main bedroom, quite a list of items are given you free as it were, without having to make recourse to the EXAMINE command. The bullets

for an Enfield rifle rightly make you suspect you should have found such a rifle by this stage, while the canvas bag and exercise books should find some use further along the way. If you choose to, loading up the rifle is easily achieved here. There are quite a few further easy pickings upstairs, some with more obvious immediate uses than others. I'll leave this part of the game at the point where you will no doubt pause for a while...

The other side of the tape, the horse-racing game, is a tonic to all the brainwork of the adventure side where, on the face of it, all you have to do is plonk your money on any number of four horses and see how the race goes. However, the conscientious gambler, or those who consider every pound important, may wish to study the form of the horses in each race. This being a computer game, you might expect some formula to make itself felt after a few goes, but I found it hard to spot any consistencies so I suppose in that sense, this game mimics the real thing.

I began at Wintersthorpe Park with the offer of a full racing day of six events (you must see through all the events of a day — even if you lose everything on the first race). Noticeable are the names of races and horses (many of which ring bells if you are familiar with MOSAIC's previous releases), and some strange odds, like 16 to 9, and 17 to 5, which are presumably a mathematical tease designed to have you scratching your head to work out which are the most favourable.

I liked this racing simulation a lot. The graphics are very good, showing the four horses galloping across the field with a great variety of finishes — either with a horse coming from behind to win or perhaps two horses pulling away from the field in a neck and neck finish. Many permutations are seen in a meeting. It is most intriguing to study form before or after a race, trying to analyse the relationships between the going (hard, soft, heavy and so on), the weight carried by each horse, its preferred distance, and its recent form presented in a history table. Attempting correlations with all these variables can take some time!

I think *Twice Shy* is ably professional product from the MOSAIC team, and the RAM JAM CORPS have played their part in providing a most slick and playable program. Everything about the game, from instructions to completion, is thoroughly entertaining.

Difficulty: easy to get into
Graphics: attractive
Presentation: very neat
Input facility: beyond verb/noun with speech
Response: type-ahead allowed in an amazingly fast routine
General rating: polished to a 'tee'

Atmosphere	85%
Vocabulary	91%
Logic	90%
Addictive quality	89%
Overall	90%

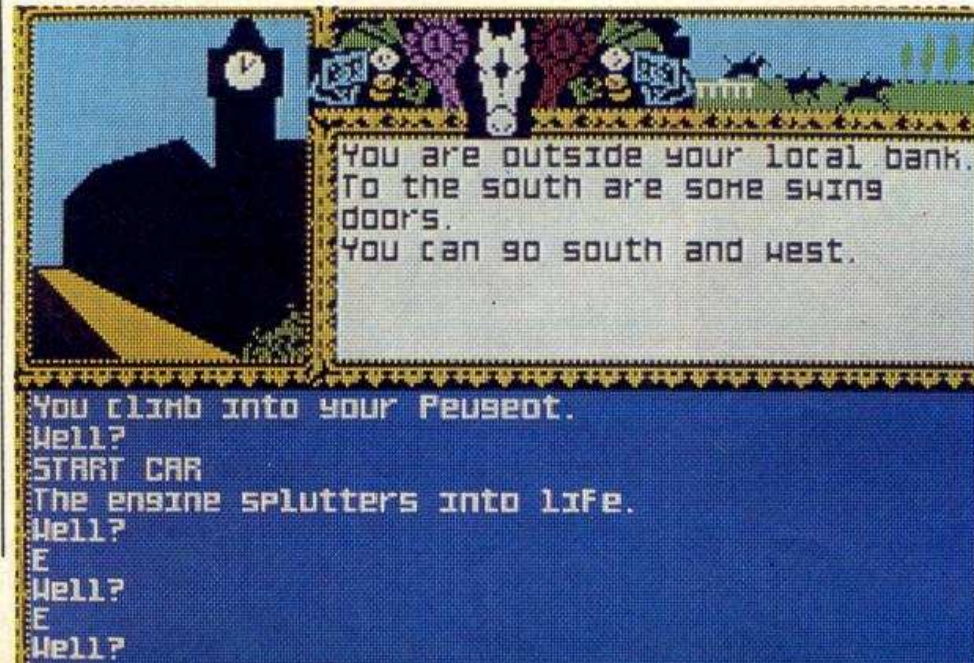
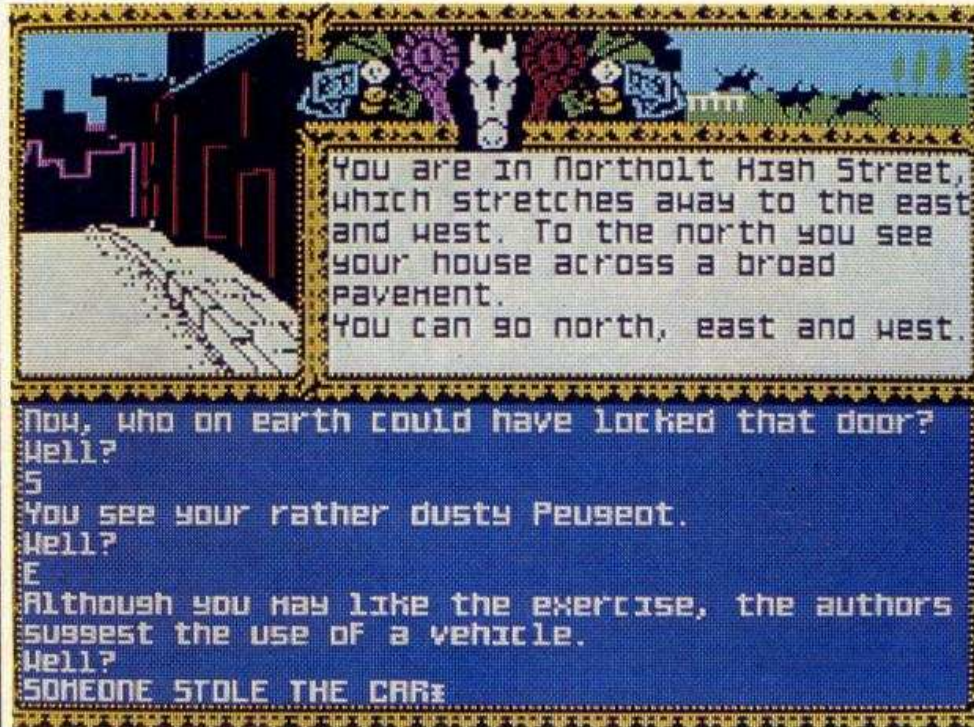



PREHISTORIC ADVENTURE

Producer: **Crusader**
Price: **£9.95**

This adventure represents a return to old values when size, tremendous involvement on behalf of the player, and a cracking set of intricate puzzles ruled the day. An enormous amount of effort has gone into this project, far more than is normal for a new software house, whose motto is 'Adventures for Connoisseurs'. The cover and instructions are of a very professional standard, and when I saw the quality of the poster, depicting all manner of prehistoric nasties and not-so-nasties, I was most surprised to see it was copyright of Crusader and not the Natural History Museum! All of the creatures you are likely to meet are presented in a most informative fashion, with the poster dominated by the largest group of animals ever to wander the face of the Earth - the Dinosaurs.

These developed into beings of widely varying shapes and sizes during the Jurassic Period, 150 million years ago. Some are instantly recognizable: the Stegosaurus with its rows of plates along the length of its back, now thought to be an adaptation for controlling its body temperature, Tyrannosaurus Rex, a scavenger with tiny forelimbs, and Brachiosaurus, the largest of the whole bunch, thought to have wallowed around in swamps. It's a nice poster - it really is.

In the sensibility stakes the storyline doesn't win any prizes for lucidity, but perhaps a complex game can be forgiven an involved introduction. You begin at Stonehenge, you being a chap named Ohio, listening to some old man tell you about the secret of eternal youth. Ignoring the fact that this man is old for a moment, you listen attentively while he informs you of this great elixir of life which bestows eternal youth (we'll have to assume his age has

crept up on him due to his supply of the elixir running dry!).

The man divulges the secret ingredients: a fruit which grows on a tall arrow-leaved tree found on but one island. This Amaranth fruit covers the island and is the staple diet of a bunch of renegades that should have died out ages ago - them very same dinosaurs as so nicely depicted on the poster. The reason for these creatures staying way over their allotted place in history is attributed to the same elixir qualities which keep men young. Getting to the island is no walk-over either, but there is some help in the form of the old man's map which, for reasons best kept to himself, he has secreted beneath a plain (a maze to you and me) by an underground stream (in other words when you find it, you'll know it).

As you might expect from a traditional adventure which resembles the classics of the past, this game is no walk-over and will take quite a concerted effort to complete. Traditional in its general feel perhaps, but in many details the game has quirks very much its own. First of these curios is its insistence on full word entry with no abbreviations, so commands even as long and common as INVENTORY must be spelled out. (The program does offer relief with some of the dinosaur names where shortened nicknames can be used, like Ally for Allosaurus). Keeping to the out and out eccentricities for a moment, a certain amount of imagination has gone into the location descriptions, but in a way which has locations seeming to change name, eg a pool of water is simply described as a spring on subsequent visits, not a totally distracting influence, but some cause a series of double checks to see if you are indeed in the right location shown by your map.

The game does feature a fast RAM SAVE but the quit routine can catch you on the hop if you haven't

saved first; there is no option to return to a new game, a previously saved position offering the only route back. The inconvenience is much lessened, though, by the authors kindly supplying the start position load immediately after the game on the tape. There seems to be a total lack of an EXAMINE command. Set against some of these eccentricities is the very useful input-error handling which can point out words the program doesn't understand and also supply hints or very direct prompts towards what the program might understand.

Lastly, the Crusader team provide a very good set of hint sheets which, far from just dumping the solutions in your lap, still make you work for your progress. Hints lead onto easier clues if needed, followed by the problem solutions for those who really are flummoxed. Even with these, on some occasions direct solutions are still left

to the adventurer.

Prehistoric is a most professional adventure game which is a much better bet than the reams of Quilled games on offer at the moment. Although expensive, the game is all machine code and sports many sophisticated features.

The game is available from Crusader at 18 Henley Wood Rd, Reading RG6 2EE.

Difficulty: difficult
Graphics: none
Presentation: minimal, redesigned character set
Input facility: verb/noun
Response: fast
General rating: solid, fascinating adventure

Atmosphere	84%
Vocabulary	76%
Logic	86%
Addictive quality	85%
Overall	84%

THE BIMBLES

Producer: **Intech**
Price: **£3**
Author: **John Matthews**

Here's a game which heralds its arrival as 'the game no-one's been waiting for', and luckily this kind of honest humour carries on throughout the proceedings. Theme-wise the program borrows much from the Wombles, a bunch of ecologically sound furry eccentrics who once inhabited a TV slot just before the BBC news.

This game is Quilled and mail-order only, but it is friendly, funny, and captivating in a barmy sort of way so I'll take you through the plot to see what you think of it.

It looks like these Bimbles are just as green as their more famous counterparts, as they are very worried at the new developments in Bombledon Park which threaten to destroy the local ecosystem - not to mention their own cosy burrows. Your task, as Fungo, is to find out who is digging up the place and to stop them before the next set of Yuppie apartments are laid out.

Much of the game's strength lies in its useful examine command, and in the option offered on conversing to the various odd-bods who inhabit the warren of burrows which is your home.

The graphics wouldn't win any art prizes (or perhaps they are so bad that these days they just might), but there is a good sense of colour - fairly simple but worth seeing nonetheless.

Mapping this game is quite straightforward as there are no magic wands continuously whizzing you from place to place, or any other such disorientating influences to contend with.

The first of the looney characters you meet is Great Uncle Buggeria who strains through his 36 pairs of spectacles to utter,

'Puss will get greasy if she is not sheltered from the rain' to which Fungo quite rightly retorts, 'Oh shut up you doddering old fool', whereupon the Great Uncle drops dead. Several other characters spout these cryptic nonesenses, but how much you will make of them I'm not sure. Perhaps the most intelligible one comes from Madame Croquet in her kitchen who supplies the puzzle, 'My basil pie should keep the cars off'.

On eating the pie you munch into a screwdriver, which doesn't say much for madame's cooking but does give you another useful object in a seemingly unending list. However, the program is generous, allowing you to carry ten objects at any one time. One of these, a physics book, is curious in that it can lead to an untimely instant death, and yet it cannot be dropped.

In one area we learn of a Bogeymon, who would seem aptly named as his heroes are Clive Sinclair and Graeme Kidd!

This is another example of the game's honest humour, which is really its overriding theme. As one final example I'll leave you with one of the comments you get on entering something it just can't understand: 'OK, OK, so again I bore you with the same message, but if I had enough memory left you wouldn't have this problem'.

Bimbles is available from 35 Lindale Av, Preston PR2 5LL.

Difficulty: easy to get into
Graphics: none worth mentioning
Presentation: colourful
Input facility: v/n
Response: Quill, very fast
General rating: funny

Atmosphere	82%
Vocabulary	81%
Logic	80%
Addictive quality	76%
Overall	79%



A Forest of Fascinating Fantasy

Enter the darkness and embark on a path of mystery and intrigue – terror and panic – stealth and cunning. A series of adventures and brain twisting journeys with a challenge and scenario to test the most formidable adventurer.

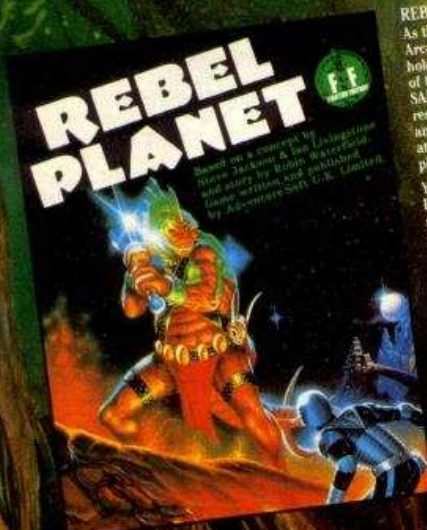

REBEL PLANET

As the might of the alien Arcadian Empire tightens its hold on our galaxy, the leaders of the secret Earth organisation, SAROS, gather their aleaxander resources into one last daring and foolhardy mission to strike at the heart of the invaders home planet.

YOU are their last hope. Equipped with a forbidden laser sword, your mission is to seek out the underground resistance and piece together the vital code you need to destroy the enemy. But time is running out and only YOU stand in the way of the Arcadians' complete domination of the galaxy.

CBM 64/128 \$9.95 \$14.95 Disk
Spectrum \$9.95 Spectrum Plus \$9.99
Amstrad \$9.95 \$14.95 Disk
BBC/Electron \$7.95

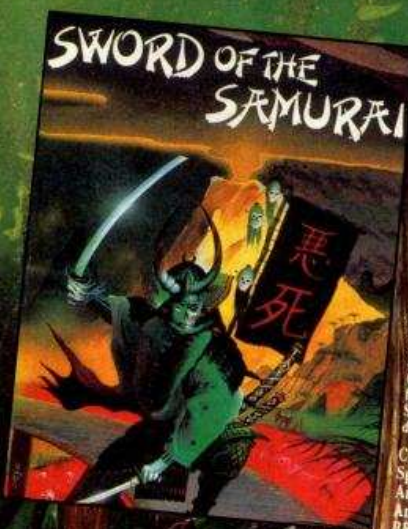

SWORD OF THE SAMURAI

The land of Hachiman is in grave danger. The Shogun's control is slipping. Bandits roam the land freely and barbarian invaders have begun to raid across the borders. All this because the Dai-Katana, the great sword, Singing Death, has been stolen from the Shogun.

YOU are the Shogun's champion, a young Samurai. Your mission is to recover this wondrous sword from Ikiru, the Master of Shadows, who holds it hidden deep in the Pit of Demons.

CBM 64/128 \$9.99 \$14.99 Disk
Spectrum \$8.99
Amstrad/Spectrum Plus \$9.99
Amstrad Disk \$14.99
BBC/Electron \$7.99 Text only



Isaac Asimov's

KAYLETH

The Zyronians were an advanced, pacifistic civilisation until the arrival of Kayleth and his obsessive craving for Chromazin.

Now, Kayleth rules the Zyron skies with awesome power, using an Atomic Bomber system to send down his powerful army of androids to enslave the Zyronians.

You, a loyal Zyronian, have avoided capture long enough to set into motion a plan to liberate your beloved planet. However, as you are about to discover, certain events have overtaken your well laid schemes!!!

CBM 64/128 \$9.99
Amstrad \$9.99
Spectrum 128K \$9.99
Spectrum 48K \$8.99
BBC/Electron \$9.95
IBM (Disk) \$19.99



Temple of Terror

The dark, twisted power of the young Malbordus is reaching its zenith. All he needs now is to retrieve the five dragon artefacts which have been hidden for centuries in the lost city of Vatos Skulls. Each day that passes brings him closer to them and only YOU can stop him! YOUR mission is to reach the lost city before Malbordus and destroy the treasures he seeks. But beware! Each step you take leads you closer to your doom...

CBM 64/128 \$9.99
\$14.99 Disk
Spectrum \$8.99
Amstrad-Spectrum Plus \$9.99
Amstrad Disk \$14.99
BBC/Electron \$7.99 Text only





DEMON FROM THE DARKSIDE

Producer: **Compass**
Price: **£2.50**
Author: **Jon Lemmon**

I like the title, the loading screen, and the intro tune, so let's have a look at the story behind this Quilled, Illustrated, Patched, Music Box'd, and Art Studio'd adventure, and, after all that, try and extract what sense we can.

Long ago, in the first age of the Ringmaster, a Falcon Staff fell into the hands of Drakon, the wizard of Valonia. Because he did not

to retrieve the Falcon Staff before the main army of demons cross the lake. Remember - Beware the raven.

So, it looks like your boss Ashmeard is staying right out of it while you, his apprentice, goes into this cave of Illindel to sort this Drakon chappie out. You begin at the entrance of a dark and shadowy cave, which must presumably be this cave of Illindel where you have to take on Drakon.

Cameron plays it safe and takes the sword of truth in this sticky situation

Just before entering the cave you are allowed one move to the north-east where you find yourself standing at the edge of a giant lake. Far in the distance across the lake you can see the large demon army of the storyline ranged against you. You can also see a red ruby and a dead body. Examining the ruby gives you no useful information, but as a rule the examine command in this adventure is very helpful, and indeed pivotal to your progress as seen here when you examine the body. Well, what do you know, it's old Ashmeard's body with a demon arrow sticking out of his chest. Now correct me if I'm wrong but



isn't he your gaffer, the one who's ruminating over the lands predicament, supposedly safe and warm away from all the aggro. Looks like he got his comeuppance in the end anyway.

Demon from the Darkside is a very good Quilled adventure sensibly priced. The look of the screens is most pleasing with good use of colour amongst its redesigned character set, and pictures which are atmospheric and imaginative. The game is available mail-order from Compass at 36 Globe Place, Norwich NR2 2SQ. Furthermore, if you are interested in a set of high quality, based and varnished scale lead miniatures which perfectly capture the characters in this very game a form will be sent with the game.

Difficulty: quite difficult in places
Graphics: reasonable and attractive
Presentation: good use of colour
Input facility: v/n
Response: fast, *Quill*
General rating: a cut above the average *Quill* release

Atmosphere	90%
Vocabulary	85%
Logic	78%
Addictive quality	84%
Overall	84%



destroy it, Drakon was turned to the darkside of the ancient magics of old. With his new found strength, he sent forth an army of shadow demons which conquered the lands and armies of Valonia. It was now that Drakon began to walk among men, and, with the Golden Mask of satan would go unrecognized amongst them until it was too late. Their souls would be taken in the dead of night and used to feed the giant skull of evil which stood in the Hall of Rats.

Still with me? - right then, I'll continue.

Ashmeard, the wizard of Dral, fought Drakon and seized the Golden Mask. Drakon, realising what had happened, let out an evil scream, leapt to his horse and rode into the cave of Illindel never to be seen again. A decade has passed since those evil times, but once more shadow demons walk the land and the dark force grows strong. Drakon is returning. . . .

You play the part of Morrack, apprentice to the wizard Ashmeard. While Ashmeard stays in Dral to buy time and to fight against the shadow demons, your task is to find and kill Drakon, and

Cameron resorts to bribery and corruption, so what's new.

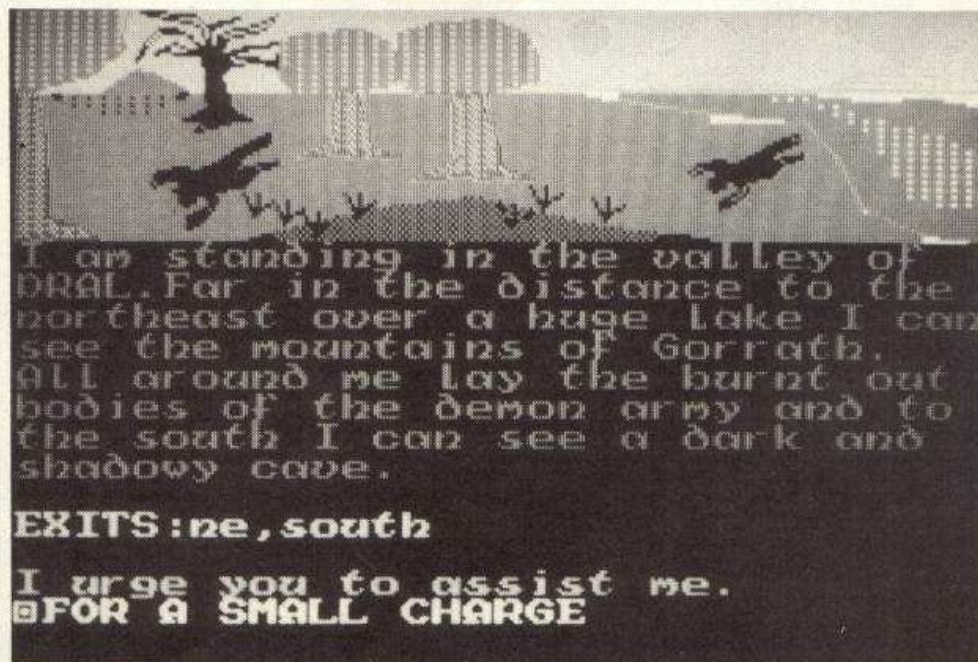



S.I.G.N.P.O.S.T.

MORE SINS

Dear Derek,
Here it comes - More, yes, more deadly sins.

1 You Have No Weapon

Quite common in most adventure games. Imagine you want to exit a room via a window. You type 'Smash window'. The response - 'You cannot attack the window, you have no weapon. Sometimes you cannot even attack people because you have no weapon (no fist either?).

2 Irrelevant Detail

Annoying items which you may find, but cannot open/use/etc. An example of this is in THE BOGGIT (excellent game apart from annoying details like this one). In the toilet there is a medicine cabinet, which, when examined, will be found to be welded shut with no apparent way of opening it. It was ages until I found that it had no use.

M J Nicholson, Merseyside

IF CONFUSED THEN... NEXT LETTER

Dear Derek,
After reading Mr Hawkin's letter on GAC, I decided to write in with a few comments of my own.

1 For the 'wear' command, I use the following conditions (all LOW priority):

IF (VERB 10) MESS 239 LIST WITH MESS 200 LIST 300 WAIT END

IF (NO 1 > 100 AND VERB 25 AND CARR NO 1) NO 1 TO 300 OKAY END

IF (300 IN NO 1 AND VERB 8) BRIN NO 1 OKAY END

IF (300 IN NO 1 AND VERB 26) BRIN NO 1 GET NO 1 OKAY END

When using these conditions, VERB 10 is 'INVENTORY', ROOM 300 is defined as '(SPACE)', and can be any numbered room (as long as '300' in the conditions is replaced by your chosen number), MESS 200 is 'and you are wearing', or its equivalent, and again can be any number you choose. Verbs 25 & 26 are 'wear' and 'remove/unwear' respectively and all

wearable objects must be numbered 101 or above.

I hope this advice helps Mr Hawkins and others with the same problem. I am also having problems, with the 'get/drop all' conditions, and could anyone who can solve them please write in to CRASH and help me. 3 True, Mr Hawkins, GAC is the best adventure utility for the Spectrum

Simon McGregor, London NW3

TRADITIONAL — SEEK WORLD DOMINATION

Dear Derek,
Having followed your adventure trail eagerly every month, I decided it was time to get my name in print! I have been a keen adventurer for well over 3 years and have lost count of my completed adventures. Please find enclosed the complete solution to AFTERSHOCK to aid your Signpost feature.

May I just add that I believe the arrival of spoof adventures ie BORED OF THE RINGS, VERY BIG CAVE, THE BOGGIT etc is providing a welcome change in the mainstream adventure scene. However, good as they are, and there is no doubt about that, I hope we do not get a deluge of this type of game at the expense of more traditional adventures. May I also make a plea to producers of icon-driven games - please make the icons distinct and at least faintly like the object they represent. It's an adventure in itself to discover what icons to use in a particular situation. This is a bad fault as in combat situations speed is of the essence.

Despite these minor comments, I think the adventure scene is very healthy at the moment and it is encouraging to see the adventure sections slowly expanding... One day we will achieve world domination!

M Kerr, W Sussex.

Thanks very much for the Aftershock tips, it is through the sterling work of adventurers like yourself that Signstumps can live long and prosper. I would agree with your comments on trad adventures - some recent releases have taken us afficianados back to the good old days when adventuring was a severe test of mental agility and ingenuity.

DB

BOTCH UP

Dear Derek,
From reading the Signstumps in the September issue, I've reached the conclusion that anyone could send in any solution that they care to make up for a game and you would happily print it without bothering to check whether it is the work of someone with only one paddle in the water or only toasted on one side etc. I'm referring to poor Mr Barnes who obviously went to a lot of trouble going through SHERLOCK only to find that the solution you had printed was wrong! There is a brilliant example of this in the very same Stumps as where poor old Mr B's problem is displayed.

Gareth Owen writes in with a list of hints and tips for JOURNEY'S END, which look at the very least dubious. He even admits that he hasn't finished it and quite frankly I'm not surprised because he is going about it in completely the wrong way. But you have printed these tips!! And anyone who follows them will never complete the game. I think you owe these people an apology. It's not as though there are that many. I could understand if you had to wade through thousands of solutions and publish them all, but you could perhaps take the trouble to check the few that you do print.

Here are some tried and tested tips for you on the excellent game JOURNEY'S END (which I have completed 3 or 4 times). In the dungeons at the start wait until you get about 450 gold pieces and then if you are doing badly start drinking the potions (which you are advised to leave by Gareth) as about 1 in 7 will give you freedom. When you are freed you are given the option to gamble. Do gamble but always bet on the 8 to 1 rat as there are only 5 rats and the winner is completely random, so you only have to win 1 in 8 times to make a profit. You always do if you use this system. You will soon have enough gold to see you through the entire game.

Gareth then goes on to say that the top priority when finding a magic tree is to ask it for the bridge position. Don't, if you do, then you and all your party will have 15 strength points deducted, a handicap from which you will find it extremely difficult, if not impossible, to recover. Instead, at the start location you should ask for the direction to the next tree; this will be either east or west. Go in the direction that you are told and you will soon come to another tree. At this tree if you were to ask for the direction to the next tree you would always be told North. So don't ask. Get a magic weapon, arrows, spells or food (in that order) and then go North to the next tree; this one will say when asked the direction either East or West. Go that way and the next tree you come to would (if asked) say North, and so on. Eventually the last tree to send you North will guide you directly to the bridge, so in effect, you can get a magic weapon etc at every second tree.



Don't ask a tree for strength in preference to food as you only get 2 strength points and you would get that anyway from food, and also, have the benefit of having just eaten.

Don't, as Garoth suggests, put the same number of men in the front line as your opponents, because when the opposition get close enough for hand to hand combat they will get a free hit at all of your men. Instead, if they have an even number then you should have an odd number and vice versa. If you do this then the free hits from the enemy will be aimed at the gaps between your men and cause no damage thus giving you a great advantage.

Carl Young, Nottingham

Hmmm, yes you have a point, but I think there's an aspect of this which is often lost on the bystander. Producing a magazine column month in, month out devours an enormous amount of time and effort for myself, and perhaps this is as good a point as any to answer the question which appears in so much of the mail I receive - Are you the same DB who writes games? And the simple answer is yes, I am indeed one and the same. I do not use this column as a vehicle to hype my own games because it just wouldn't seem right (I answer KENTILLA questions for one very obvious reason - I tend to have a rather good idea of what the problem might be!). I have been aware of the problem of dubious tips for some time and have rejected many, especially from the Stumps section for the very reason. However, the longer letter tips in Signpost, are rarely vetted as I assume anyone who has gone to the trouble of writing a whole letter must know something about the game. Also, I do not see inaccurate tipsters as great bogeymen because all they are doing is providing their own views on a game. You are free to take them or reject them. In all honesty, many adventures are far too complex, many with various solution pathways, to fully check and the tremendous number and variety produced over many year rules out an intimate knowledge of each.

DB

ZZZZ WAKES UP

Dear Sir,
With regard to the review of our adventure zzzz in the October issue I felt I had to write in with a couple of comments. Derek Brewster's review as a whole was quite favourable. He does make reference however to the input system, specifically DELETE.

The real problem here lies in the fact that the '0'/DELETE key is used by the joystick/cursor read routines as the FIRE key. To this end, pressing DELETE very often responds with 'fire' and inputs a joystick/icon routine. The problem was solved by programming the '1' key as a separate DELETE key. This, of course, should have been made clear on the cassette inlay, but Mastertronic omitted it. By using the '1' key, all delete problems should be overcome. I would be obliged if you could point this out to purchasers of the game in case they become as exasperated as Derek did.

Your comments on the fast auto-repeat are noted and we will make sure that future programs are corrected. I hope this letter will help your readers.

Clive Wilson, Fife

As a programmer myself, I have every sympathy with an author who is puzzled by companies' bias attitudes towards instructions.

DB

A BORING, STUPID WASTE OF MONEY

Dear Derek,
Over the last few months people have been writing to you praising a game written not too long ago called LORD OF THE RINGS. I am not here to grovel about it saying things like it's good, cool, super, fantastic etc. On the contrary, I want to say things like it's boring, stupid, a waste of money etc.

Anyway, getting back to the game, I dislike it for a number of reasons and have listed them in points below. 1 People have praised the game for its good descriptions. I think that these descriptions are long, boring, unwitty and generally have nothing to do with the game. For instance, you find your computer telling you that you are in a room which is littered with rusty weapons. Then if you type in GET WEAPONS you get the reply 'I cannot do that'. 2 The game has very little graphics. There are only six or seven pictures in part one and I have completed

two thirds of it. 3 The response is very slow, especially in the caves in part two. On average in the caves, it takes about two minutes (no joke) to get from one location to the next. 4 I feel that the authors got off extremely easy because they did not have to write the story for the game because Tolkien had written it already. All they had to do was convert it to the computer.

I think that this game was not worth the money and people would get more satisfaction out of one of Level 9's games which have an original plot designed by them and all their locations have a picture and they give just enough reading to make the game enjoyable.

Please, please print this letter because I have never got my name in a magazine.

Edmund Prout, Co Waterford, Ireland

I got the impression you didn't like the game.

DB

TALKING TOLKIEN

Dear Derek,
After you printed my letter concerning MELBOURNE HOUSE'S games LORD OF THE RINGS and THE HOBBIT, I expected some criticism, and I was not disappointed (J Baldock's letter, issue 33). I was quite amused by some of the points he raised, no, perhaps amused is not the right word. Anyway, I would like to take this opportunity to answer some of Mr Baldock's points.

He seems to have got the wrong idea, or perhaps I was not very clear in my first letter. I am not saying that LOR is a bad game, in fact I enjoyed playing it immensely, it's just that it doesn't do credit to the book. Both the Tolkien games are good enough to be classed as milestones in adventuring (THE HOBBIT more so as it was an earlier game). Quite how Mr Baldock can say that - 'the descriptions in both games are superb, therefore the atmosphere created is second to none' is beyond me. Here are some location descriptions from THE HOBBIT: 'You are in Rivendell. You can see Elrond. You can go East and West' and 'You are in the Misty Mountains. You can go . . .' etc. Oh yes, very atmospheric, I must say. Let's see, the first example tells us that we are in Rivendell and we can see Elrond. Just what is Rivendell; is it another country, a nightclub or, as the book tells us, the last homely house of Elrond Halfelven in the valley of Rivendell. From the game, we don't know who Elrond is; he could be a Wham! groupie or the Labour party candidate for the Isle of Man!

Past letters in Signpost tell us that most adventure players are in favour of location descriptions of about eight lines. Just how many of these are there in THE HOBBIT? There are some good locations in LOR, but all too often they are replaced by the uninspiring: 'You are in a Leafy Place' etc.

It is true that Philip Mitchell deserved credit for his database after THE HOBBIT, but if he had taken any notice of player's criticisms then surely he would have ironed out the bugs at that stage; instead we all played spot the bug in SHERLOCK and LOR. LEVEL 9'S database (from what I've heard, could be wrong) had a small bug in it which delayed the launch of one of its games. If LEVEL 9 can do it, why can't Philip Mitchell's team?

Of course the player has to 'tread other paths' or the game could be completed simply without any trouble and I appreciate this, but these 'other paths' should keep to the flavour of the rest of the game. The Guardian wrote of Tolkien: 'How, given little over half a century of work, did one man become the creative equivalent of a people'. This man dedicated most of his life to creating Middle Earth and the Undying Lands and it is really annoying to see it ruined by an 'underwater hareem' and a 'heavy metal orc band' (I have nothing against hareems and heavy metal music you understand, they just don't belong in Middle Earth).

As for not reading the instructions, well, I had LOR for Christmas and as usual, I searched the house for my presents and found them a week in advance. I took the instructions out of the box and kept them to read so that I could begin playing as soon as I loaded the game. A pity the instructions forgot to mention the strange loader in the loading instructions - how many people thought their copy was faulty? How can the graphics be some of the best ever used in adventures. THE HOBBIT had some nice graphics and my favourite loading screen of all time, but as for LOR, come on James! Compare these pictures to those in RED MOON, ADVENTURE INTERNATIONAL'S games, ERIC THE VIKING, THE BOGGIT etc.

No, I don't think I could much better myself as I am not a professional programmer, but if Unwin Paperbacks let me, I'll have a damn good try on GAC. I did in fact start to write LOR on the quill but when I found that MELBOURNE HOUSE was bringing it out I had to stop, and character interaction was difficult with verb/noun.

A cheering crowd of Dwarves, Hobbits and Elves appeared, led by Gandalf. They carried you off into the sunset proclaiming you hero of heroes and master adventurer! They all lived happily ever after, James with his game, and David with his book.

David Bovill, Gwynedd

SIGNSTUMPS

Once again THE BOGGIT proves to be the most popular adventure for SIGNSTUMPS. Robert Clay from Stockton-on-Tees writes:

1. How do you kill the three trolls in part 1?
2. How do I get out of the goblin dungeon?
3. In part 3, how do I escape from the room with the trapdoor in it, in the elvenkings dungeon?
4. How can I cross the river in the boat in part 3? I have bought the duty free but still the boat will not move."

To kill the trolls TBZ MYY. To escape from the goblin dungeon, throw the rope until it catches on the window, then pull rope and head southeast. Before you do this you should E JH TBOE, TNBTI USBQEPPS, then get the torch. Escaping from the elvenkings dungeon is very similar to the same problem in The Hobbit. First, wait until someone opens the door and then go south into the cellar, wait for him to open a barrel and then climb inside. Wearing the ring is probably helpful here. To make the boat move UJF CPBU.

On the same game Kez the Sorcerer writes:

"Help! I can anyone tell me how to use the torch? I've tried everything, including USE TORCH, SWITCH ON TORCH, TORCH ON etc."

I'm afraid the torch is a dud! To get light FYBNJOF UPSDI, JOTFSU CBUUFSZ JUP TXPSE.

Duncan Rothwell of Washington writes

"I bought the excellent adventure THE BOGGIT two days ago and I need advice on how to get some food as the sandwich in Beorns house is poisoned and I keep dying from hunger. Also, how can I get into the goblins back gate?"

To get some food, go to Smelrond's house and wait for Gandalf to arrive, Smelrond will then give you some lunch. To enter the goblins back gate TBZ GPPM.

Still on the BOGGIT, M. Nicholson from Wirral asks:

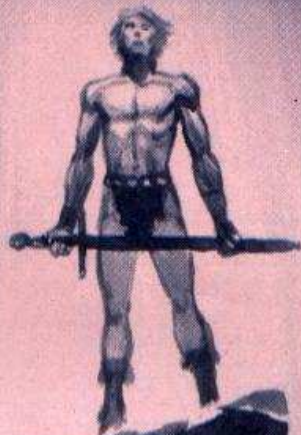

"How do you get off the second screen without being dragged back by a dwarf and how much is a 14th of Thorny's treasure worth?"

To progress you must answer the question you've been asked. The answer 0 (ZERO).

And finally for this month on the BOGGIT William Brown asks how to get inside the cupboard at Beorn's House. Simply use IN to enter and OUT to leave.

S. Kathiravelu of New Malden, Surrey writes:

"I'm stumped on Mastertronic's ZZZZ. Please help me on the following.

1. How do you get the bus?
2. How do you get the bucket unstuck?
3. How do you avoid being arrested for jaywalking?
4. How do you enter the ice palace?"

1. Dunno
2. Get the spade E JH TBOE, MJGU CVDLFU and HFU CVDLFU.
3. Don't jaywalk!
4. Go and get the bike, wheel it to the ice palace and ring the bell.

Gary Gray from Merseyside asks about the golden oldy SMUGGLERS COVE from QUICKSILVA:

"How do I get the key from the lake. How do I get the lifebelt down the pothole and what do you do with the hungry cat?"

If I remember correctly the lifebelt is tied to some munchies. At the stream FLOAT MUNCHIES. These will float down into the lake and make it safe for you to get the key. The cat will follow you while you have some fish and will protect you from the rats.

Stephen Robertson of Gateshead is having a bit of a problem reaching HAMPSTEAD and asks:

1. What is the use of the walkman?
2. What is the lathe bracket for?
3. Is it possible to change into the tweeds without having to go to Waterloo first?
4. Once in the Waterloo area (Piccadilly) how do I get back to the station, then back to N.E. London?
5. What do I do in the Bank?
6. How can I afford the cottage or a suit?
7. Is it possible to visit Richmond or King's Cross without ending the game?
8. Where is the cabinet that needs to be forced?
9. How do I get a job?"

- 1 Don't think it's of any use.
- 2 Give it to Justin on the train.
- 3 You can drop the tracksuit and wear the tweed in the Oxfam shop.
- 4 You don't need to!
- 5 Get a Job?
- 6 I think you need the credit card that's under the bench on Hampstead Heath to buy the suit.
- 7 Don't think so.
- 8 You need to get a job first.
- 9 Go to the club wearing a tie and suit. When asked your name offer card and accept offer.

Finally for this month David Sykes of Halifax writes:

"Please could you help me on SEABASE DELTA? How do you get the loose magnet out of the loudspeaker? How do you get the plank from the deck?"

To get the magnet VOTDSFX NBHOFT (you need the screwdriver), HFU NBHOFT. To get the plank you need the pincers, GVMM OBJMT.

That's all there is time for this month - pub closes in 31 mins and 5 seconds (captain) - must dash.

Find out how to keep goal like Peter Shilton

NET A FOOTBALL SIGNED BY THE WHOLE ENGLAND SQUAD

**Crash
Competition**

ARGUS PRESS have graced the software shelves with many a computer game *Glider Rider*, *Miami Dice*, etc . . . etc to name but a few and flushed with their success, the very modest (but highly imaginative and creative) Peter Holme has now kicked off a new label devoted to sporting simulations called *Grand Slam*. Pulling out all the stops he's got Peter Shilton to add his name to the label's first release *Hand Ball Maradona*. The man's brilliance does not end here. He even managed to get Peter Shilton's son Micheal to play test the game at no extra expense. Yes here is a man who is not afraid of a little running around in the name of sport. Unfortunately Argus's love of physical punishment is not shared by all. There is nothing else that will send the CRASH minions running for cover better than the mention of the word ce-pe-oh-re-te (SPORT). Yes, their aversion to the odd bouts of journalistic activity is second only to the threat of any heavily physical pastime. The threat is such that Captain Kidd, he of the Doc Martins, moved upward to his higher post that offered the deep comfort of executive padded chair, salubrious office with connecting trainee tea

person. Hannah Smiff, she of handbag and girlie wiffs fame, finds her favourite sport to be a little early morning Lee baiting which although is not overly athletic does have the poor chappie wheezing and panting with purple face and protruding veins before lunchtime. Perhaps he would fare better if his favourite sport wasn't playing statues and using so much of energies in finding out who's turn it is to make the tea (usually mine).

Yes, what they need is a little exercise, but as they would all bemoan they haven't developed the correct muscles for running around. The only muscular parts on any of them is around the base of the thumb which is constantly exercised by the fervoured use of fire buttons and the flicking of the deadly elastic bands indicative of the current sport of alien (and Minion) bashing.

If you find yourself in a similar position then why not get yourself a copy of *Hand Ball Maradona* to play an exhilarating game of football without having to don boots, shorts and shin pads or plunge into the obligatory bath with all those other muddy bodies. If you're the lucky winner there is a **FIRST PRIZE** of a top quality foot-

ball signed by all the members of the England World Cup Squad. Of course, you wouldn't want to get it all muddy or anything, just pose around the sportsfield with it. For the lucky fifty **RUNNERS UP** there's a copy of the game.

All you have to do is to answer the following questions about Peter Shilton and the game of football

1. How old was Peter when he made his league debut?
2. Which clubs has he played for?
3. Who were the other goalkeepers in the World Cup party this year in Mexico?
4. What do you think Mr. Shilton said to Mr. Maradona after the infamous incident? Don't forget, the comps minion leads a sheltered life in his executive broom cupboard, so no nasty rude words please!

Send the answers to us on a postcard to arrive here by 30th of December, but don't get caught out in the Xmas postal log jam. Address them to **HERE WE GO, HERE WE GO, HERE WE GO, CRASH, PO Box 10, Ludlow, Shropshire, SY8 1DB.**





SPECTRUM Hospital & Services - DIRECTORY -

EAST ANGLIA	EAST MIDLANDS	SOUTH WEST/WALES	LONDON/SOUTH EAST
<p>R. A. ELECTRONICS 133 London Road South, Lowestoft, Suffolk ☎ 0502 66289</p> <p>Spectrum repairs £17 fully inclusive Keyboard £12</p>	<p>MICRO-MEND Main Street, Farcet, Peterborough PE7 3DB ☎ (0733) 241718</p> <p>New, low fixed prices: Spectrum £17, M/drive £18, I/face1 £18, ZX Printer £18. All inc + PP. £1.80</p>	<p>£180 for 6 months! Get read by 000's of Spectrum owners! Advertise your services here!</p>	<p>CHILTERN COMPUTER CENTRE 98/100 High Town Road Luton, Bedfordshire ☎ (0562) 455684</p> <p>Spectrum repairs £16.00. 3 month warranty. Full range of computer repairs, inc peripherals. Fast, reliable service.</p>
<p>£180 for 6 months! Get read by 000's of Spectrum owners! Advertise your services here!</p>	<p>£180 for 6 months! Get read by 000's of Spectrum owners! Advertise your services here!</p>	<p>CAPITAL COMPUTER SERVICES Unit K2, Cardiff Workshops, Lewis Rd, East Moors, Cardiff CF1 5EG ☎ Cardiff (0222) 461801</p> <p>Spectrum repairs £17 fully inc. 3 month warranty, fast and reliable service</p>	<p>£180 for 6 months! Get read by 000's of Spectrum owners! Advertise your services here!</p>
<p>£180 for 6 months! Get read by 000's of Spectrum owners! Advertise your services here!</p>	<p>SPECTRUM HOSPITAL CENTRALISED SERVICES LTD Piccadilly, Bulwell, Nottingham NG6 9FN. ☎ 0602 751153</p> <p>Spectrum repairs £17.00, microdrive/Interface £17.00, also keyboard repairs. All prices include insured return delivery. 24 hour service.</p>	<p>£180 for 6 months! Get read by 000's of Spectrum owners! Advertise your services here!</p>	<p>£180 for 6 months! Get read by 000's of Spectrum owners! Advertise your services here!</p>
<p>£180 for 6 months! Get read by 000's of Spectrum owners! Advertise your services here!</p>	<p>£180 for 6 months! Get read by 000's of Spectrum owners! Advertise your services here!</p>	<p>I. T. WESTERN ELECTRONICS Unit S2A & S3, Avonside Enter- prise Park, Newbroughton Rd, Melksham, Wilts. ☎ 0225 705017</p> <p>Repairs: Spectrum/Plus £12.00, keyboard £8.30, Interface & Microdrive £17.00 each. All fully inclusive. Callers welcome.</p>	<p>£180 for 6 months! Get read by 000's of Spectrum owners! Advertise your services here!</p>
<p>£180 for 6 months! Get read by 000's of Spectrum owners! Advertise your services here!</p>	<p>WEST MIDLANDS</p> <p>£180 for 6 months! Get read by 000's of Spectrum owners! Advertise your services here!</p>	<p>£180 for 6 months! Get read by 000's of Spectrum owners! Advertise your services here!</p>	<p>NORTH WEST</p> <p>£180 for 6 months! Get read by 000's of Spectrum owners! Advertise your services here!</p>
<p>NORTH EAST</p> <p>£180 for 6 months! Get read by 000's of Spectrum owners! Advertise your services here!</p>	<p>£180 for 6 months! Get read by 000's of Spectrum owners! Advertise your services here!</p>	<p>£180 for 6 months! Get read by 000's of Spectrum owners! Advertise your services here!</p>	<p>H. S. COMPUTER SERVICES Unit 2, The Orchard, Warton, Preston, Lancashire PR4 1BE ☎ (0772) 632686</p> <p>Repairs £14.95 fully inc; 24 hrs turn-round. 3 month guarantee. Why pay more?</p>
<p>SCOTLAND</p> <p>MICRO SERV 95 Doerdykes View, Westfield Ind. Area, Cumbernauld G68 9HN ☎ 02367 37110</p> <p>Repairs to all Sinclair range, inc. interface, Microdrive, monitors. 3 month warranty. Free estimates.</p>	<p>£180 for 6 months! Get read by 000's of Spectrum owners! Advertise your services here!</p>	<p>SYNTAX COMPUTERS LTD 76 Cornwall Street Plymouth, Devon PL1 1NS ☎ (0752) 228705</p> <p>Sinclair, Commodore, Amstrad and BBC Repair Specialists 3 month warranty</p>	<p>£180 for 6 months! Get read by 000's of Spectrum owners! Advertise your services here!</p>
<p>£180 for 6 months! Get read by 000's of Spectrum owners! Advertise your services here!</p>	<p>THOMAS WALKER & SON 37/41 Bisset Street Birmingham B5 7HR ☎ 021-622 4475</p> <p>Repairs to Sinclair, Commodore, BBC and and other make on request. Free quote facility.</p>	<p>For details of advertising in this section, contact Nick Wild on (0584) 4603 or write to him at Newsfield Publications, 1/2 King Street, Ludlow, Shropshire, SY8 1DB</p>	<p>£180 for 6 months! Get read by 000's of Spectrum owners! Advertise your services here!</p>

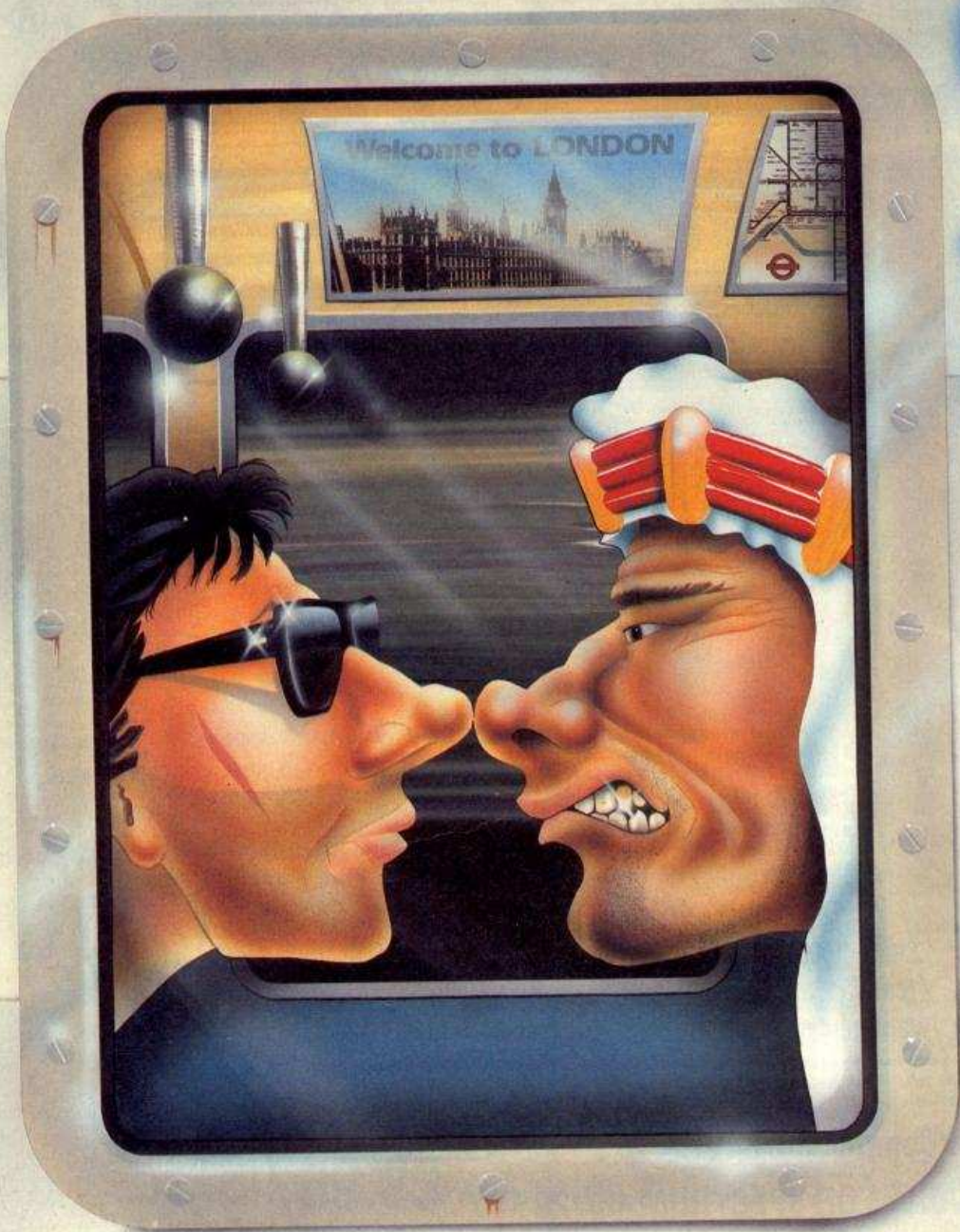

City Slicker

**GIVE IT SOME STICK
WITH THE SLICKER**

Get on the move with Slick, our offbeat tec defuse the demonic plot of sadistic Abru Cadabra in his manic attempt to obliterate the Houses of Parliament. Ride the rails through the cut-throat perils of the Underground expose yourself to the harsh humour of low-life London but keep your street credibility at all times. Against the odds, it is vital you save the nation's prestigious seat of power. The survival of Law, Order and Society as we know it, depends on YOU.



Spectrum Cassette £8.95
Amstrad Cassette £8.95
Amstrad Disk £14.95

For Mail Order send a cheque/P.O to Hewson Consultants Ltd. Order by Credit Card sending your Access/Barclaycard number, and a specimen signature. Don't forget to enclose your name and address.

HEWSON

56b Milton Trading Estate, Milton, Abingdon, Oxon. OX14 4RX

As part of our continuing development of innovative software we are always happy to evaluate software sent to us with a view to publication.

SCALEXTRIC®

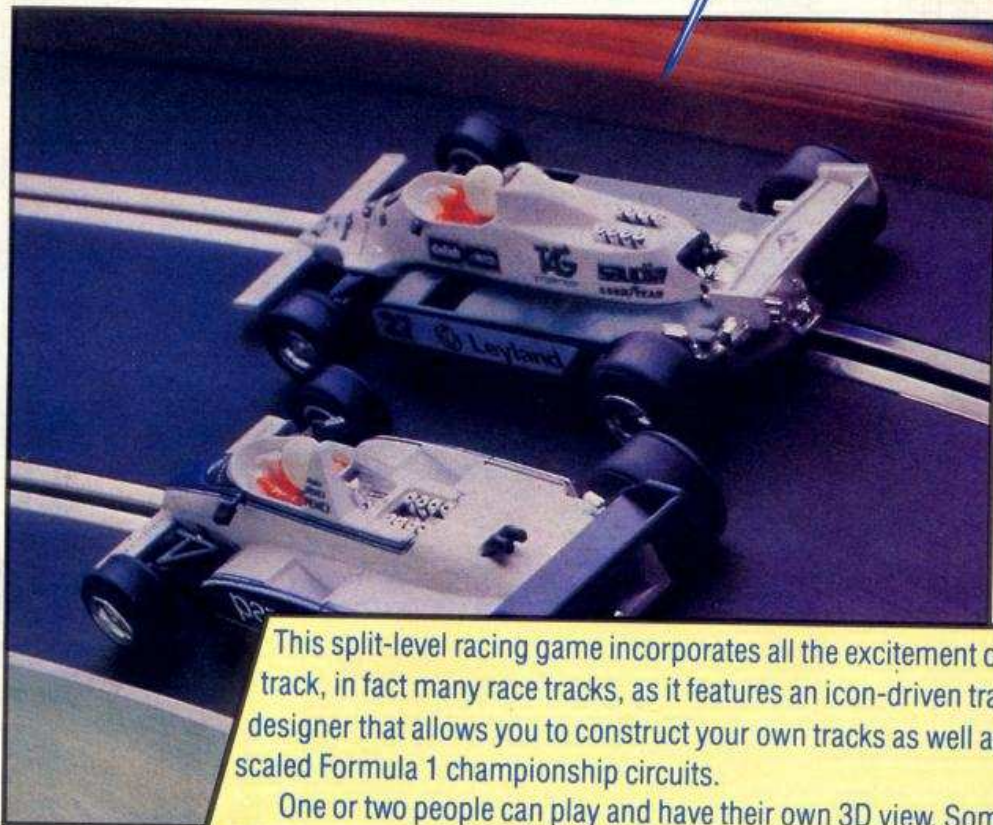

This split-level racing game incorporates all the excitement of the race track, in fact many race tracks, as it features an icon-driven track designer that allows you to construct your own tracks as well as select scaled Formula 1 championship circuits.

One or two people can play and have their own 3D view. Some ingenious programming has made the feel of controlling the cars very realistic, and you can even bump and push your opponent's car if you want to play dirty!

Available for Commodore 64 at **£9.95**
NOW AVAILABLE FOR SPECTRUM 48/128 AT £9.95
and coming soon for AMSTRAD CPC computers!

SCALEXTRIC® IS A REGISTERED TRADE-MARK OF HORNBY HOBBIES LTD. © ALL COPYRIGHTS RESERVED. Leisure Genius® is a wholly owned subsidiary of Virgin Games Ltd.

Please send me a copy of **SCALEXTRIC** at **£9.95**
COMMODORE 64/128 SPECTRUM 48/128

Name _____

Address _____

Please make cheques and postal order payable to **Virgin Games Ltd.**, and post to **Virgin Games, 2/4 Vernon Yard, Portobello Road, London W11 2DX.** Please do not post cash.

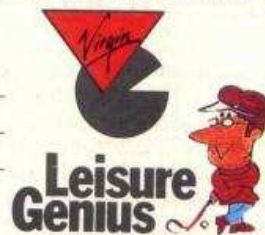

Heannah Smith

PLAYING TIPS



It's a slightly smaller Playing Tips this month I'm afraid, but I'm saving myself for the epic Christmas Special. Before I go any further I must apologise to David Thompson who wrote to Lloyd last month requesting the rest of the Incredible *Shrinking Fireman* Tips. Well, David, it's like this...ahem...the solution to this game seems to have sort of gawn missing from my Tips Library. However, rest assured that as soon as some nice person sends this solution in to me I'll stick it straight in Playing Tips, hokay?

This month there's a *Glider Rider* map from Peter Roe and Jamie Huggart, the *Map Lads* from Macclesfield. Adrian Thomas sent in a map for the first four planets of *Thrust Lightforce*, that devilish game from FTL has been almost cracked by Paul Turland who's sent in maps for the Asteroid Belt and The Jungle Planet. This clever bit of mapping earns Paul Cartographer of the Month award. And for desertipooos, ma leetle Frenchipoo Tips Reading Persons, another section of the *Equinox* map for you.

On the tips front, Chris Jetman Turner wins Top Tipster Award for his excellent *Glider Rider* POKEs. There are some *Trapdoor* tips as well as help on *Lightforce*.

I'm just off to Ludlow's Shapla Tandoori Restaurant for a quick *Korai Special* after work. It's drizzling here in the sticks and there's not the slightest hint of snow, although according to the long range weather forecast, Graeme will soon have to break out his special Snow Plough Doc Martens!

Mini Tips.

Last month those Industrious Hackers From Haxby and Pocklington sent in some mammoth POKEs for V. This month those clever and hard working lads have sent in some tips to help you complete the rest of the game (assuming that you've already got quite a long way using the POKEs).

Once you have deposited all your bombs in the correct places (CLUE: One on each level and not in the laboratories) and deposited your red dust, all you have to do is go to the docking bay and press up. You should then see a Hamburger-shaped ship flying away from the mother ship with a message *Farewell Donavon, until we meet again - Diana* and then there's a big explosion and that's it. Let's hope that these tips, along with the POKEs will enable more people to finish V. I have it on good authority that the ending is quite interesting.

TRAP DOOR TIPS.

Trapdoor narrowly missed being a CRASH SMASH a few months back. In the game you control Berk, a poor put upon character who has to pander to his master's whims (rather like our beloved Comps Minion really!). Berk has to prepare all sorts of sumptuous meals for 'im upstairs and each one has a rather unusual recipe. Poor old Berk has to troll around the large castle collecting all manner of strange creatures to make into his master's supper. So far only a few solutions have come in for *Trapdoor*, but seeing as how the game has been out for some time now, here's the way to prepare a Can Of Worms and some Crushed Eyeballs. Richard Langford from Middlesex is to thank for this little culinary delicacy.

Collect the can from the kitchen and take it to the room with the trapdoor. Open the trapdoor to release the worms. Try to collect them before Drutt eats them! Drop the worms into the can - at least two are

needed. If you don't have quite enough, just get Berk to open the trapdoor again to release some more. Before you put the can in the dumb-waiter try to prepare the Boiled Slimies and Crushed Eyeballs if you have enough time, as this will aid you later in the game.

To make the Crushed Eyeballs, take the yellow pot from the kitchen and empty it. There should be a box of seeds inside. Take the box to the room left of the kitchen and empty it. This will give you three small eyeballs. Put one small eyeball into each pot and a plant will start to grow. While these strange plants grow, push the vat in the kitchen to the farthest wall. By this time the plants should have grown to give you three large eyeballs. Carry each one back to the kitchen and drop them in the vat. Release the tall jumping monster with the stripey tights from the trapdoor and position the vat so that the monster will jump into it and crush the eyes (eugh). Make sure the bottle is still under the tap! Take the bottle and its contents of crushed eyeballs and send it up in the dumb-waiter. Open the trapdoor and the jumping monster will eventually jump back in. Eventually...?

In the Christmas Special I'll give you the solution to make Boiled Slimies and Fried Eggs and how to finish the game in Trainee Berk mode and as a Super Berk.

HIJACK TIPS

I received a mysterious letter from The Mega Team a few weeks ago. There was no address enclosed and no names. Very strange. All they were prepared to tell me was that they are the BEST when it comes to mapping and giving tips to games. Maybe they're following in the footsteps of the Industrious Hackers from Haxby (and pocklington). Anyway, The Mega Team have provided me with these tips for *Hijack* to go with the map printed last month. Take it away whoever you are!

1. Find the Financial Officer as soon as possible and tell him to

raise some cash. You will need to keep on reminding him every few minutes (terribly short attention span, these Civil Servants).

2. When you find the CIA agent, order him to make the longest report possible, but still leave about 3 mins in which to find the file which will be hidden in a certain filing cabinet.

3. You are given two codes in the game. When entered into the correct computers, these will present you with the status report of the Department. The second code gives you information about known terrorist movement.

4. At the start the President is willing to negotiate for a deadline extension, but won't help with anything else. Keep issuing press statements to aid publicity as this will put Mr. President in an amicable mood.

5. Send out all the Diplomats available and about half the military.

6. The experience and loyalty of your staff can be discovered from the files in the records office.

There, that should be enough to get you started on this ingenious game. Perhaps by next month someone will have been kind enough to send in the complete solution.

LIGHTFORCE TIPS

The anonymous Mega Team have sent in some tips on *Lightforce*, for those of you who don't like using POKEs in order to complete games. This issue there are solutions to the Asteroid Belt and the Jungle planet. Next issue there'll be the solution to help you through the Orbital Platforms and the Ice Planet. Anyway here goes, (Oh, by the way Mega Team you're never going to win the Top Tipsters award if you don't include your names and addresses you know!) the numbers represent the attack waves in the order which they appear.

ASTEROID BELT

The most important thing to remember is to stay at the bottom of the screen on this level.

1. Shootable Aliens - This bit's very easy. Just take them out as they descend but watch out for the fast ones

2. Unshootable aliens - Just be very wary and dodge. You can lure them away from the ground bases so that the ground bases can be shot without any hassle from the aliens.

3. Alien Formation (a)

i) Easy: just dodge bullets as they fly away

ii) Get to just right of the centre of the screen. Shoot the three aliens on the right as they come up to meet you, then quickly move to just left of centre and take out the other three as they descend

iii) Get to almost the extreme right of the screen and shoot the

three aliens. Move under the large planet and shoot the others as they come in.

4. Unshootable asteroids - avoid like the plague

5. Homing aliens - Move to the middle and weave left and right, shooting all the time

6. Alien Formation (b)

i) Move to the middle of the screen. Follow bottom aliens left to right, shooting continuously. Stop when all have been destroyed but continue shooting to take out the others as they swirl off the edge of the screen.

ii) Same as figure i) only shoot right to left

7. Unshootables

8. Homers again (Eeek)

JUNGLE PLANET

1. Some spherical aliens will attack you from behind. But because you are at the bottom of the screen they can't destroy you (ha!). Treat them like homers as they descend.

2. Zig-zag aliens attack - they are indestructible and very, very fast.

3. Alien Formation (c)

i) Move to the extreme right of the screen shooting continuously. When the three aliens on the right are eliminated go to the extreme left, quickly.

ii) Shoot behind you attacking the aliens as they come out and go right after each attack. Stay almost to the extreme right at all times during this part.

iii) Shoot the aliens to the right. Stay to the right, shooting

continuously. When all aliens have been eliminated, go to the extreme right and squeeze past any spare missiles.

4. Cross shapes aliens attack. They behave exactly like the shootable asteroids.

5. Alien formation (a) These home in at the end. Just attack them. The first attack wave is more difficult really. Simply shoot the three to the right, move into the middle and take out the rest as they drop on you.

6. Life Locator - You must blast away at the ground installations. Behind you appears a smiling face which represents an extra bonus life.

7. Move to the right of the screen so that the right of the

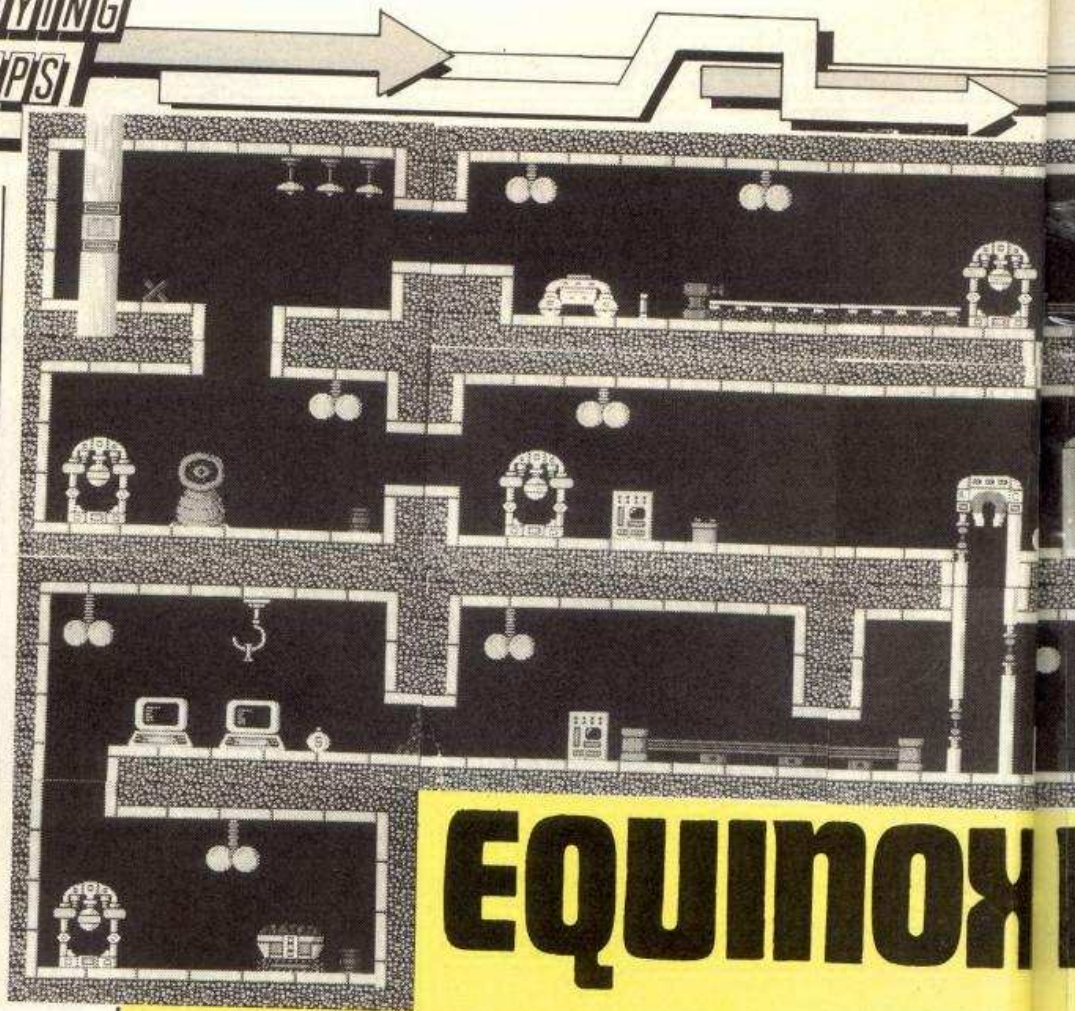

EQUINOX

KEY-

↔ PASSAGE

X → ONE WAY

□ TELEPORT

TELEPORT KEY:-

1 - ZEPHA

2 - XYLEM

3 - NITRO

4 - CRYPT

5 - DELTA

6 - QUART

7 - ASTRA

8 - YRT ON

MAPPED BY THE MEGA-TEAM

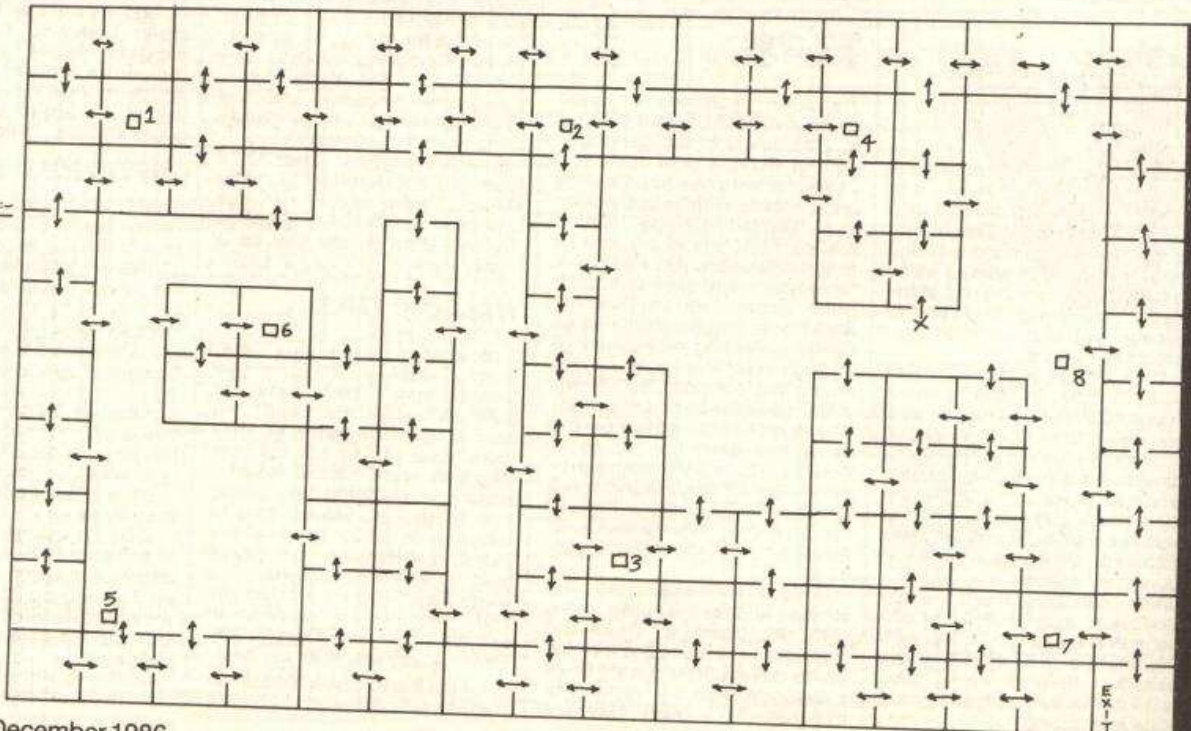

BOMBSCARE MAP

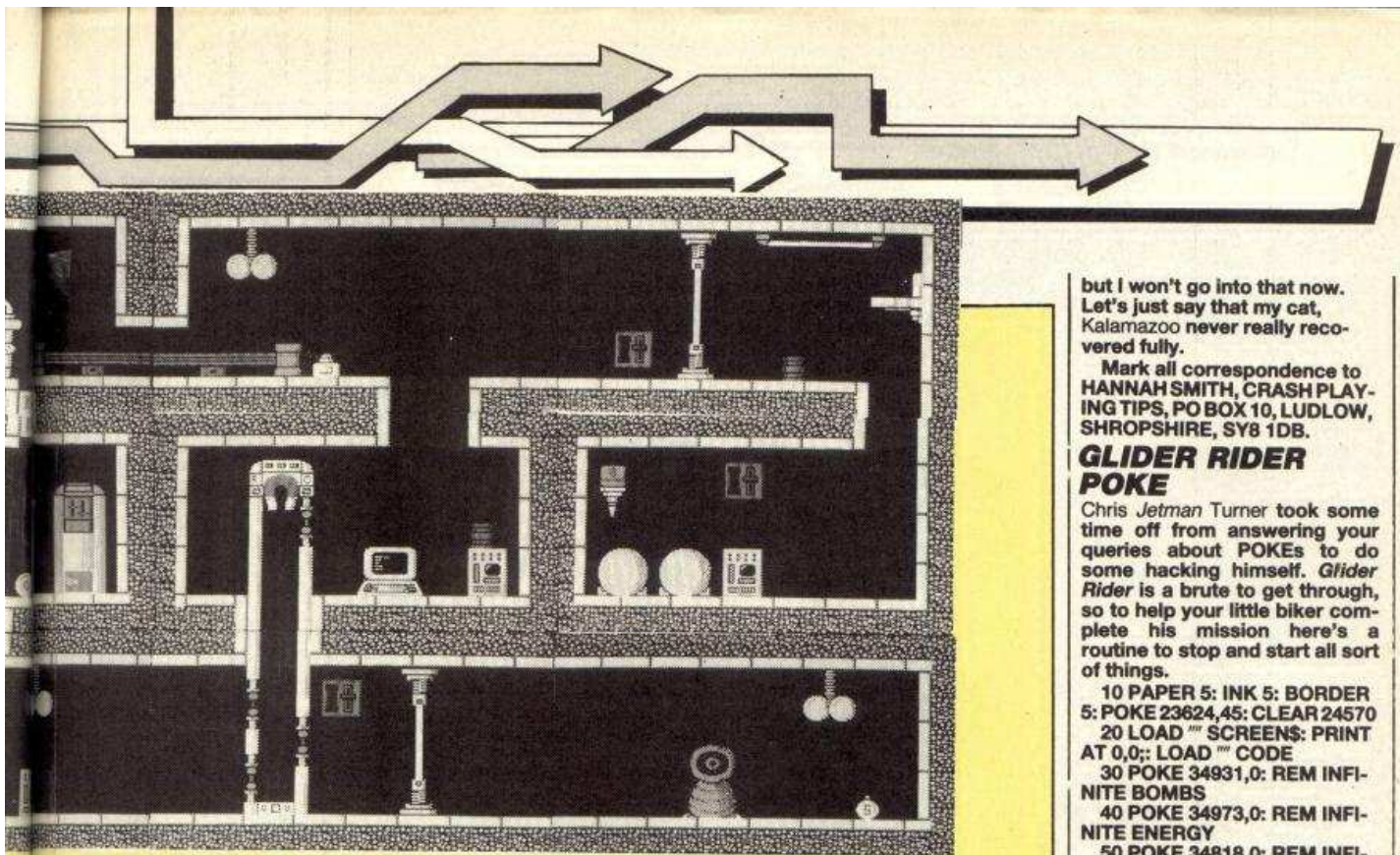

MAP LEVEL 7

but I won't go into that now. Let's just say that my cat, Kalamazoo never really recovered fully.

Mark all correspondence to HANNAH SMITH, CRASH PLAYING TIPS, PO BOX 10, LUDLOW, SHROPSHIRE, SY8 1DB.

GLIDER RIDER POKE

Chris Jetman Turner took some time off from answering your queries about POKES to do some hacking himself. *Glider Rider* is a brute to get through, so to help your little biker complete his mission here's a routine to stop and start all sort of things.

10 PAPER 5; INK 5; BORDER 5; POKE 23624,45; CLEAR 24570
20 LOAD "" SCREENS: PRINT AT 0,0; LOAD "" CODE

30 POKE 34931,0; REM INFINITE BOMBS

40 POKE 34973,0; REM INFINITE ENERGY

50 POKE 34818,0; REM INFINITE TIME

60 POKE 34829,0; REM SLOWER TIME COUNT

70 POKE 37439,0; POKE 37440,0; REM DISABLES LASERS

80 POKE 37461,0; POKE 37462,0; POKE 37463,0; REM NO DIRECTION CHANGE WHEN LASERS HIT

90 RANDOMIZE USR 30720

ship is just touching the black, inset border. Shoot continuously and you shouldn't need to move. If an alien does get through, then hop upwards in order to avoid it. There are two of these attacks.

8. More shootable cross aliens.

9. Alien formation (d)
i) Same as in C (i)
ii) move right, shooting rapidly
iii) Move to the extreme left shooting quickly. Hop upwards to avoid top alien as it nears the bottom of the screen

iv) A short relatively easy individual diagonal attack.

10. Life Locate.

11. Spherical homers attack from behind. They eventually merge into ordinary Homing asteroids.

BOMBS CARE TIPS

To go with the *Bombscare* map this issue here are some tips for the game as sent in by David Taylor from Edinburgh.

The teleport codes in the game which you will need to know before you can travel about freely are:

ZEPHA
QUART
XYLEM
CRYPT
YTON
DELTA
ASTRA
NITRO

These are the useful objects in the game and which useful function they perform:
The Stick of Dynamite will destroy all creatures in a room
The Bomb and the Star do the same

The Half Prism will teleport you back to the start of the game and the Full Prism will teleport you to the exit

The Bottle restores your energy
The Shield does the same

The Clock will pause the timer
A Miniature figure gives you an extra man

The Gun restores your fire power

To complete the game, these objects must be found: Screwdriver, Pliers, Mallet, Monkey Wrench. When you have found these objects, go back to the start.

And once again that's it for another month. Next issue will contain the Bumper Christmas Special Edition of Playing Tips for you to read while your Christmas dinner is going down. Lets hope that with the new year I shall receive even more tips and have an even better Playing Tips section. How about something on *Deactivators*, Durrell's *Fat Worm Blows a Sparky*, and *Scooby Doo* (that is if it's out by then!). Anyway, until next month have fun preparing for Christmas and make sure you test those Christmas tree lights before you put them up. I had a horrible experience last year,



FOOTBALL DIRECTOR



ONLY AVAILABLE ON CDR OR /SPECTRUM

FIXTURE LIST • FOUR LEAGUES • P.W.D.I.F.A.PTS • 20 TEAMS EACH • 38 GAME SEASON • HOME & AWAY
SCOUTS • PHYSIO • FA & LEAGUE CUPS • REPLAYS • INJURIES • BANGLE • FREE TRANSFERS • RETIREMENTS
COACH • YOUTH TEAM • CUP WINNERS CUP • EUROPEAN CUP • U.E.F.A. CUP • 2 LEGS • AGGREGATE • PENALTIES
SUBSTITUTION • BUY / SELL SHARES • TRANSFER MARKET • INTERNATIONALS • EUROPEAN TOURS • 3 LEVELS
POSTPONEMENTS • MIDWEEK GAMES • MANAGER RATING • WEEKLY NEWS • SEASON TICKETS • MUCH MORE

2 PLAYER SUPER LEAGUE

— MANY OF THE ABOVE FEATURES, BUT YOU CAN PLAY AGAINST A FRIEND —
— EACH GAME £4.99 (BOTH GAMES £9.50) —

D&H GAMES ENCLOSE CHQ/P.O. + LARGE S.A.E
WITH 20P STAMP ATTACHED PER CASSETTE

19 MELNE RD, STEVENAGE, HERTS, SG2 8LL

• MAKES THE OTHERS LOOK LIKE THE SUNDAY LEAGUE •

AT LAST!

COMMODORE SPARES

AT REALISTIC PRICES WITH FREE SOCKET

CIA	6526	£17.99	ROM	901227-03	£15.99
MPU	6510	£17.99	ROM	901225-01	£15.99
PLA	906114-01	£18.99	SOUND	6581	£17.99
ROM	901226-01	£15.99	RAM	4164	£2.49

C64 POWER SUPPLY UNITS £24.99

All prices include post & packing, handling and VAT - or send your faulty computer and P.S.U. for free estimate and repair from £9.99 + parts

Spectrum low-priced spares and repairs

SEND CHEQUE/P.O. TO

ELECTRONIC SERVICES

176 VICTORIA ROAD WEST, CLEVELEYS, BLACKPOOL FY5 3NE
Tel. (0253) 822708

TRADE ENQUIRIES WELCOME

Send large S.A.E. for full list

GLIDER RIDER

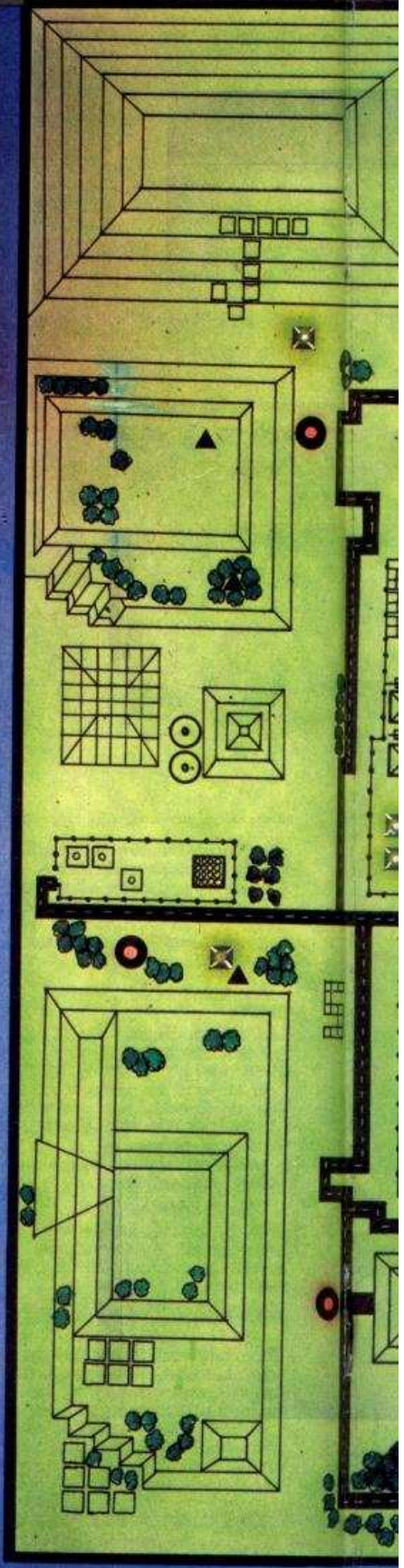
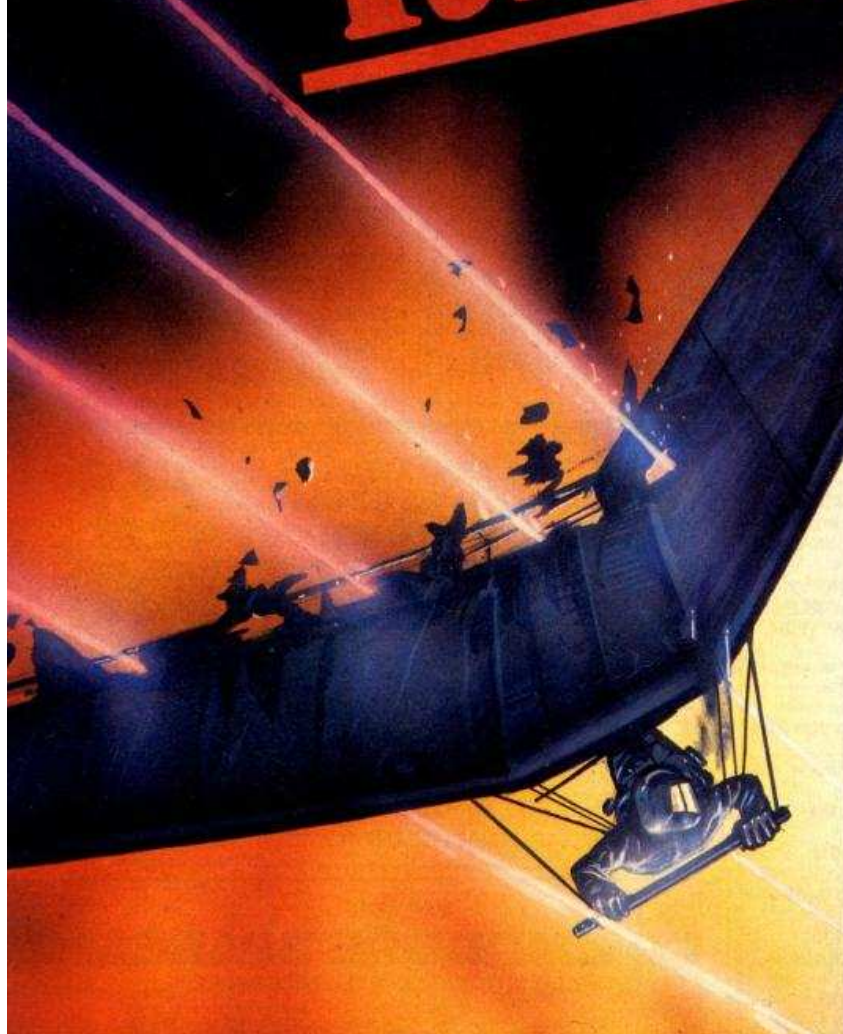

KEY: MAP COMPILED BY JAMIE HUGGET/PETE ROR.

	- HILL		- WINDOWS + CONCRETE SHELTERS		- AMMO DUMP
	- ROAD		- FENCE		- SHELTERS
	- TREES		- TANKS		- GATE
	- REACTOR		- BLOCKADES		- BOMB PROOF CONCRETE
	- LASERS		- MISSILES		- CONCRETE BLOCK
	- LASER CONTROL PYLON				

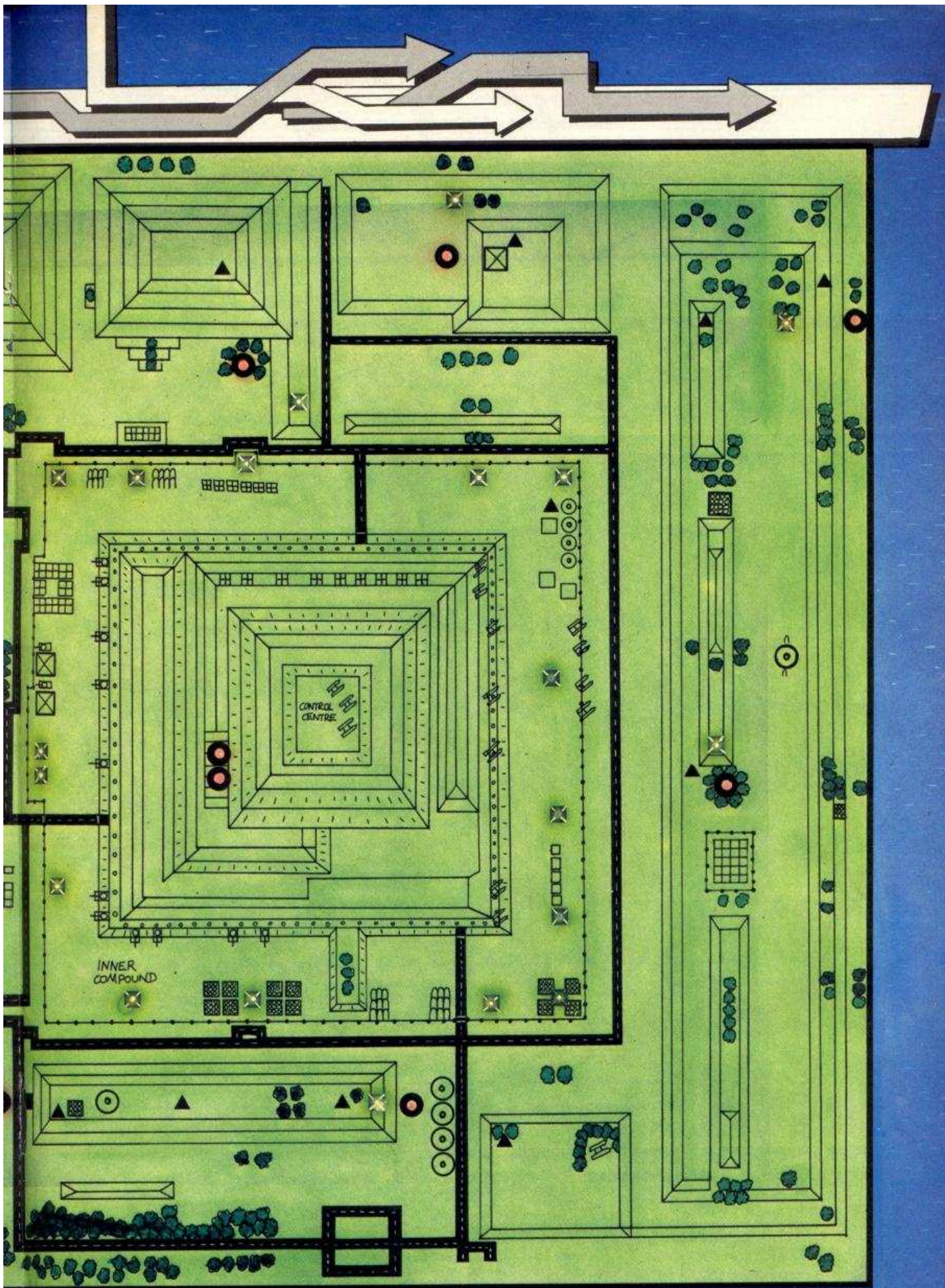

SUPER SOCCER

THE GAME OF THE SEASON

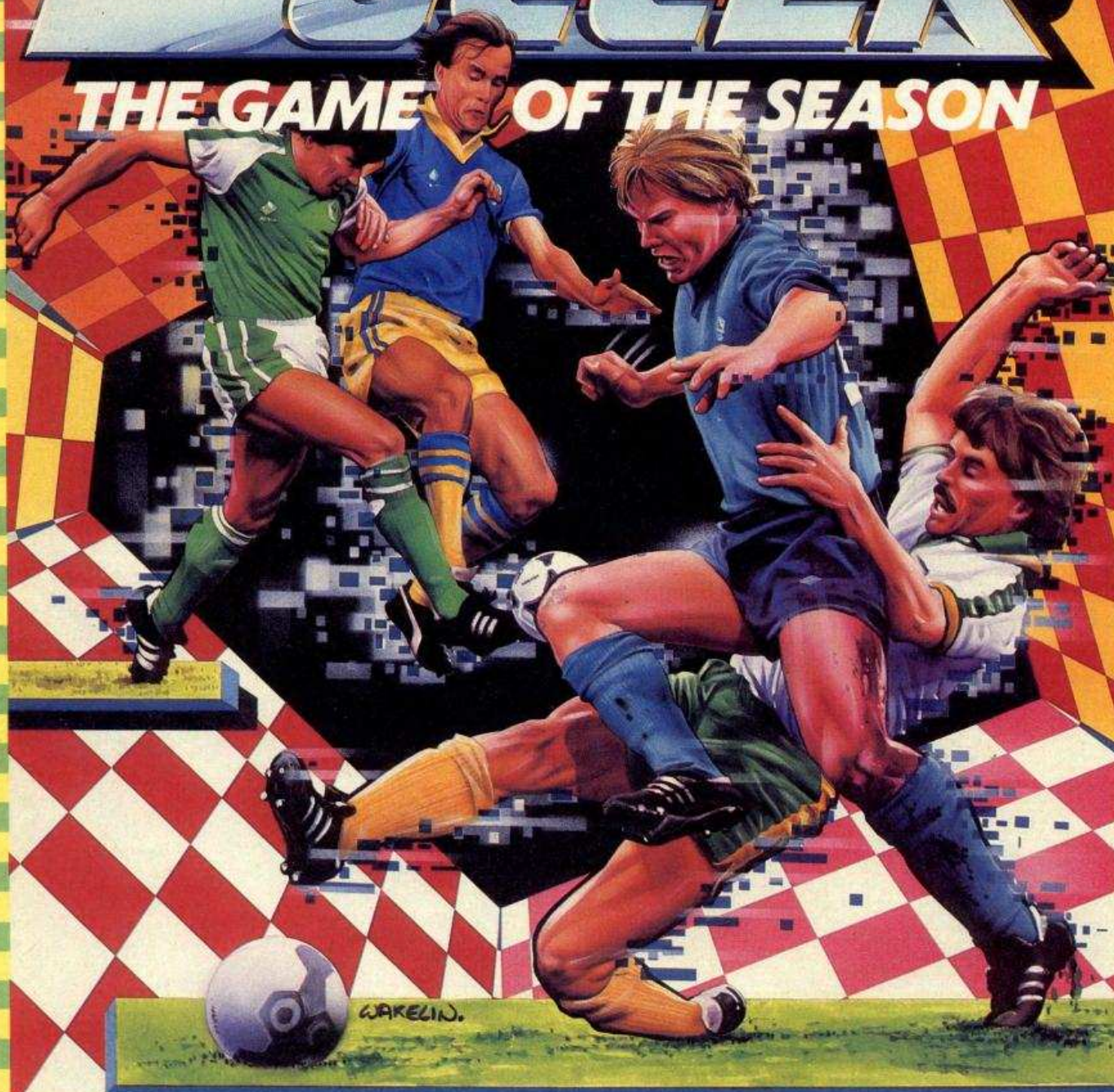

We think Super Soccer is the best computer soccer simulator yet. Be Maradona on screen.

You can dribble past opponents, slide tackle, make crosses, even attempt diving headers. But what makes this game outstanding in its own field is the control you can exercise over the ball. No other game allows you to control the strength of your sharp shooting and ball passing like Super Soccer does.

What's more, when taking free kicks you can organise the whole team with the "full team positional play" feature.

This is a 1 or 2 player game and there's an optional

extra which allows up to 8 separate players to participate in a tournament competition.

So get on the ball in the game of the season.

£7.95 SPECTRUM ONLY.

ocean

Ocean Software Ltd., 6 Central Street, Manchester M2 5NS.
Telephone: 061-832 6633. Telex: 669977 OCEAN G.

Ocean Software; Distributed in France by Ocean France, Telephone: 93-42-7144. Distributed in Germany by Rushware, Telephone: 2101-70040.

Thrust Map

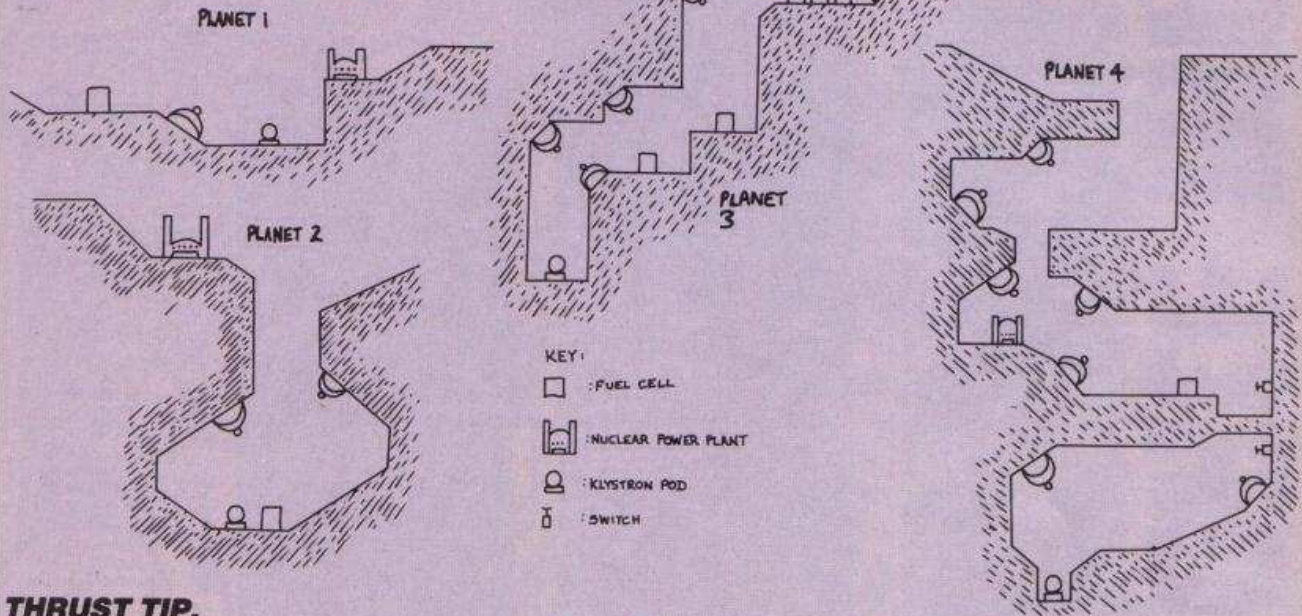

THRUST TIP.

To go with his *Thrust* map, Adrian Thomas has also sent in some tips to get you on your way with the mission. By the way, I hope that none of you have used those POKES yet for the game which I printed last month..!!

1. Do not use the shields unless it's really necessary, because using them drains your

fuel quite quickly

2. You can destroy a planet before you even have a pod. When this happens you will automatically go on to the next one.

3. Only blow up planets one, two and three because you will not have enough time for any others.

4. You can blow the pod up yourself when you're carrying it, so beware.

5. Always blow up guns and fuel cells on the way in towards the planet, because they will only get in the way when you're carrying the pod back out again.

6. On planet four you will encounter a dead end. To get

past this, shoot the switch and the wall opens for a short while.

These tips are very simple but should help you to get started. Adrian has only managed to get to planet four, as his map shows, so maps of the remaining planets and tips on the rest of the game would be greatly appreciated.

OLLI AND LISSA TIPS

This cutie game from Firebird got quite a respectable rating in CRASH last month. Despite the simple idea of the game it's quite tricky to solve some of the later screens. Robin Ibbeson from Rotherham in South Yorkshire obviously had no problems with it however, because he's sent in some Playing Tips. Here's the way to get through the first four stages in the game.

STAGE ONE

This stage is pretty straightforward so I'll skip through it quite quickly. Take Olli to the left of the screen and jump over the Octopus. Get the lamp and run to the stairs. Jump up the stairs and if you have to, jump over the gnome. Then jump up the second set of stairs. Give the lamp to Lissa and you've finished stage one.

STAGE TWO

Sir Humphry will tell you to get

the Diamond. Do not rush into the second screen or you'll run straight into the arms of a waiting frog (eugh). When the frog starts to go to the right, follow it and stop at about the second window. The frog will start to go back to the left when it reaches the gap between the two portcullis'. Now walk down the steps, and wait at the bottom next to the suit of armour. When the small ghost has reached the suit of armour it will start to go to the left. Follow it and start to go down the steps. When you get to the second step from the bottom, stop. Wait there until the second small ghost has gone past the stairs and then go down the rest of the stairs. As soon as Olli reaches the floor, jump over the second small ghost and run to the diamond. Then wait next to the suit of armour's spear until the second ghost has started to move towards the stairs. Run after it and jump up the stairs to the 4th one from the bottom. Wait until the first ghost has passed Olli and jump up the rest of the

steps. Run and jump up the next lot of stairs, jump over the frog and run through to the first stage. Give the diamond to Lissa.

STAGE THREE

Sir Humphry will now command you to find a scroll. Follow the directions given in stage two, but at the bottom of the screen go through the door at the right hand corner. Olli is now outside the castle. You will notice that the bats aren't in line with the battlements. Keep on the side which is least in line with the bat. Get to the part just before the battlements hole and jump, making sure first that the bat is out of the way. Now move a little and then jump onto the second part of the battlement. Now you can move further on and jump onto the third bit of the battlement. After you have done this, jump onto the grass verge on the right hand side and collect the scroll. Jump back to the third bit of battlement if there's not a bat in the way and then jump onto

the second bit. Finally jump across to the first bit of battlement (minding the bat), and race back to the castle following the instructions for the previous screens.

STAGE FOUR

Sir Humphry now tells you to get a mushroom. Follow the directions to get through screens 1, 2 and 3. When the worm has gone, jump onto the bump in the grass and wait until the worm comes back and then jump over it and grab the mushroom at the other end of the screen. When the worm has reached the bump at the right hand side it will turn around. Follow the worm and when Olli gets to a little bump in the grass, jump onto the big bump and then over the worm. Follow the instruction to get you back to the cauldron.

Hopefully next issue there'll be the solution to the rest of the game so send in your tips NOW.

LIGHTFORCE MAP

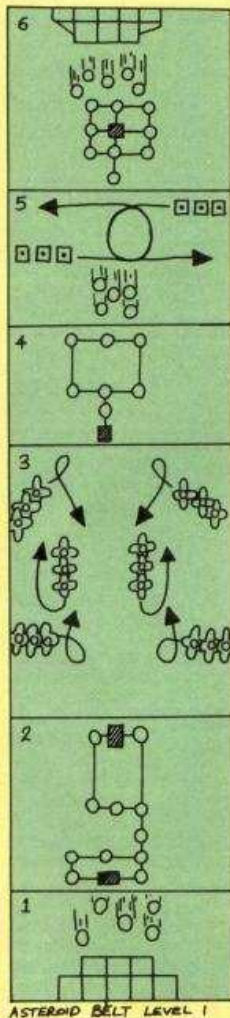

ASTEROID BELT LEVEL 1

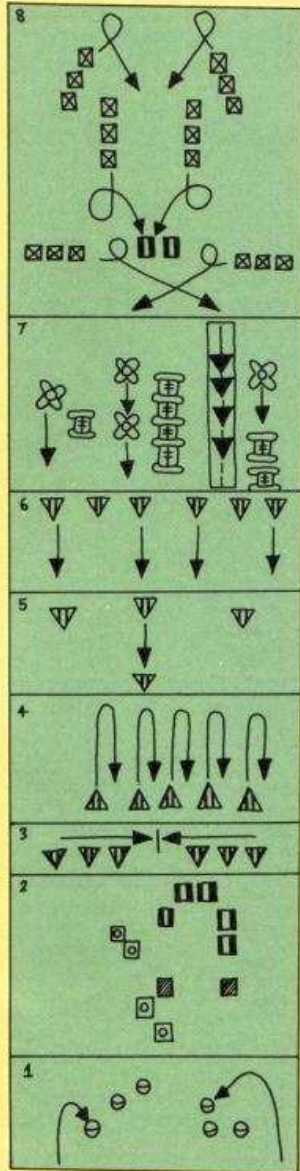

JUNGLE PLANET

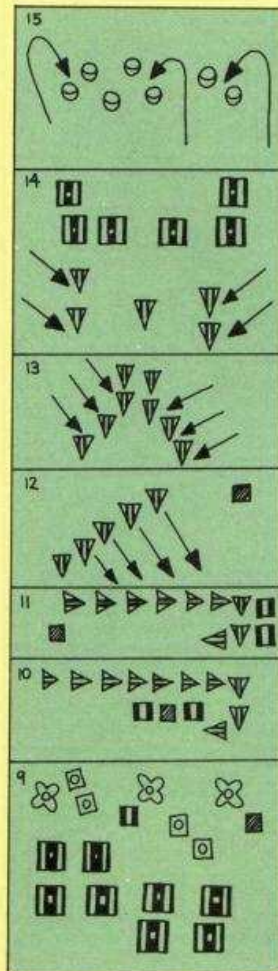

JUNGLE PLANET (CONTINUED)

JUNGLE PLANET KEY:

- - BOUNCING BALL
- - UNBLASTABLE ALIENS
- ▽ - ENEMY FIGHTER FIRES MISSILES AND BULLETS
- ⊞ - PART OF A GROUP (PODS)
- ▼ - FIGHTER ON RUNWAY
- ⊗ - ALIENS
- ⊞ - LOCATE LIFE

TO LOCATE EXTRA LIFE YOU BLAST EVERY ONE OF THESE, THEN SEE IF ONE CRATER HAS A FACE - IF SO, YOU'VE GAINED A LIFE.

- ⊞ - COMMAND CENTRE

ASTEROID BELT KEY:

- - ASTEROID
- ⊞ - PART OF A GROUP (PODS) (DESTROY THEM ALL FOR A BONUS)
- ⊗ - ALIENS
- ⊞ - MOVEMENT (WHEN ALIENS COMPLETE A MOVEMENT THEY FIRE)

NB: YELLOW ASTEROIDS FALL WHEN YOU ARE NEAR A COMMAND CENTRE, YOU MUST DODGE THESE. THEY CANNOT BE DESTROYED

LIGHTFORCE POKES

Those Incredibly Industrious Hackers from Haxby and Pocklington have cracked *Light Force*. I have to admit that I couldn't actually get these POKES to work with my version of the game but I think that's because I've got a pre-production copy. Anyway it's quite a short routine, so you won't waste too much time typing it in if it is defunct. These POKES make your ships totally

immune to anything the enemy cares to throw at you. If you don't want to cheat using pokes then there are some tips from The Mega Team from Stoke on Trent to help you out later on in the tips.

In case these POKES from the Haxby Hackers don't work here's another set of POKES from Stephen Thompson who lives in Cleveland. Both sets of

POKES do more or less the same thing.

```
10 REM C SMITH J BEAN D
AUSTIN
20 REM LIGHTFORCE POKES
30 CLEAR 24500
40 LOAD "" CODE
50 POKE 60406,21
60 POKE 60407,159
70 RANDOMIZE USR 60000
```

Here's Stephen's routine:

```
1 PAPER PI-PI: BORDER PI-PI
CLEAR VAL "24099": LOAD ""
CODE:LET a=VAL "60297":
POKE a,VAL "62": POKE a+PI/
PI, PI-PI: POKE a+VAL "2", VAL
"50"
2 POKE a+INT PI,VAL "21":
POKE a+VAL "4", VAL "159":
RANDOMIZE USR val "6e4"
Well, one of them must work!
```

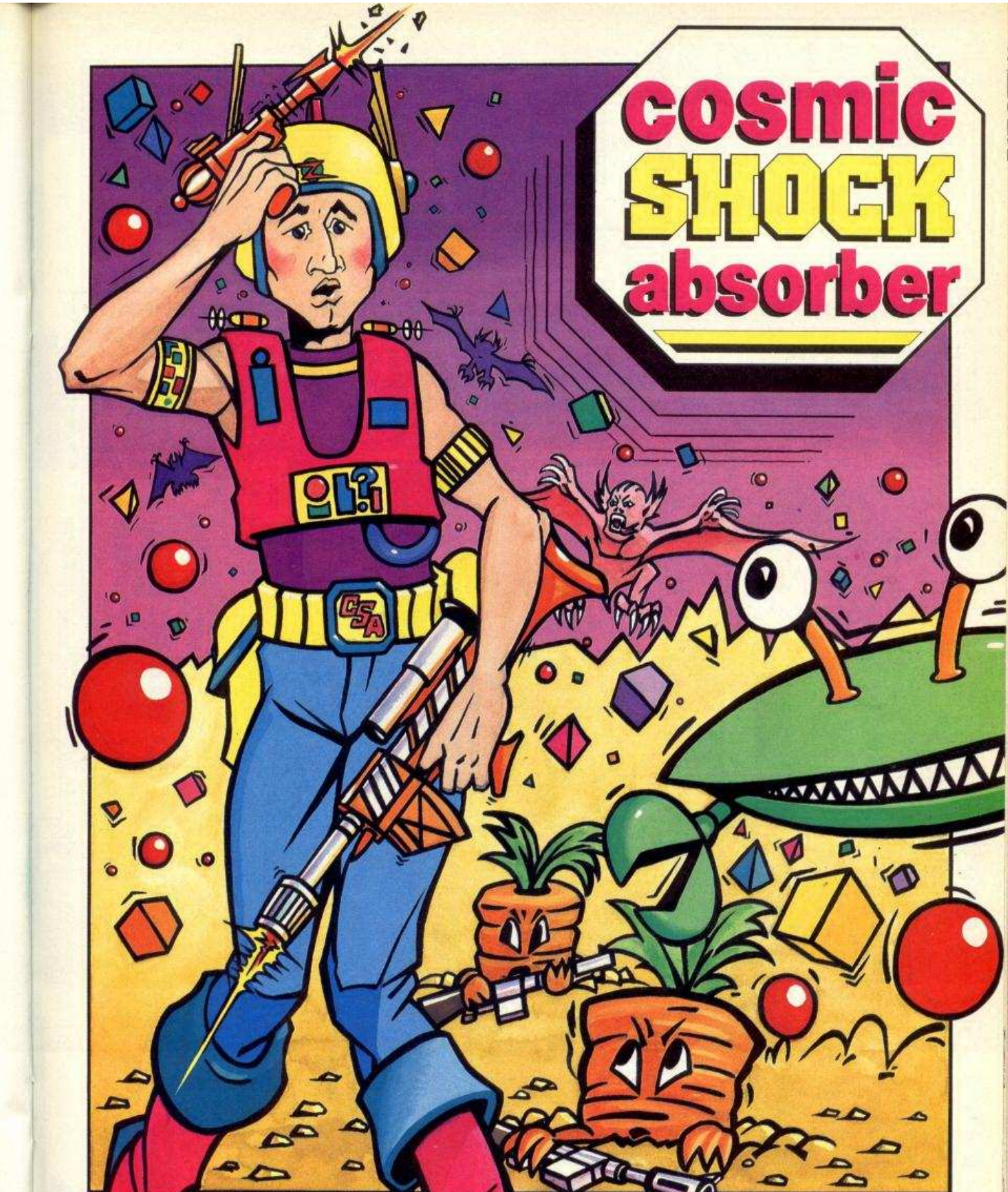
cosmic SHOCK absorber

YOU WON'T HAVE SEEN THE FILM . . . THERE IS
NO BOOK . . . NOW FIND OUT WHY!
(- IT'S 3D BLASTING FUN!!!)

Spectrum 48/128 Cassette £8.95 MSX Cassette £8.95
Amstrad 464/664/6128 Cassette £8.95 Disc £14.95
Commodore 64/128 Cassette £8.95 Disc £12.95

Available from all leading software retailers or order today by
mail. Prices include postage and packing plus VAT.

martech Martech is the registered trade mark of
Software Communications Limited, Martech House,
Bay Terrace, Pevensey Bay, East Sussex BN24 6EE
TRADE ENQUIRIES WELCOME. PHONE: (0323) 768456 TELEX: 878373 Martec G



BIG, BRIGHT, BOLD AND BRASH, LM IS DESTINED TO BREAK NEW GROUND IN YOUTH MAGAZINE PUBLISHING WHEN IT HITS THE STREETS EARLY NEXT YEAR. AN UNCOMPROMISING COCKTAIL OF HARD-HITTING FEATURES, INTERVIEWS AND REVIEWS, LM WILL BE HARD, TOUGH AND UTTERLY UNSTOPPABLE. YOU WON'T MISS IT.

LM is aimed mainly, though not exclusively, at 15-25 year-old males. Inside you'll find a fascinating and refreshing mixture of informative, entertaining and intelligent features on everything that's crucial for British youth in the lates 80s. Off-the-wall, off-the-peg, off-the-cuff and occasionally out of order.

LM — Possibly the best youth magazine concept ever. 'Vorsprung Durch Technik,' as they say in Ludlow.

- MUSIC
- VIDEOS
- FILM
- SPORT
- LEISURE
- CLOTHES
- TRAVEL
- HOLIDAYS
- SWOPSHOP
- AGONY
- CHARTS
- LETTERS
- PERSONALITIES
- EVENTS
- GAMES
- PURSUITS
- COMPUTERS
- BIKES
- CARS
- OPINIONS
- BOOKS
- THEATRE
- CARROTS
- OTHER VEGETABLES

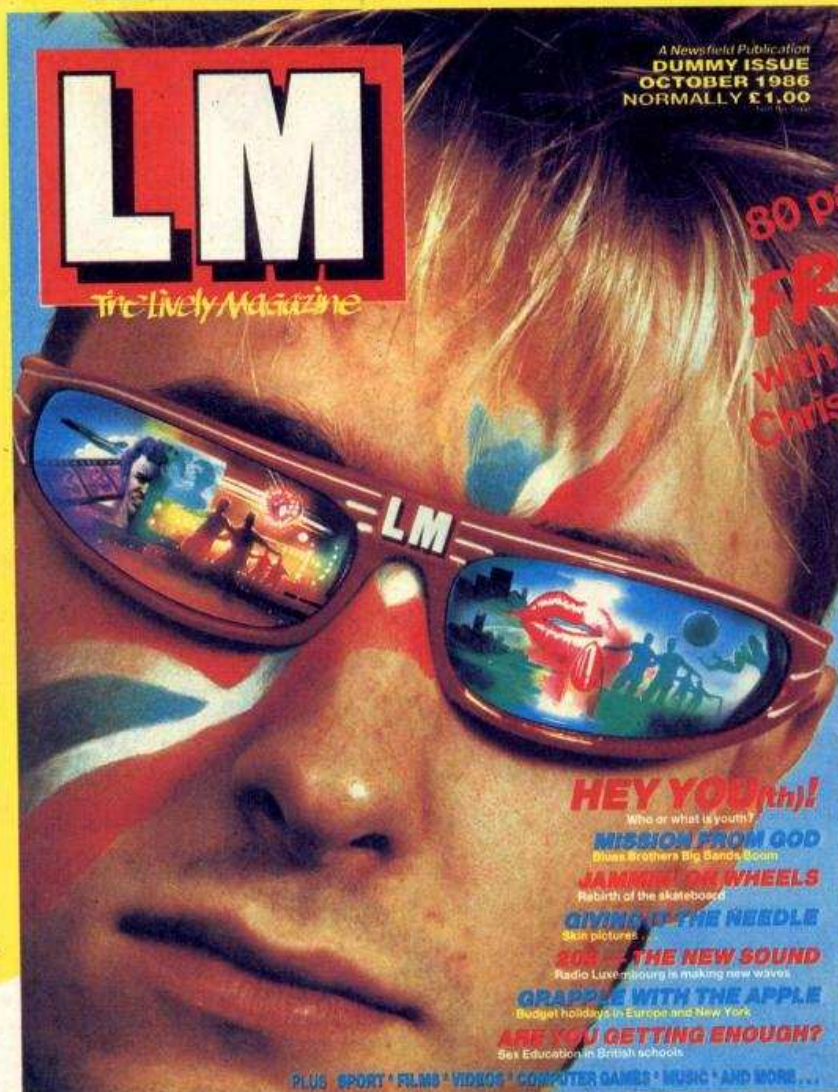

80 page Issue 0
FREE
with the
Christmas Special!

**AND
THEN**

Issue 1
ON Sale From
14th JANUARY
price
£1.00

Another riveting monthly from NEWSFIELD

BECOME A CITY SLICKER

If you know your way around London, We'll take you to see the Xmas lights!

Streets paved with copies of Hewson's latest smash



You may have heard on occasion that the life of a Competition Minion is not a happy one. No, well dear readers, take my word that I tell the truth. It is therefore always a pleasure to come across a few spare minutes in the day when I can escape from the flowery niff of girlie perfume and the raucous cacklings of pre-pubescent reviewers and settle down in a comfy corner to feed one of the latest Speccy games into my ever-hungry computer. Lately it's been dining on *City Slicker*, the latest game to be graced by the HEWSON label.

In the game you play the role of Slick who must defuse a bomb in the Houses of Parliament that has

been planted by the nefarious terrorist Abru Cadabba. He must do this by finding all the various parts of his Bomb Disposal Unit which are unfortunately scattered liberally around the city.

The plot does seem a little familiar. The CRASH team are not noted for their neatness and I always get the job of looking for their lost items. Girlie tipster Hannah Smiff is always sending me scuttling around in dark corners and searching through wastepaper baskets in an attempt to find lost lipsticks. Oh, would you be a lovey and look for it. I was given it in Paris and it's so.o.o expensive. The indignity of it all dear readers. Lee Paddon fares no

better either and has me scampering around looking for all his lost discs. I try to tell them that I'm a competition minion and not a lost property office but all to no avail. I've a good mind to send a letter to the Winchester Institute for Minion Powers (or W.I.M.P.S. for short) but I seem to have lost the address.

Ah well I suppose I could enter the HEWSON competition and try to win the first prize of an all expenses paid tour around London. See all the sights, have a hot dog from one of the Beefeater places but I'd never get the time off. There are 50 runner up prizes too of a copy of *City Slicker* too but I've already bought the game.

Why don't you enter dear readers, after all you only have to name the two London tube stations between Embankment and Oxford circus and name the two famous landmarks associated with them. Put your answers on the back of a postcard and send them to City Slicker, CRASH Towers, Po Box 10, Ludlow, Shropshire, SY8 1DB to arrive here no later than 31st of December. The first correct answer drawn out of the publishing executive type Guchi Snake Skin Doc Marten's gets to go on a whirlwind tour of the big smoke with the luvverly Julia from HEWSON, and perhaps even the Girlie tipster if tips fans will give her some rest from their relentless poking.

TOP THIRTY FOR DECEMBER

This month sees PAPERBOY zoom into the charts and firmly delivered into the number two slot for Elite. Will it make the news next month by topping the number 1 GHOSTS AND GOBLINS also from Elite? Perhaps, but with five other new entries in the charts we say goodbye to CYBERUN, STARSTRIKE II, SPINDIZZY, BOUNDER, BACK TO SKOOL and PENTAGRAM and hello to LIGHTFORCE at the number 16 slot for FTL in and DAN DARE who fights the Mekon at number 17 for Virgin. Domark have two games in the charts at 23 and 24, a jumble of SPLIT PERSONALITIES and TRIVIAL PURSUITS. Odin's HEARTLAND shows a sign of life in the number 27 slot and the UNIVERSAL HERO of Mastertronic watches for attacks from the flank in the 30th position.

Andrew Green of Walsall should be getting £40's worth of freebie software in time to update his software crissy presents list into the very latest. Spectrum games as the winner of the Hotline Draw this month. Four lucky runners up will each receive a CRASH T Shirt and Hat in time to afford them the very meagrest of protection from those winter chills. The lucky four are: Martin Bell of County Down; Stacey Elliot of Swindon; R Harris of Surrey and Spencer Gore who lives in bloody (geddit?) Berks.

The HOTLINE AND ADVENTURE CHART compiled from the votes of CRASH readers is the most realistic chart for gauging the popularity of Spectrum games — it is the games that are being played that get the votes, not the games that are in the shops this week or month.

And the votes are important, it's up to you to let us know what you feel, so fill in the voting forms that live on the Results pages and make your voice heard. Well, make your writing readable — there's no longer a phoneline voting service.

If you don't want to carve up your copy of CRASH, we understand. Use a photocopy if you like, or copy out the details from the voting forms onto a nice clean sheet of paper and send that to us instead.

Apart from the satisfaction of registering your opinion, there's always the chance of winning a rather interesting prize. Once the information has been taken from the forms we receive during the course of the month, ten voting slips are drawn out for special consideration by Auntie Aggie — five from the Adventure Ballot Box and five from the Hotline Ballot Box.

A top prize of £40 worth of software (your choice, not ours) and a CRASH T Shirt is awarded to the first slip out of the draw from the Hotline votes, and another £40 worth of goodies and a Shirt goes to the Hotline Draw winner.

Four runners up from each ballot collect a CRASH T Shirt and a CRASH Hat, so get those votes in to the CRASH HOTLINE and CRASH ADVENTURE TRAIL, PO BOX 10, LUDLOW, SHROPSHIRE, SY8 1DB.

Hotline Top 30

1 (1)	GHOSTS AND GOBLINS	ELITE
2 (-)	PAPERBOY	ELITE
3 (4)	COMMANDO	ELITE
4 (7)	ELITE	FIREBIRD
5 (5)	BOMB JACK	ELITE
6 (2)	QUAZATRON	HEWSON
7 (8)	MATCHDAY	OCEAN
8 (3)	JACK THE NIPPER	GREMLIN GRAPHICS
9 (6)	BATMAN	OCEAN
10 (9)	GREEN BERET	IMAGINE
11 (16)	DYNAMITE DAN II	MIRRORSOFT
12 (10)	BOBBY BEARING	THE EDGE
13 (27)	STARQUAKE	BUBBLE BUS
14 (23)	TURBO ESPRIT	DURELL
15 (28)	LORDS OF MIDNIGHT	BEYOND
16 (-)	LIGHTFORCE	FTL
17 (-)	DAN DARE	VIRGIN
18 (12)	MOVIE	IMAGINE
19 (-)	SABOTEUR	DURELL
20 (17)	PING PONG	IMAGINE
21 (22)	STAINLESS STEEL	MIKRO-GEN
22 (13)	SPELLBOUND	MASTERTRONIC
23 (-)	SPLIT PERSONALITIES	DOMARK
24 (-)	TRIVIAL PURSUITS	DOMARK
25 (26)	EXPLODING FIST	MELBOURNE HOUSE
26 (18)	HEAVY ON THE MAGICK	GARGOYLE GAMES
27 (-)	HEARTLAND	ODIN
28 (11)	KNIGHT TYME	MASTERTRONIC
29 (19)	HYPERSPORTS	IMAGINE
30 (-)	UNIVERSAL HERO	MASTERTRONIC

The adventure chart sees **HEAVY ON THE MAGICK** still weaving its number 1 spell for Gargoyle Games whilst **CRL**, **THE BOGGIT** moves up to take second place. The highest new entry **MINDSTONE** just makes it to the top ten for The Edge. Dashing into the charts this month are **ENIGMA FORCE** from Beyond at number 15, Activision's **MINDSHADOW** in at 22 while **VALHALLA** re-enters in the 23rd position. **MAFIA CONTRACT II** from Atlantis bullies its way into the charts at the thirtieth position. That's all for this month, so for all you chart watchers don't forget to send in your vouchers and have the chance to win £40's worth of software or a CRASH Hat and T Shirt each month in **THE CRASH CHARTS**.

The winner of this month's Adventure Draw has the very unlikely name of Charlotte Chipcase. I always thought a chipcase was the outside of a Spectrum. Still I bet she knows all the terrible jokes and will laugh all the way to her Spectrum when she collects forty quids worth of fun to plug into her computer. Well done to her and also to the four runners up who will soon be emblazoned with CRASH memorabilia, namely T Shirts and Hats, which will go to: David Armstrong of Alloa, R Welsh of Bristol; Neil McI Dowall of Salisbury and Brian Neilson who's from Lanarkshire.

Adventure Top 30

1 (1)	HEAVY ON THE MAGICK	GARGOYLE GAMES
2 (8)	THE BOGGIT	CRL
3 (4)	LORDS OF MIDNIGHT	BEYOND
4 (3)	SPELLBOUND	MASTERTRONIC
5 (2)	KNIGHT TYME	MASTERTRONIC
6 (12)	FAIRLIGHT	THE EDGE
7 (5)	LORD OF THE RINGS	MELBOURNE HOUSE
8 (6)	THE HOBBIT	MELBOURNE HOUSE
9 (9)	DOOMDARK'S REVENGE	BEYOND
10 (-)	MINDSTONE	THE EDGE
11 (11)	PRICE OF MAGIK	LEVEL 9
12 (27)	DRAGONTORC	HEWSON
13 (7)	FOURTH PROTOCOL	CENTURY/HUTCHINSON
14 (24)	TIR NA NOG	GARGOYLE GAMES
15 (-)	ENIGMA FORCE	BEYOND
16 (17)	SHADOWFIRE	BEYOND
17 (20)	RED MOON	GARGOYLE GAMES
18 (25)	REDHAWK	MELBOURNE HOUSE
19 (15)	BORED OF THE RINGS	SILVERSOFT
20 (16)	DUN DARACH	GARGOYLE GAMES
21 (18)	SWORDS AND SORCERY	PSS
22 (-)	MINDSHADOW	ACTIVISION
23 (-)	VALHALLA	LEGEND
24 (13)	SEA BASE DELTA	FIREBIRD
25 (22)	SHERLOCK	MELBOURNE HOUSE
26 (21)	MARSPORT	GARGOYLE GAMES
27 (23)	GREMLINS	ADVENTURE INTERNATIONAL
28 (-)	SPIDERMAN	ADVENTURE INTERNATIONAL
29 (-)	SUBSUNK	FIREBIRD
30 (-)	MAFIA CONTRACT II	ATLANTIS

CRASH CHARTS



lan Craig

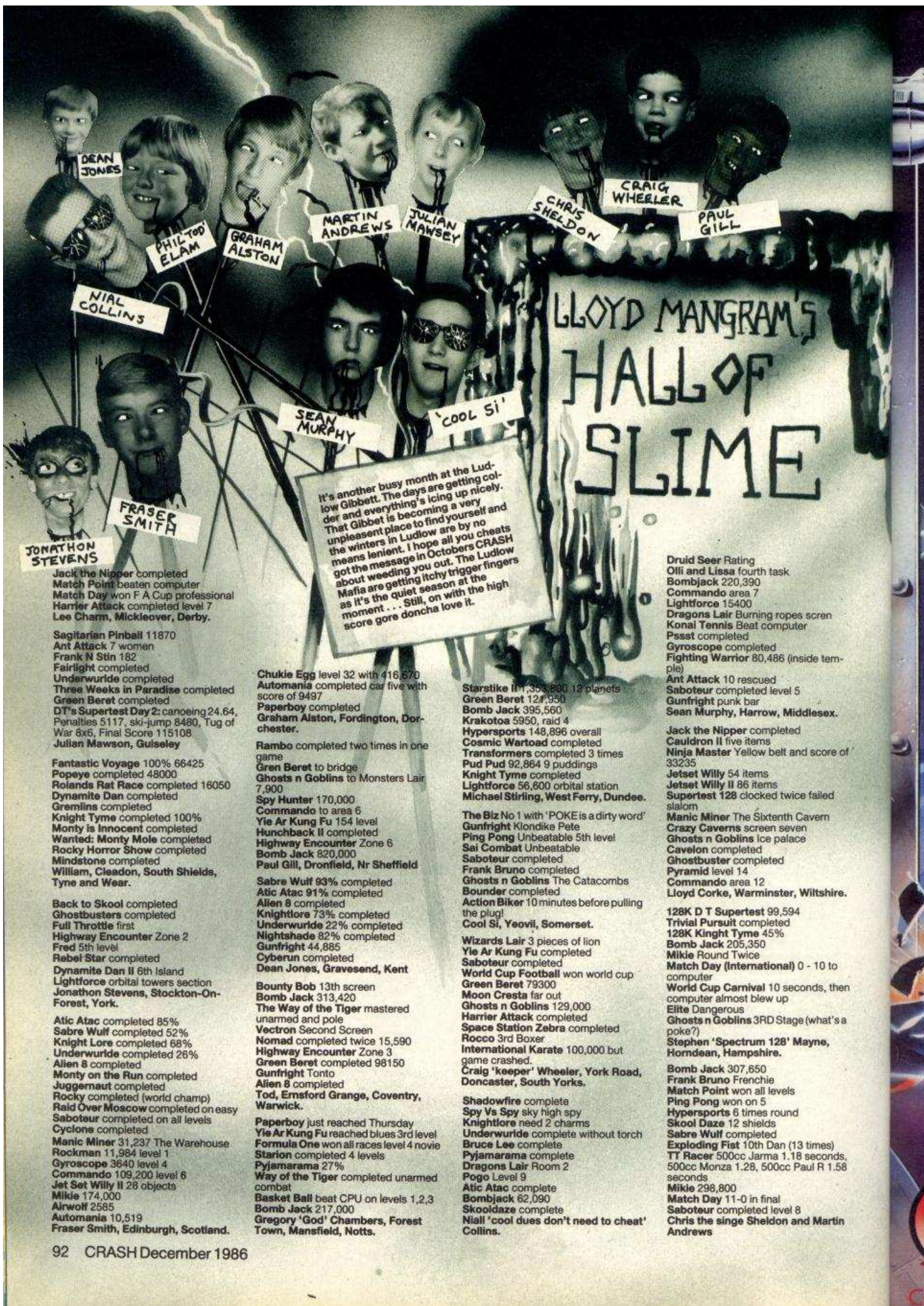

LLOYD MANGRAM'S HALL OF SLIME

It's another busy month at the Ludlow Gibbet. The days are getting colder and everything's icing up nicely. That Gibbet is becoming a very unpleasant place to find yourself and the winters in Ludlow are by no means lenient. I hope all you cheats got the message in Octobers CRASH about weeding you out. The Ludlow Mafia are getting itchy trigger fingers as it's the quiet season at the moment... Still, on with the high score gore doncha love it.

Jack the Nipper completed Match Point beaten computer Match Day won F A Cup professional Harrier Attack completed level 7 Lee Charm, Mickleover, Derby.

Sagitarian Pinball 11870
Ant Attack 7 women
Frank N Stin 182
Fairlight completed
Underwulde completed
Three Weeks in Paradise completed
Green Beret completed
DT's Supertest Day 2: canoeing 24.64,
Penalties 5117, ski-jump 8480, Tug of
War 8x6, Final Score 115108
Julian Mawson, Guiseley

Fantastic Voyage 100% 66425
Popeye completed 48000
Rolands Rat Race completed 16050
Dynamite Dan completed
Gremlins completed
Knight Tyme completed 100%
Monty is Innocent completed
Wanted: Monty Mole completed
Rocky Horror Show completed
Mindstone completed
William, Cleadon, South Shields,
Tyme and Wear.

Back to Skool completed
Ghostbusters completed
Full Throttle first
Highway Encounter Zone 2
Fred 5th level
Rebel Star completed
Dynamite Dan II 6th Island
Lightforce orbital towers section
Jonathon Stevens, Stockton-On-
Forest, York.

Atic Atac completed 85%
Sabre Wulf completed 52%
Knight Lore completed 68%
Underwulde completed 26%
Alien 8 completed
Monty on the Run completed
Juggernaut completed
Rocky completed (world champ)
Raid Over Moscow completed on easy
Saboteur completed on all levels
Cyclone completed
Manic Miner 31,237 The Warehouse
Rockman 11,984 level 1
Gyroscope 3640 level 4
Commando 109,200 level 6
Jet Set Willy II 28 objects
Mikie 174,000
Airwolf 2585
Automania 10,519
Fraser Smith, Edinburgh, Scotland.

Chukie Egg level 32 with 416,870
Automania completed car five with
score of 9497
Paperboy completed
Graham Alston, Fordington, Dor-
chester.
Rambo completed two times in one
game
Green Beret to bridge
Ghosts n Goblins to Monsters Lair
7,900
Spy Hunter 170,000
Commando to area 6
Yie Ar Kung Fu 154 level
Hunchback II completed
Highway Encounter Zone 6
Bomb Jack 820,000
Paul Gill, Dronfield, Nr Sheffield

Sabre Wulf 93% completed
Atic Atac 91% completed
Alien 8 completed
Knightlore 73% completed
Underwulde 22% completed
Nightshade 82% completed
Gunflight 44,885
Cyberun completed
Dean Jones, Gravesend, Kent

Bounty Bob 13th screen
Bomb Jack 313,420
The Way of the Tiger mastered
unarmed and pole
Vectron Second Screen
Nomad completed twice 15,590
Highway Encounter Zone 3
Green Beret completed 98150
Gunflight Tonto
Alien 8 completed
Tod, Ermsford Grange, Coventry,
Warwick.

Paperboy just reached Thursday
Yie Ar Kung Fu reached blues 3rd level
Formula One won all races level 4 novice
Starion completed 4 levels
Pyjamarama 27%
Way of the Tiger completed unarmed
combat
Basket Ball beat CPU on levels 1,2,3
Bomb Jack 217,000
Gregory 'God' Chambers, Forest
Town, Mansfield, Notts.

Starstike II 1,353,800 12 planets
Green Beret 124,950
Bomb Jack 395,560
Krakotoa 5950, raid 4
Hypersports 148,896 overall
Cosmic Warload completed
Transformers completed 3 times
Pud Pud 92,864 9 puddings
Knight Tyme completed
Lightforce 56,600 orbital station
Michael Stirling, West Ferry, Dundee.

The Biz No 1 with 'POKE is a dirty word'
Gunflight Klondike Pete
Ping Pong Unbeatable 5th level
Sai Combat Unbeatable
Saboteur completed
Frank Bruno completed
Ghosts n Goblins The Catacombs
Boulder completed
Action Biker 10 minutes before pulling
the plug!
Cool Si, Yeovil, Somerset.

Wizards Lair 3 pieces of lion
Yie Ar Kung Fu completed
Saboteur completed
World Cup Football won world cup
Green Beret 79300
Moon Cresta far out
Ghosts n Goblins 129,000
Harrier Attack completed
Space Station Zebra completed
Rocco 3rd Boxer
International Karate 100,000 but
game crashed.
Craig 'keeper' Wheeler, York Road,
Doncaster, South Yorks.

Shadowfire complete
Spy Vs Spy sky high spy
Knightlore need 2 charms
Underwulde complete without torch
Bruce Lee complete
Pyjamarama complete
Dragons Lair Room 2
Pogo level 9
Atic Atac complete
Bombjack 62,090
Skool Daze complete
Niall 'cool dues don't need to cheat'
Collins.

Druid Seer Rating
Olli and Lissa fourth task
Bombjack 220,390
Commando area 7
Lightforce 15400
Dragons Lair Burning ropes scen
Konai Tennis Beat computer
Passt completed
Gyroscope completed
Fighting Warrior 80,486 (inside tem-
ple)
Ant Attack 10 rescued
Saboteur completed level 5
Gunflight punk bar
Sean Murphy, Harrow, Middlesex.

Jack the Nipper completed
Cauldron II five items
Ninja Master Yellow belt and score of
33235
Jetset Willy 54 items
Jetset Willy II 86 items
Supertest 128 clocked twice failed
slalom
Manic Miner The Sixteenth Cavern
Crazy Caverns screen seven
Ghosts n Goblins Ice palace
Cavelon completed
Ghostbuster completed
Pyramid level 14
Commando area 12
Lloyd Corke, Warminster, Wiltshire.

128K D T Supertest 99,594
Trivial Pursuit completed
128K Knight Tyme 45%
Bomb Jack 205,350
Mikie Round Twice
Match Day (International) 0 - 10 to
computer
World Cup Carnival 10 seconds, then
computer almost blew up
Elite Dangerous
Ghosts n Goblins 3RD Stage (what's a
poke?)
Stephen 'Spectrum 128' Mayne,
Horndean, Hampshire.

Bomb Jack 307,650
Frank Bruno Frenchie
Match Point won all levels
Ping Pong won on 5
Hypersports 6 times round
Skool Daze 12 shields
Sabre Wulf completed
Exploding Fist 10th Dan (13 times)
TT Racer 500cc Jarma 1.18 seconds,
500cc Monza 1.28, 500cc Paul R 1.58
seconds
Mikie 298,800
Match Day 11-0 in final
Saboteur completed level 8
Chris the singe Sheldon and Martin
Andrews

WHEN MERE MAN WAS NOT ENOUGH...
IT WAS THE TIME OF...

CYBORG



CRI

Hot Line: 01-533 2918

CRI Group PLC, CRI House 9 Kings Yard, Carpenters Road London E15 2HD

DANDY



SPECTRUM SCREENS

Dandy is the massive arcade adventure that takes you through some of the most detailed dungeons you've ever seen. Either solo or with a (brave) friend you can hack, thump and zap your way through spectres, necromancers and other dungeon-dwellers whose concern for your health and well-being is zero.

They have their reasons of course. They're guarding a massive treasure hoard which you, if you're quick, can stuff into your amazingly capacious swag bag.

Dandy is the ultimate dungeon. Enter at your peril!

FEATURES

- 3 complete 5-level dungeons
- Treasure trove screens at the end of each dungeon
- One or two players
- 5 different spell types
- A variety of nasties
- Frenzied, thumb-busting action

AVAILABLE ON:

ZX Spectrum 48K/128K/ + cassette...£7.99
Coming soon for Amstrad and Commodore home computers

Electric Dreams

SOFTWARE

ELECTRIC DREAMS SOFTWARE
31 CARLTON CRESCENT, SOUTHAMPTON
SO1 2EW TEL: (0703) 229694

Mail Order: Electric Dreams Software,
23 Pond Street, Hampstead,
London NW3 2PN.

EXPLORER

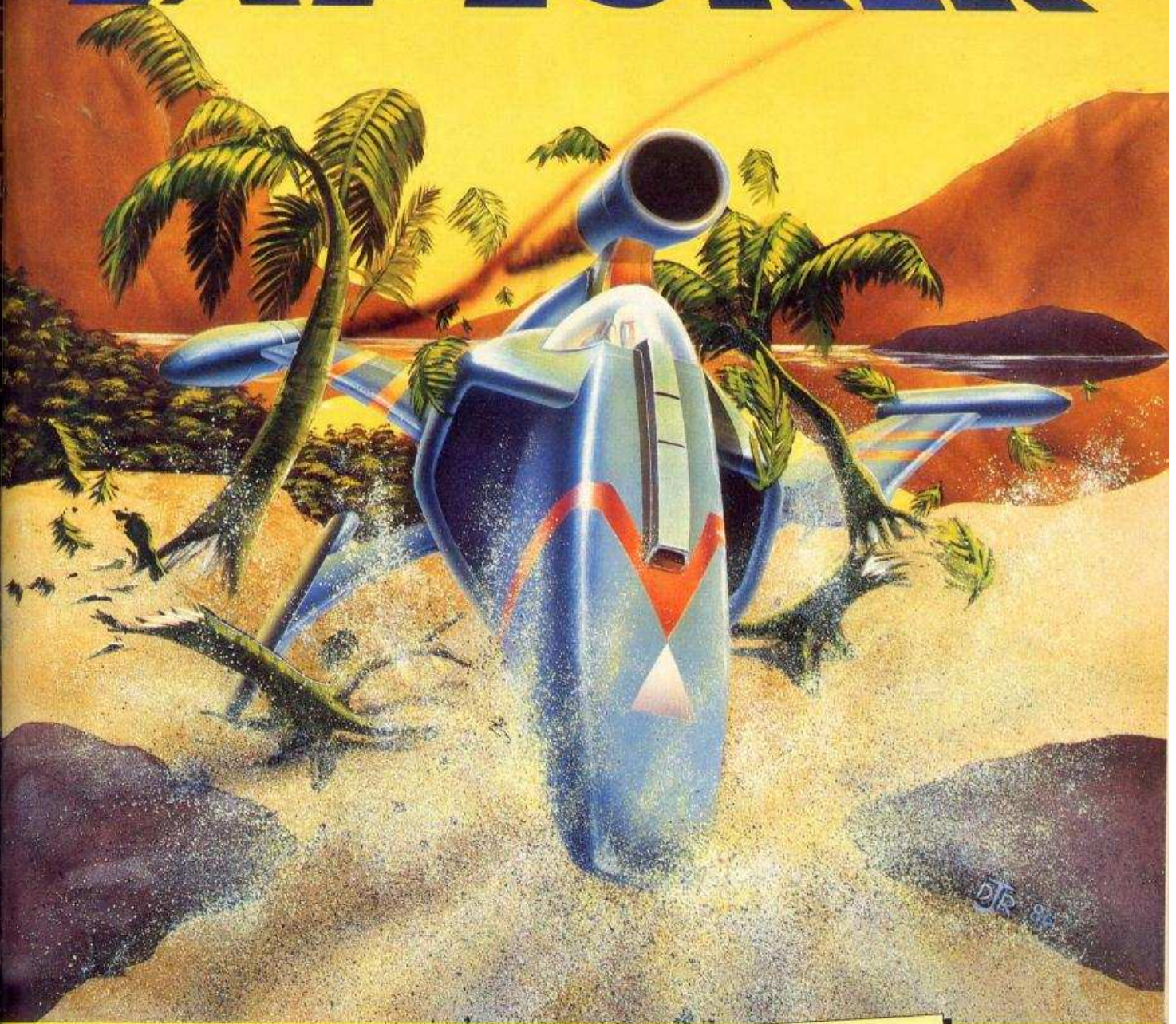

Aaargh. Something just woke you from a cryogenic sleep right in the middle of your favourite dream.

Your ship has dropped out of warp and you are forced to make a glide-in landing on a very strange looking jungle planet. Equipped with jet pack for flying, navigation and weapons systems, fight your way through the jungle taking on it's strange and none-too-pleasant inhabitants. Only by finding vital parts stripped in your ship's unscheduled descent can you ever hope to escape.

Explorer is huge. There are literally billions of views and an enormous scrolling map.

If you ever wanted to get lost in a simulation this is the one to do it in.

FEATURES

- 4 way scrolling landscape
- 40 billion graphic locations
- Inertial navigation system
- Rotovision™ animated landscape
- 360 degree views

AVAILABLE ON:

ZX Spectrum 48K/128K/ + cassette...£7.99
Coming soon for Amstrad and Commodore home computers

Electric Dreams

SOFTWARE



SPECTRUM SCREENS

THEY \$TOLE A MILLION



“Plan the Robbery of a Lifetime!”

Commodore 64/128 (cassette £9.95, disk £14.95)
Amstrad 464/664/6128 (cassette £8.95, disk £14.95)
Spectrum 48/128 (cassette £8.95)

OUT THIS MONTH

Marketed & Distributed by
© 1986 Ariolasoft UK Ltd

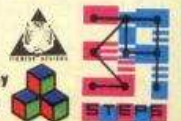

AVAILABLE FROM ALL GOOD SOFTWARE RETAILERS - IF IT'S NOT THERE, PLEASE ORDER IT - OR IN THE CASE OF DIFFICULTY SEND YOUR CROSSED CHEQUE/P.O. MADE OUT TO ARIOLASOFT UK LTD, INCLUDING YOUR OWN NAME AND ADDRESS, TO ARIOLASOFT, P.O. BOX 461, LONDON NW1 2ND

**SUPER HERO KIT WITH ZOOM BINOCULARS
AND COMPACT 35MM CAMERA UP FOR GRABS**

**DRESS HANNAH AND BE A
DO-IT-YOURSELF SUPERHERO**
(and probably get your hands slapped)

The end of the world is in sight. The very fabric of reality is tearing and already strange things are beginning to happen. The cracked cosmos has given birth to bouncing balls and rampaging hordes of machine gun carrying carrots - or is that carrot carrying machine guns? Who cares; it will all be totally academic unless someone can save the universe. But who will answer the cries of a doomed humanity and repel the offworld oppressors? No-one can contact Batman or his gardener and Superman's hands are tied up with Hannah (Lois) Smiff. This seems like a job for ... *Cosmic Shock Absorber* ... Yes citizen, in **MARTECH'S** latest game, you become a forth rate super hero, resplendent in pink and green boots, purple T shirt, blue boots and yellow crash helmet as you try to save the universe from the ravages of complete madness and good dress sense.

You too could win the chance to don lurid lycra and pull on your satin knickers - over the trousers naturally - in the **MARTECH** *Cosmic Shock Absorber Competition* where the winner will receive their very own DIY superhero kit. Fifty runners up will receive a copy of the game with which to grace their software collection.

All you have to do is to lend a hand to our very own Girlie Tipster Hannah Smiff who would quite like to demand the undivided attention of her Ludlothian Superman who she met in Ludlow's very own Stringfellows just the other night. To win your very own DIY superhero kit you must design the ultimate girlie superhero garb with which to impress any passing superhero.

To make it a little easier for you Hannah has been faithfully reproduced in cartoon form by the bods in art, (it's easier to make a cartoon of real tipsters than to make cartoons into real tipsters). Get out your pens, crayons and felts tips and clothe Hannah in the splendiferous garbs that any supertipster truly deserves. Once your designer creation is finished, pop it into a sequinned envelope and post it to **The Truly Magnificent Hannah Smiff, Crash, PO BOX 10, Ludlow, Shropshire, SY8 1DB** to arrive here before the 31st of December.

**50 COPIES
OF COSMIC
SHOCK
ABSORBER
MUST BE
WON!**

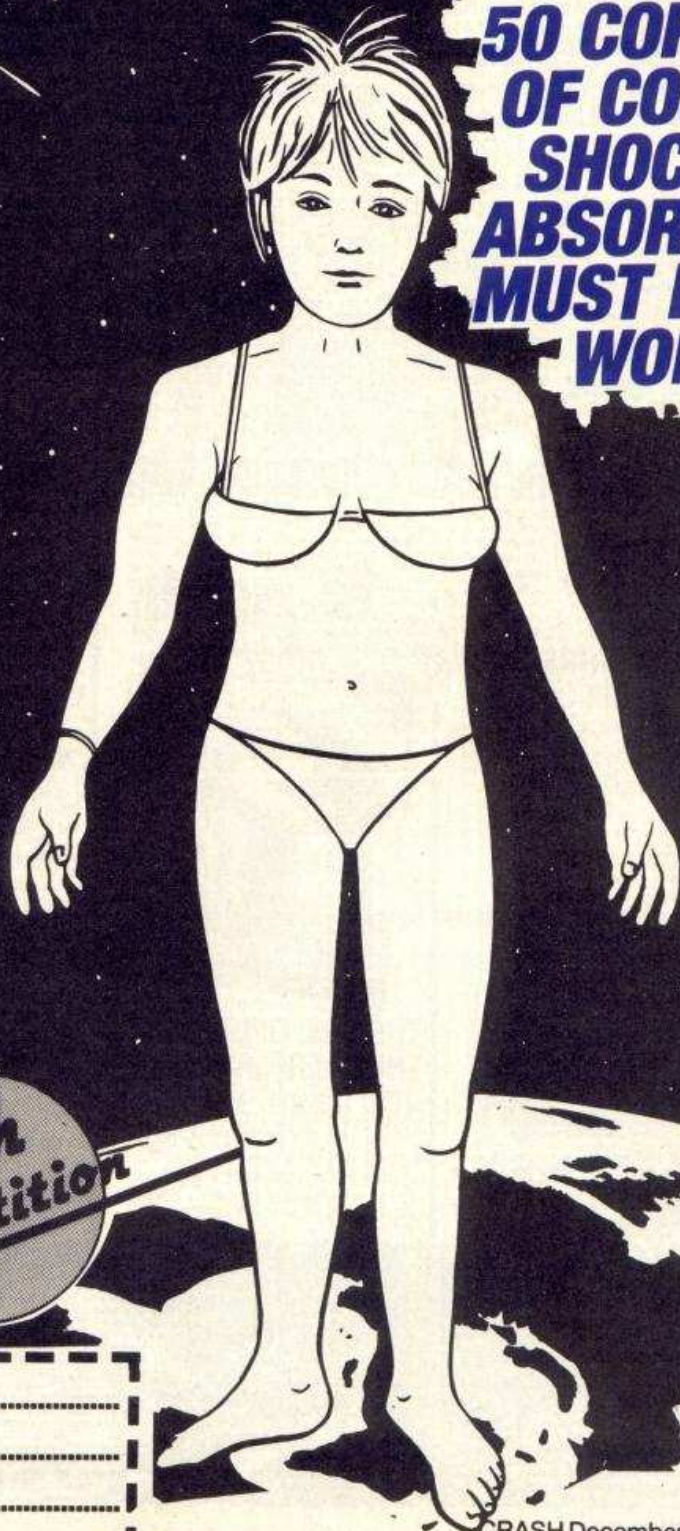

**Crash
Competition**

NAME

ADDRESS

.....

.....

POST CODE

The 1st choice
**EXPRESS SPECTRUM, BBC
 and COMMODORE REPAIRS!**

**FREE
 GAMES WORTH £39
 WITH EVERY REPAIR***

**WHY PAY HIGH
 'FIXED'
 PRICES**

Spectrum
 repairs between
 £9 and £20.

BBC repairs
 between
 £14 and £45.

Commodore
 repairs between
 £14 and £35.

*Spectrum, only

(We do not charge you for our fancy premises by charging high 'fixed' prices!)

Reputations take time to build, we have been repairing ZX 81's, Spectrums, QL's, Apples and BBC's professionally, for 2 1/2 years - who is coming second?

In all U.K. with While-u-Wait repairs! with INTERNATIONAL repair service!

to charge LOW PRICES for the smaller repairs! (e.g. £9 for keyboard faults)

FOR LOW PRICES - "My computer blew recently, I took it to MANCOMP, who fixed it in 8 minutes! and for less than £10! They are local, 'clued up', and blindingly efficient!" 4 HEATONS DIGEST.

FOR PROFESSIONALISM - "Of all the repair companies 'Sinclair User' spoke to, MANCOMP seemed the MOST PROFESSIONAL when it came to advice and a helpful attitude" AUG 85.



FOR HONESTY - We let you watch your computer being repaired and if there is nothing wrong with it, we will tell you!!



FOR REPUTATION & HELPFULNESS - "I have come across a firm that will be more than willing to advise you as to how to remedy your problems. They are called MANCOMP and as well as repairing faulty computers, are also quite willing to discuss your problems with you and offer reasonably cheap and more importantly CORRECT CURES" Phil Rogers POPULAR COMPUTING WEEKLY JAN 85.



FOR SPEED - "One firm at least can effect any necessary repairs over the counter in 45 minutes. Based in Manchester, MANCOMP can offer what is arguably the FASTEST turnaround in the business to personal callers" CRASH Magazine JUNE 1985.



THIS IS WHY Spectrum users from London, Cornwall, Scotland, Birmingham, Liverpool, Coventry, Leicester, Glossop, I.O.M., etc. AUSTRALIA, AUSTRIA, BELGIUM, EGYPT, EIRE, GERMANY, HOLLAND, KUWAIT, NORWAY, PAKISTAN, PAPUA

NEW GUINEA, SAUDI ARABIA, SWEDEN, SWITZERLAND and ZIMBABWE - send their Spectrums to MANCOMP for repair!

24 HR. TURNAROUND NO-QUIBBLE GUARANTEE NO HIDDEN COSTS.

Because we repair hundreds of computers every week, we are able to pass on our 'component-buying discount' to YOU in lower prices... Z80A cpu £1.50, 4116 50p, Upgrade fitted £18.95

- we bring down the prices for repairs and components! (We may refuse to revive computers suffering from attempted D.I.Y. repairs!)

Every parcel sent by Royal Mail Receipted Post and insured for return journey! (For next day delivery include £1.50 extra).

(Securicor by prior arrangement). On-site maintenance for Apples, I.B.M.'s and most makes of printers also available.

Guaranteed 4hr response! WHY DELAY - OUR ESTIMATES ARE FREE AND WITHOUT OBLIGATION. IF

YOU DO NOT LIKE OUR ESTIMATE WE WILL RETURN THE COMPUTER AND REFUND THE POSTAGE INCURRED



MANCOMP LTD
 (Dept. C12)

Printworks Lane, Levenshulme, Manchester M19 3JP
 Phone 061-224 1888.

OR 061-224 9888.

OPEN MON - SAT 9am to 7pm



What we do today... others do tomorrow!

NOTE OUR PRICES AND WATCH OTHERS FOLLOW THE LEADER

**LATEST
 RELEASE**

**TERRESTIAL
 ENCOUNTER**

The big action game for space freaks everywhere!

£14.99 ATARI 520 ST FROM

**Solar
 SOFTWARE**

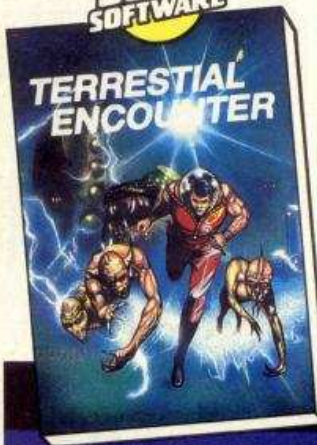

**THE FIRST
 EVER SUPER
 SPARKLER**

**THE SAS:
 OPERATION
 THUNDERFLASH!**

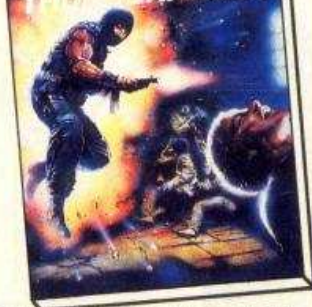

**THE SAS: OPERATION
 THUNDERFLASH!**

The first ever Super Sparkler! Only £2.99 for a super 3-D graphic game. Your task as leader of the SAS squad is to spearhead an offensive against the terrorists who have occupied a foreign embassy. Can you stay the pace? Spectrum 48k



**Spike Sparkler's
 pick of the hits
 at only £1.99 each
 Street Date 31 Oct.**

Poor old Santa! He's overslept again and now has only 5 hours to deliver all his Christmas goodies. Help him sort out this chaos by collecting and dropping the gifts down the right chimneys. SOON ON C-64 AND ATARI SPARKLE RATING*****

**SPECIAL
 DELIVERY**

SPECTRUM 48k

**MONKEY
 MAGIC**

C-64

Fast and furious with more than a dash of magic. This search for the holy scriptures involves battles with venomous creatures which you have to fend off with lightning bolts. SPARKLE RATING*****

**ORC
 ATTACK**

SPECTRUM 48k

Defend the castle against the hordes. As Eric the Brave you have to fight off waves of murderous Orcs, outwit and slay the evil Sorcerer, and defeat the gigantic Demon Trolls. Six play levels. SOON ON C-64 AND ATARI SPARKLING RATING*****

THE LATEST FROM SPARKLER'S ALSO INCLUDES:
 RIVER RESCUE ON C-64 TANK COMMANDER ON ATARI COMPUTER WAR ON ATARI

AVAILABLE FROM ALL GOOD SOFTWARE STORES

Unit B11, Armstrong Mill, Summit Centre, Southwood, Farnborough, Hants. GU14 0NP. Tel: 0252 522200.



WINNERS & PRIZES



JEFF MINTER

IS

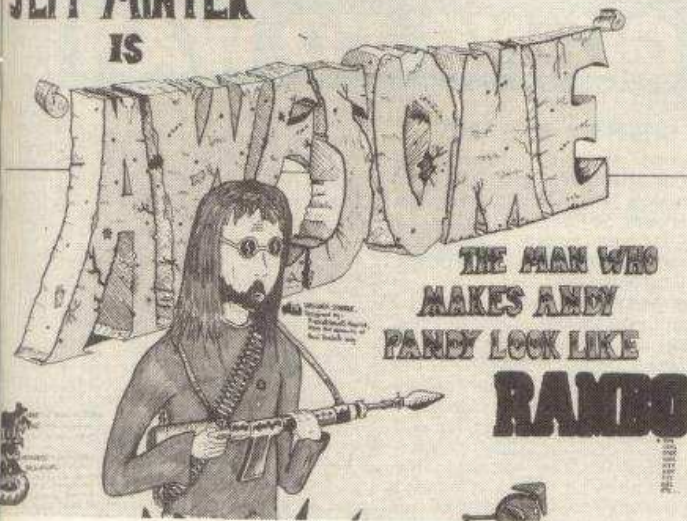

MINSON SPOTTING

PIRANHA asked you all to try to spot the Minson, as they too have great difficulty in finding our roving reporter unless they offer him some form of bribery or corruption (usually a free nosh accompanied by the odd Bloody Mary).

Well, his digital disguise may have fooled some people, but it didn't get past many of you. Two Minson Spotters win a chance to spot some of the CRASH staffers with red paint during their day out playing soldiers. They are **Richard Jones**, of White Dirt Lane, PO8 0TZ, and **Nigel Palmer**, of Glenalmond NR4 6AG.

It looks like PIRANHA are set to make a complete day of it — another comp in the Christmas Special will sort out a few more winners, and then a veritable army of CRASH, ZZAP! and AMTIX readers and staffers will nip off to the Combat Zone HQ next year for a big shoot-out!

Meanwhile, fifty copies of *Strike Force Cobra* should be on their way to:

Jonathon Tan, Old Smithy Lane, WA13 ONP; Ian Gillibrand, Bushbys Lane, L37 2QZ; Chris Docherty, Wingate Close, DH4 5QS; J Singh, Manor Road, TF1 4PN; D A Shotbolt, Lowther Road, LU6 3LQ; Gavin Burr, Stratford Road, CV34 8BQ; Robert Gabriel, Highland Terrace, EX15 3EW; Scott Fletcher, Rokeby Road, S59 9FU; Stephen Grant, Osbourne Road, BN1 6LP; Antony Chaplin, Louth Road, DN33 2JU; Ian King, Foyard Road, DY4 8BH; Richard Anderson, Kincora Avenue, Northern Ireland; Matthew Bond, Hewish Road, N18 1PS; David Clark, Arnheim Road, SO1 8LU; Judy Falkner, Glenmore Road, TNG 1TN; Philip Corrigan, Eastbourne Way, DN33 2PH; Jade Murray, Buckerfills, SS13 3ER; Wayne Birch, Church Street, LN7 9NP; G K Lewis, Oakhill Road, KT21 2JG; R J Spencer, Hope Road, Essex; Richard Davy, Tufton Street, BD20 0PN; Alistair Gentry, Undercliff Road West, IP11 8AN; Hallam Bannister, Robin Way, BR5 3AQ; Daniel Ingley, Mellowdew Road, DY8 5NQ; R Harris, Copley Lane, CR2 3EE; Leo Mephan, The Lowland, MR1 1AS; Stephen Prior, Jephburgh Avenue, G73 3EW; Michael Wright, Selmans Hill, W53 3RJ; Mr William Killeen, Morcom Road, B11 2JE; Anthony Davies, Princes Avenue, CM3 6GA; Duncan Peake, Moss Lane, WA15 6JG; Alan Jones, Sandrock Road, U12 8LT; David Sullivan, Jesson Road, WS1 3AX; Spencer Wakeaim, Mill Hill Road, L61 4XF; Mark Sibson, Teal Court, WF5 0PF; Edward Sykes, Kingsgate Street, SO23 9PF; Khalid Jamil, Gladstone Park Gardens, NW2 6LA; Miguel Soares, Rua Inacio De Sousa, Portugal; James Hodgson, Askrigg, DL8 3HZ; David Bone, Melrose Avenue, NE31 2JF; Wayne Athey, Carr View Road, S61 2BJ; David Waters, Penglais Road, SY23 2EU; David Twigg, Palmerston Road, PR9 7AQ; Richard Moss, Kenn Street, BS21 6TN; John Banks, Malton Avenue, WA3 2PH; David Payne, Crafts End, OX11 0SA; David Hamilton, Kirkton Avenue, G13 3EJ; Michael James Brown, Towngate, WF5 0QD; Paul Robertson, Annan Avenue, G75 8XT.

THE ULTIMATE LEISURE LOCATION

The competition held to mark the imminent launch of *CRU*'s futuristic game, *Room Ten*, had you all leaping around trying to design a leisure complex for the year 2050. We had a very healthy number of entries but as judge, referee and umpire, Hannah Smiff decided that the entry that deserved top prize of a squash outfit, a couple

of squash lessons plus a copy of *Room 10* was the one sent in by **David McCann** of Hordle Promenade North, SE15 6EG.

On-screen workouts rather than on-court workouts should be easy for the following people, who all collect a freebie copy of *Room Ten* by way of consolation.

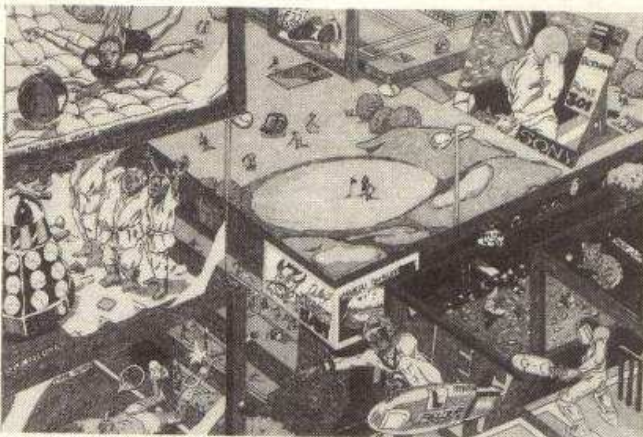

RUNNERS UP

Nigel J Palmer, Glenalmond, NR4 6AG; Alan Walton, Peel Close, BB2 3NG; Mark Watkins, Stanley Hill Avenue, HPT 9BB; Matthew Round, Craig-Y-Don Road, LL57 2BG; Bruce McCoubrie, Kingsway Park, BT5 7EW; Spencer Gore, Shooters Hill, RG8 7DU; Mathew Ayres, North Street, CM0 7DF; Daniel Marshall, Mayfield Road, FY8 2DS; Tom Price, Claredale Road, EX8 2EE; David Griffin, Fairfield Road, Worcs; Howard Carlisle, Alexandras Road, LS18 4HD; David Jackson, Landsmoor Drive, PR4 5PE; Paul Chan, Conway Road, LL29 7LR; Paul Wakelin, Castell Drive, LE8 0DE; Shaun Hill, Finlay Close, ME13 7SH; Paul Andrew, Brentwood Avenue, M30 5JS; Taylor, Dodd, Waybridge, TF7 5QA; Kevin Curtin, Elm Grove, IV12 4SN; Barry Lawes, Parker Road, TN34 3TH; Darren Barton, Partridge Way, South Wales; Brian Reid, Tixall Road, Birmingham; Colin Duff, Caledonian Road, N1 1EG; Michael Whitlock, Corcon Crescent, NN6 0PW; Stephen Grant, Osborne Road, BN1 6LR; Justin Doel, Walsingham

Road, Nottingham; Jefferson Sheard, Crownest Road, BD16 4HQ; A Taylor, Bramshaw Rise, KT3 5JU; Graham Leech, Moor Park Avenue, CA2 7LZ; Ian King, Foyard Road, DY4 8BH; David Gorton, Revidge Road, BB1 8DJ; Rob Harris, Foxley Lane, CR2 3EE; Brett Patterson, Hague Row, S2 55B; David Patterson, Windmill Field, PO7 6PL; Darren Purcell, Rosemary Lane, PE16 6EP; Gary Wedge, Newhall Street, WS11 1AD; Andrew Dobson, Crossbush Road, PO22 7LT; Andrew W Mitchell, Bruce Drive, DD7 7DE; James Guise, Charles Avenue, LN11 0BG; Stuart Wardale, Field Lane, L10 0AG; Paul Wheatley, Glebe Road, LE6 0GT; Alfio Indelicato, Hill Street, BS3 4TS; Jonathon Webster, Vienne Close, NN5 6HE; Simon Tipper, Holgate Park, L23 1TL; Jason Davis, Cherry Walk, PE21 8AS; Piers Bolton, Avondale Avenue, KT10 0DA; Jason Gough, Prince Charles Avenue, ME12 3PN; Quinton Silveira, Hatcham Park Road, SE14 5QE; Robert Gabriel, Highland Terrace, EX15 3EN; Sean Cooney, Galway Road, Ireland; Richard Dodd, Stable Lane, WV10 7DN

DESIGNER DRUIDS

For designing the ultimate in add-ons luxuries for a hard-working Druid, FIREBIRD offered a unique copy of *Druid*, the game, to the winner of this comp. And that lucky winner, is no less than **Jarred Smith** of Wilton Bank, TS12 1PD.

Twenty runners up each receive a Firebird T Shirt:

Adam Wilde, Shetland Way, LE8 3PU; Christian David Stone, Trendlewood Park, BS16 1TE; Kyriacos Tomboulougov, Girdlestons Walk, London 5DP; David Payne, Crafts End, OX11 0SA; David Webb, Jermyn Road, PE30 4AD; Ken Davidson, Ballysillan Road, BT14 6RA; Sean Cooney, Galway Road, Ireland; Alan Walton, Peel Close, BB2 3NG; Anthony Witson, Crosswood Close, HU7 5BU; Guy Keough, Newington Avenue, BB1 9RG; James Harris, Saltburn-By-Sea, TS12 1BP; Nicholas McMahon, Woolfords Lane, GU8 6LL; Kevin Curtin, Elm Grove, IV12 4SN; Collin Nightingale, Gipsy Road, Kent; Peter Khan, Oldacre Road, BS14 0HN; Paul Dilks, Larch Crescent, NG8 4DL; Lee Clarkson, Peel Place, DL14 7RR; Leo Dericl, Sunnyside Park, Cornwall; Adrian Goodwin, Prince of Wales Drive, SY21 7UE; Philip Hunt, Princess Street, NP3 1AS



UNITED STATES DEPARTMENT OF JUSTICE
FEDERAL BUREAU OF INVESTIGATION
Washington, D.C. 20535



GOVT. OFFICER
Mitsumasa
London



Name: Mitsumasa Mitsumasa
Nationality: Japanese
Date and place of birth: 1940 Okinawa
Height: 5' 11"
Weight: 165 lbs
Background: Combat instructor in Japanese Army
Im Dan black belt. Small arms and knives expert. Highly conversant with micro-circuitry.





COLOURING COMP

It was SCOOOOBY DOOOOBY DOOOO time when ELITE asked you to help pull Scooby together before breaking out the colouring pens and putting a little colour back in his cheeks. The prizes awarded for this selfless act were a copy of *Scooby Doo* the game — a tasty Scooby snack for any hungry Spectrum's RAM.

PRIZEWINNERS

Khalid, Gladstone Park Gardens, NW2 6LA; Paul Laney, Rennets Wood Road, SE9 2ND; Jonathon Woodhouse, Horsecroft, SN7 8LL; Gordon Goode, Halffields, CV21 1TS; Robert Turner, Cliffe Lane, BB6 7PG; Glenn McDowall, Ashfield House, SP2 7EG; Vanessa Sheehan, Osprey Court, Manchester; Daniel Hall, Yardley, Birmingham, B26 1AT; Simon Colquhoun, Ashford Avenue, UB4 0L2; Jorge Esperanca Rosa, Marinha Grande, Portugal; Luke Sherwin White, Parkhill Road, NW3 2YP; Sue Hammore, Queens Road, PO36 8DT; Piers Berry, Stainsby Drive, NG18 3EX; Jason Albon, Giltrap Road, IP31 1TD; David Jeffrey, Lawrence Street, G11 5HQ; Martin Hammarberg, Wise Lane, NW7 2RD; Simon

Davis, Old Quarry Avenue, S31 8RW; Nigel J Palmer, Glenalmond, NR4 6AG; Richard Anderson, Kincora Avenue, BT4 3DW; R Gaherty, Kippare Avenue, BA5 2TT; Chris Fowler, Hazel Walk, NP44 2NW; Oliver Leeds, Tudely Lane, TN9 2ER; Stephen Brown, Leicester Road, BB1 3JX; Simon Baines, St Wilfred's Court, RH16 3QQ; H Rai, Empress Road, DA12 2QR; Chris Greenan, Chiltern Road, HP22 4QQ; Kelvin and Natasha Dove, Lincoln Road, BH12 2HT; David Johnson, Valley Road, S8 9FY; Alan Parsons, High Street, BS11 0DE; Craig Gibson, Mildmay Road, Essex; Lee Gridley, King Gorge Vi Avenue, Essex; Ian Doggett, Bucklesham Road, IP10 0PD; Robert Draper, Randall Road, NN2 7DG; Jamie Kidd, Braehed Drive, Scotland; Jonathon Ridehalgh, The Hawthorns, LE6 0SS; Theo Koerner, Reiton Place, NE25 8DU; David Harrison, Stokesay Close, B69 1XG; Jane Arthurs, Park Road, N8 6JY; John Graham, Chestnut Avenue, Nr Hull; Graham Persson, Balfour Street, EH6 5ER; Freddie Bond, The Hollies, BT38 8HA; Kasper Kragelund, Høeeghuldbergsgade, Denmark; Stuart King, Chatelherault Crescent, ML3 7PR; Simon Holland, Rotherthorpe Road, NN4 9HY; Zaid Mohammed, Gloucester Road, KT1 3RG; Paul Gibney, The Hollies, BT38 8HA; Jason Hall, Carllops Crescent, EH26 0DW; Neil Edwards, South Field Road, NG8 3PN; Silvio Minnemann, Porto, Portugal; Alan Jepson, Rossall School, FY7 8JW



GOING TO WAR

T SHIRTS AND GAME

Simon Holland, Rotherthorpe Road, NN4 9HY; Gavin Philip Latz, Andover Road, GL50 2TS; Michael Sanders, St Patricks Road, ML11 9EH; David Doughty, Greenwood Close, NR16 1HB; Iain D Forbes, Rydall Road, LA1 3HA

Oh Dear! It just goes to show you can't trust the Spiky Haired Ones over on ZZAP! — when I asked them if I could borrow back the wordsquare I did for them in their magazine a little while ago, they said yes and, sniggering, handed it over. Foolishly, I didn't check it and found they had sabotaged the comp a tiny bit. "LAUGH" wasn't in the wordsquare, as lots of you wrote in to say.

Anyway, everyone had the same problem, so here's five winners out of the Girlie handbag who collect a copy of MARTECH's WAR together with a MARTECH T Shirt. Forty-five runners up should receive a copy of War as soon as it's ready . . .

COPIES OF WAR GO TO

Andrew Brewer, Spencer Street, West Yorkshire; Lee Foster, Wantz Chase, CM9 7DN;

Luke Webb, West Dyke Road, TS104JS; Peter Homecker, Grofthojparken, Denmark; Paul Holden, Crescent Road, BL3 2JR; Roy Johnson, Park Avenue, S64 9PG; Richard Shaw, Riverside, TA5 2QX; Mathew Hassall, Marian Drive, CH3 5RX; Graham Easton, Granson Way, LN4 1EY; Mr D Dale, Whistler Close, RG21 3HN; Craig Northam, Walsall Road, B42 1EH; Julian C Rex, Southfield Road, BS9 3BG; Jamie Mills, Valley Road, SA69 9BP; C Robb, Levensgarth, LA12 8AG; Brian Kirby, Lower Kensington, Ireland; Richard Dodd, Calf Heath, WV10 7DN; Daniel Smith, Prescott Walk, M34 1RH; Andrew Males, Lammas Path, SG2 9RN; Antony Desert, Garston Crescent, WD2 6LD; R Deaper, Warwick Road, CA1 1LH; N Oulieu, Denham Road, SS8 9HB; R Douglass, Ajax Close, WS6 6JU; Jonathon Beech, Duffryn Close, NP1 9PD; Stuart Macfarlane, Keir Street, FK9 4AY; Jonathon Ridehalgh, The Hawthorns, LE6 0SS; David Gorton, Revidge Road, BB1 8DJ; G Muscott, Rammoor Court, S10 3DW; S Summerscales, Woodside Crescent, WF17 7DY; Wing Hong Cheung, Carter Lane, NG18 3DH; Barrie Day, Eastwood Road, SS6 7LH; Brian Conner, Main Road, CO12 5JE; David G Knock, Grange Road, B66 4NG; Greig Christie, Tower Tern, KY1 3BA; Paul Weeks, Trafalgar Avenue, DN34 5RE; David Rosie, Nicolson Street, KW1 5HH; Marc Canale, Elm Road, DA8 2NN; Craig Haworth, St Margarets Way, BB1 1PD; Steven Tifford, Childwall Valley Road, L16 4PD; Nicholas Gibson, Allington Drive, TS23 3UE; Scott Marjoribanks, St Giles Square, FK1 4JH; Clive Barnard, Rosemary Avenue, CT10 2ES; Michael Dutton, Charnwood Road, LE9 8FU; Simon Alder, Crossfield, PR4 5EH; Steve Whitton, Lansbury Road, NG21 9QH; Patrick Gould, Stanley Park Drive, HA0 1SQ

ADVENTURE CHART WRITE-IN COUPON

Please use block capitals and write clearly!

Name

Address

postcode T SHIRT SIZE

Send your coupon to: CRASH ADVENTURE TRAIL, PO BOX 10, LUDLOW, SHROPSHIRE SY8 1DB

My top five programs are:

TITLE	VOTE OUT OF TEN
1	_____
2	_____
3	_____
4	_____
5	_____

CRASH HOTLINE WRITE IN COUPON

Please use block capitals and write clearly!

Name

Address

Postcode

T SHIRT SIZE

Send your coupon to: CRASH HOTLINE, PO BOX 10, LUDLOW, SHROPSHIRE SY8 1DB

My top five favourite programs in descending order are:

TITLE	PRODUCER
1	_____
2	_____
3	_____
4	_____
5	_____

FIST II

Smash your way through an immense, hostile world where Ninjas and Shoguns lie in ambush and wild animals crouch ready to strike! Take the challenge - only you a true FIST master can survive to the top!

Amstrad £9.95

C64 Cassette £9.95, Disk £14.95.

Spectrum £8.95

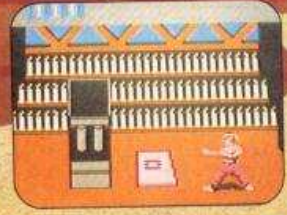
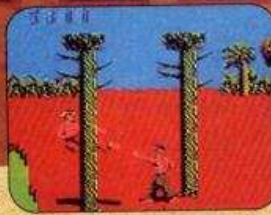

Actual screen shots from C64 version. Other versions may differ.

from

MELBOURNE HOUSE
The Home of the Hits!



AMSTRAD £8.95

ZX SPECTRUM £7.95

COMMODORE 64 £8.95

Yie Ar KUNG FU II



Imagine

...the name
of the game

The officially endorsed game by
Konami®

Sequel to the hugely successful Kung Fu simulation.

Eight more deadly opponents to combat as you develop your karate skills and advance to become a black-belt master.

Authentic fighting moves with 4 different locations create an outstanding and realistic atmosphere.

Imagine Software (1984) Limited • 6 Central Street • Manchester • M2 5NS • Tel: 061 834 3939

AMSTRAD £8.95
ZX SPECTRUM £7.95

Konami's
GOLF™

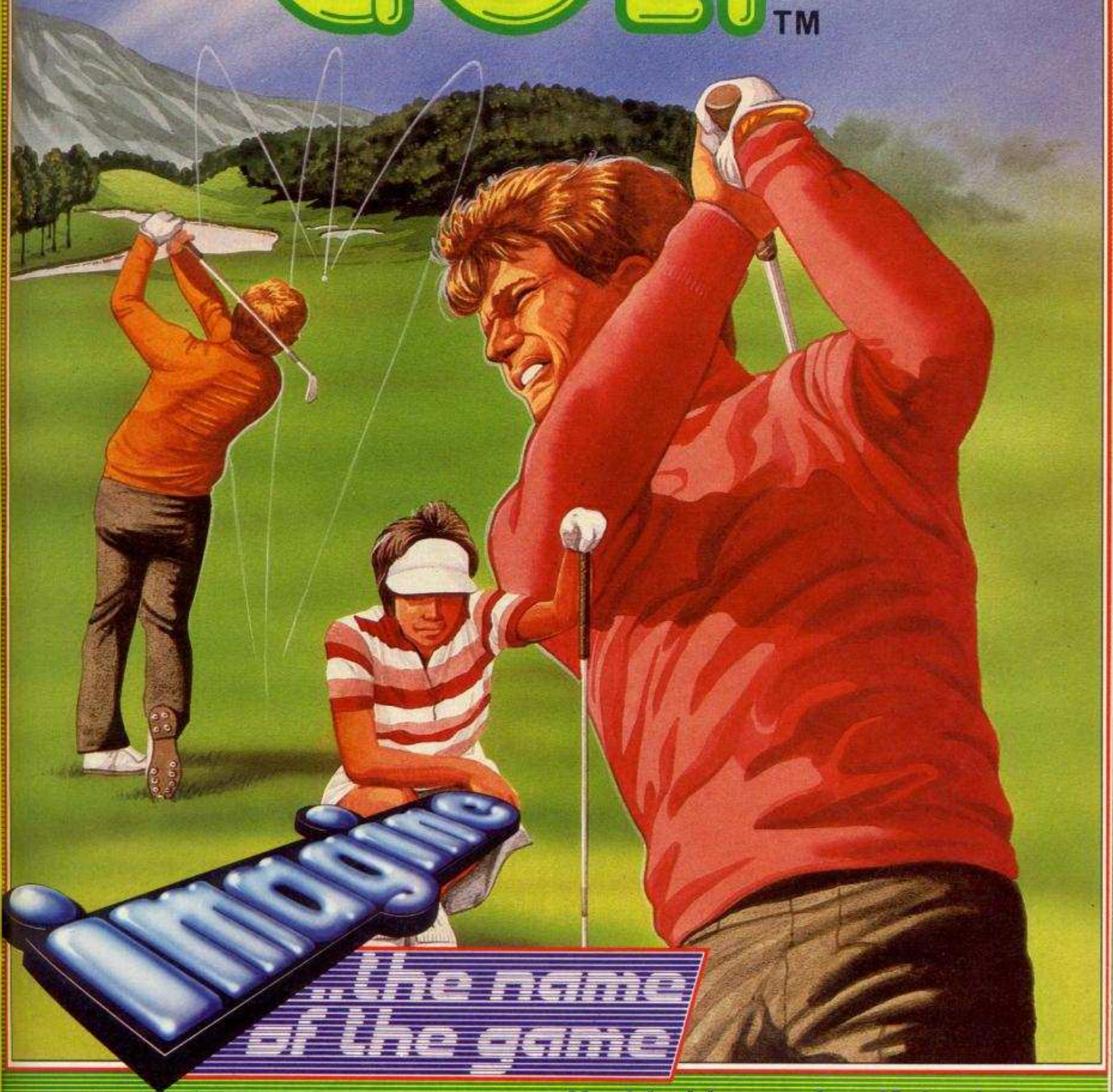

*...the name
of the game*

Select your club and prepare to tee-off with this superb golf-simulation from Konami reproducing all the features from the live game – choose stroke or match play with differing terrain and conditions. So if the weather turns bad don't worry it'll just improve your play for the sunny days!

DARK SCEPTRE

Mike Singleton

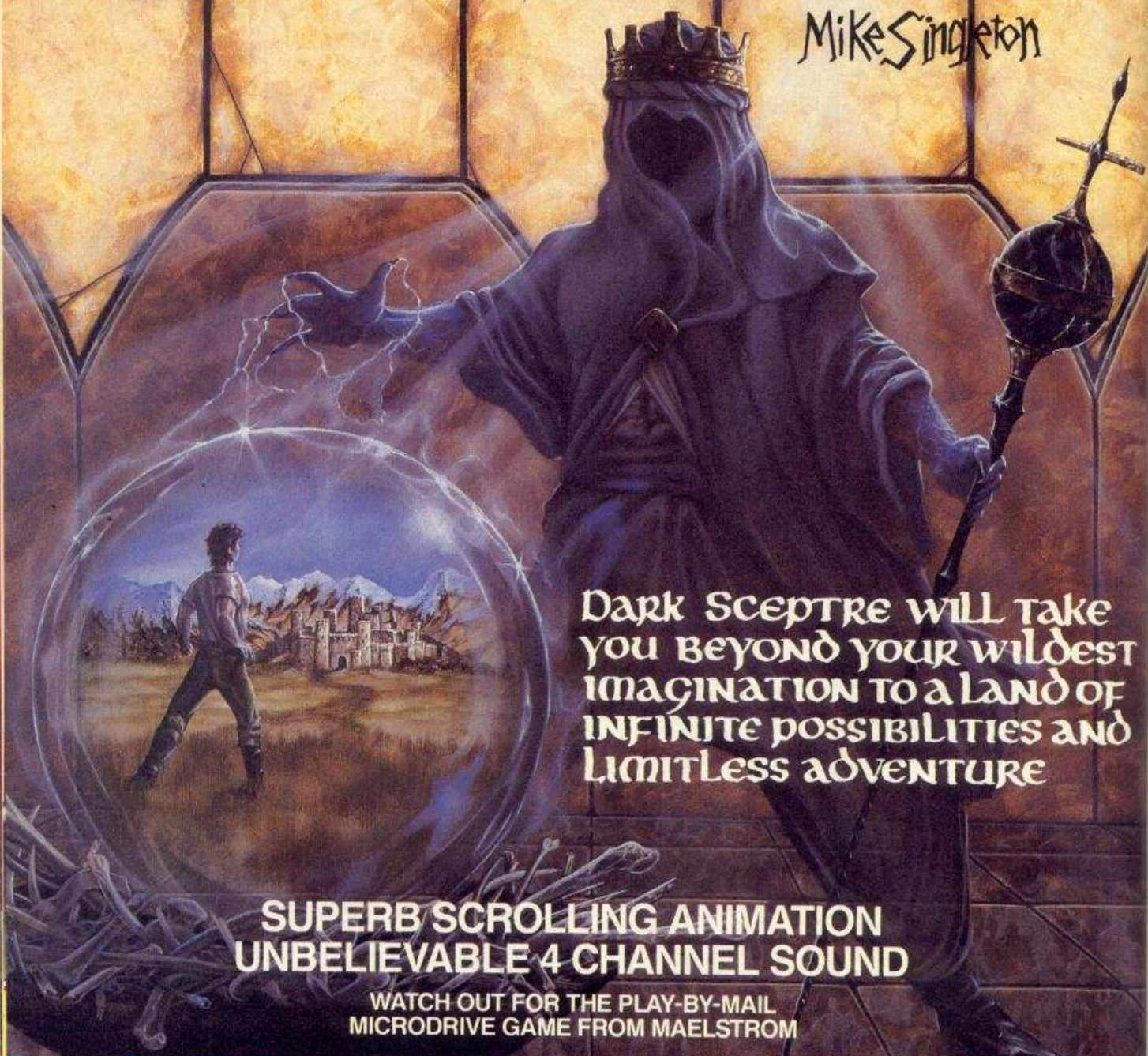

Dark Sceptre will take you BEYOND your wildest imagination to a LAND OF INFINITE possibilities and LIMITLESS adventure

**SUPERB SCROLLING ANIMATION
UNBELIEVABLE 4 CHANNEL SOUND**

WATCH OUT FOR THE PLAY-BY-MAIL
MICRODRIVE GAME FROM MAELSTROM

BEYOND

DARK SCEPTRE IS AVAILABLE NOW FROM ALL GOOD SOFTWARE DEALERS. IN CASE OF DIFFICULTY PLEASE WRITE TO BEYOND SOFTWARE FIRST FLOOR 64-76 NEW OXFORD ST. LONDON WC1A 1EU

**SPECTRUM 48K
£9-95**

TECH NICHÉ

VI HAR SVENSK MIDI



No, you didn't read it wrong - it's just a smattering of everyday Swedish by way of an introduction to the latest MIDI interface from the land of snow.

"10" SYSTEMS MIDI SEQUENCER

Producer: Icon Designs
Price: £199.95

Someone in Sweden has gone to an awful lot of trouble to think this one out. The result is a very versatile and not too hard to use real-

stand several bouts of tap-dancing. A ribbon cable attaches it to the back of the Spectrum and, oops, we hit a slight obstacle. It's been designed to fit the rubber-key variety and so one either rips the keyboard off the Plus or goes



The MIDISYNC hardware in all its glory. It only fits comfortably onto the rubber-keyed Spectrum, so be prepared to buy an extension if you have a 'proper' keyboard. . . .

time sequencer with rather advanced editing facilities. It goes two tracks better than most low-budget sequencers in that it will record up to ten tracks that can be played back simultaneously. Now, there are several MIDI sequencers about of both the real and step time variety but this one scores on two fronts: in the way in which it records the information and in the degree to which you can fiddle about with (sorry, edit) it afterwards.

The hardware is contained in a sturdy brushed steel box coloured red which looks like it would with-

stand several bouts of tap-dancing. A ribbon cable attaches it to the back of the Spectrum and, oops, we hit a slight obstacle. It's been designed to fit the rubber-key variety and so one either rips the keyboard off the Plus or goes

in search of a suitable plug to replace the one supplied. It has two MIDI outs, a Roland compatible DIN sync (for older synths made by Roland), Clock In/Out with a selectable amount of pulses per crotchet which enables you to harness the forces of most older sequencers and non-MIDI drum machines. It can also give out signals for tape synchronization which means that a spare tack on a multi-track recorder can be used to synchronize the whole piece as you record it onto tape with overdubs — offering endless over-dub possibilities.

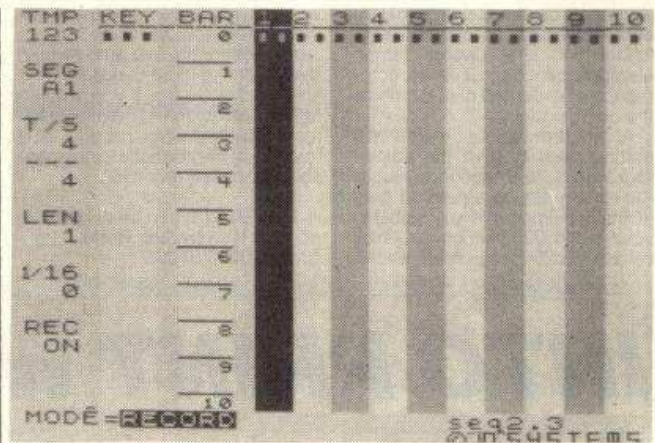

The basic screen display generated while you fiddle record a sequence

The software arrives on cassette but can be downloaded to Microdrive. It has only one screen display that shows ten columns, one for each track, which are in alternating yellow and white for visibility even in monochrome. When a track is being used it turns a jolly shade of black. The bar numbers are listed from top to bottom of the screen in one of the left-hand columns and each track can accommodate up to 1,000 bars. A 'memory-used' column to the left of the bar number column gradually fills up as memory space is used.

The recording process works not a little like the cut-and-paste facility of a word processor. Sections of your piece of between one bar and 255 bars in length are recorded in one go — each section is termed a 'segment' — and given a reference: A1 B2 C1 and so on. When recording a segment, the desired speed has to be selected — this could be a bit tricky on the first segment if you don't have a drum machine, as there appears to be no audible metronome click.

A segment cannot be played back unless it has been inserted into a track: look at the screen display and work out where you want a segment to be inserted and whiz the track pointer to the required position. For some reason or other the track position line works from Z and W keys rather than the arrow keys which seemed a little odd. It is a horizontal dotted line that bisects all track columns and therefore gives you the bar number you are at. So far so good. The beginning and end of each segment is shown by a solid

horizontal line across the track column.

When a new segment is being recorded you start from wherever you have positioned the track pointer and can choose which segments to hear that are coincident with the track pointer position. It has a convenient 'Go To Bar' function to save tedious screen scrolling. Cunningly, when a segment in the middle of the piece is being recorded and a MIDI drum machine or other sequencer is in use, the system locates the correct bar in the drum machine so that everything plays back from the correct bar. This is part of MIDI protocol known as 'song position locate' and is only usually available when you pay above £500 for a disk-based sequencer!

Once a segment has been recorded it is possible to do virtually anything with it that MIDI allows: for instance correcting your bum timing (more correctly called 'quantising') to a hemi-demi-semi-quaver (known as 96th note quantisation) and some of the MIDI codes can be added or removed for various functions such as program change, after touch, pitch-bend, modulation wheel and sustain commands.

It is useful to be able to disable the velocity sensing function until it's absolutely necessary as this takes up piles of memory very quickly indeed and has often been the stumbling block of other real-time recorders. If you are sufficiently patient you can refer to a MIDI codelist and insert individual instructions. Any segment can be transposed, and in fact a

completely different set of MIDI codes can be inserted. Two segments can be merged together — very useful if you want to play something on one keyboard but are incapable of realising it in one go (there's a lot of it about at Christmas). The time signature (beats per bar) of each segment can be different although once specified it is permanent. This is really more by way of an aid to find your way around the tune than anything else.

Having roughly assembled the segments in the tracks, each track is assigned to a MIDI channel. Segments can be copied and generally inserted or deleted anywhere you like. Overall tempo changes can be put in as commands or executed in real time as the piece is playing.

At first, the concept took a little getting used to. But the advantages are quite staggering. Usually the screen display shows 11 bars at any one time but it is possible to squash all 1,000 bars on screen by selecting different screen resolu-

tions from 1 to 8. Things get pretty tiny, admittedly, but you have a very useful overview of the whole piece, warts and all.

Generally this is a friendly and flexible sequencer that offers facilities found on far more expensive dedicated sequencers but with the advantage of visual display. The User Manual, although very comprehensive, suffers a little as it does not include a step-by-step example with illustrations — an approach that is a lot quicker and easier to follow.

The sequencer isn't cheap: £200 may seem like a lot of money to lash out, but I hear there are more programs en route via the North Sea for the unit, and I would think that like most things the end justifies the means. If you are into MIDI music systems then this represents a first class product at a fraction of the cost of a less amenable dis-based recorder.

Icon Design can be contacted at 423 Newmarket Road, Cambridge, 0223 61293

TUNEFUL FELLOWS

Meanwhile, Jonathan Habrovitsky sent me a tape of commendable tunes realised on the *Music Box* from MELBOURNE HOUSE. In fact he combined this with a selection of tunes from games on the other side to make a sort of 'Best of Spectrum' album. I think I preferred his own performances which just goes to show what one man and his Spectrum can do when they try. My apologies to Jonathan for the delay in returning his tape. The turmoil of CRASH Towers, the chaos of Chateau Bates and several rush previews all add up to delays, delays.

From the same end of the world, to wit, Glasgow, Rodney Berman has sent in his own *Music Machine* program - not to be confused with

the RAM/FLARE product reviewed last month. Rodney's program runs on the 128, the FULLER Master Unit or the DK'TRONICS Sound Synth. The Competition Minion was last seen crawling around various corners of the office trying to locate our DK'TRONICS synth, but anyway I gave it a blast on the 128 and good fun it was too.

The program uses all three channels of sound and has some very classy graphics for both the notation and screen load. It comes complete with a suite of very well worked out demo tunes and is not too hard to get to grips with. From what we can gather Rodney is updating his program on a regular basis and for the sum of £2.50 for cassette or £4 for Microdrive you too can ruin everyone's Christmas by overriding the Queen's speech with his program. Rodney lives at 5 Orchard Drive, Giffnock, Glasgow, G46 7NU.

INTO PRINT WITH RAM

Ace wordprocessor evaluator, Dominic Handy, gets to grips with a neat package from the people who brought you the Music System ... This time it's words they're manipulating, rather than noise

RAM Print with RAM

Write

Producer: RAM Electronics
Price: £34.95

This latest offering from hardware specialists RAM consists of a little black box into which has been crammed a Kempston joystick interface, centronics printer interface and cable, and a built in word processor on a ROM chip.

RAM Print is compatible with all Spectrums, but requires initialising in the 128K mode, and unfortunately, RAM Write can not be used on 16K machines. The Kempston interface is compatible with all Atari type 9 pin joysticks, and is now recognised as the industry standard joystick interface.

The printer interface emulates the ZX printer and is generally compatible with all software or hardware producing printer output. The printer interface can be altered to suit your application and printer, by accessing a menu held in ROM, via the simple command, LPRINT "(c)set" and changing the values hiding there.

Line feeds can be turned on or off after a carriage return, according to your printer's need. It is also possible to tell the interface whether you want the printer's ASCII values printed or the Spectrum's — this is how you can get

Spectrum keywords printed, or the printer's own special characters.

Text can be copied from the screen, or the screen itself copied, pixel by pixel, to the printer. Screens are copied very quickly in a choice of two sizes, although with the large copy you loose the right hand two columns — which is very strange and annoying — and the picture seems stretched across the printer. Lastly on the SET menu you can define the width of the printer you are using, from 0-199 characters. All the options are preset to sensible values, and as such this menu does not usually need altering.

Of course to use your printer interface to its full you really need a word processor, and to make things easy for you RAM ELECTRONICS have teamed together with HARD SOFTWARE to include a word processor, also in ROM. This is entered by the command LPRINT "(c)word".

When accessed, the program presents you with a simple status bar, command window and a large text window. Unfortunately, RAM Write doesn't score very well on the WYSIWYG (What You See Is What You Get) stakes as the text editing window is only 32 characters wide, and the program doesn't word-wrap or justify your text as you type it.

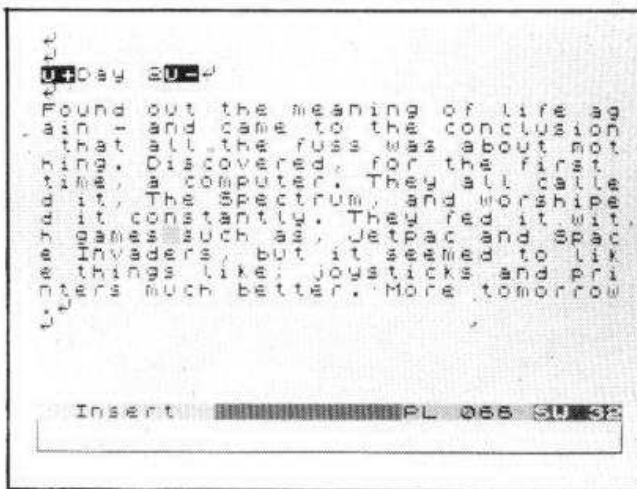

In insert mode on a text file. Note the underline control codes that surround "Day 2" at the top of the screen

If you want to see what the output will be like you have to choose the DISPLAY command: from this you are sent into a display window covering the whole of the screen, with a 32 or 64 characters width — you can only preview the text in this mode by travelling around via the cursor keys. Editing the existing text is not allowed. In this mode the formatted text is displayed, always word-wrap and only right justified if defined as such. Also if you chose to underline some text then it shows as such on the screen, as well as on the printer — very useful if you are one of those people who forgets to turn off the underline token, and gets the whole of the text underlined.

Before starting a 'cold' piece of text it must be given a name. This

is then stored by the program and given as a default when loading, saving, merging and verifying other pieces of text to and from Microdrive or tape, which speeds up the process tremendously. Of course if you load text in, then its name is taken as the default.

All commands are entered as single letters: entering 'E' puts the user into EDIT mode, and 'L' into load mode, for instance. Text is entered directly and symbols that are normally obtained via EXTENDED MODE are entered by using SYMBOL SHIFT — EXTENDED MODE is reserved for entering printer format codes, which are entered by typing a single letter code followed by a +, — or a number for some commands. For example to start con-

H[NICHE]TECH[NICHE]TECH[NICHE]

densed underlined text with a page number 3 you would type: c+u+p3 in EXTENDED mode. It appears on the screen in inverse video when in EDIT mode, but disappears in DISPLAY mode. This means that all printer information is always displayed and it saves the time of going through lots of menus to do one task as the expense of screen neatness.

The program contains condensed, double strike, double width, form feed, centering and underline EPSON-compatible printer codes — and if your codes aren't on a preset command they can be entered by typing 'k' followed by the desired codes. Perhaps more codes should have been preset — I didn't fancy the idea of looking up the double height or emphasised print codes every time I wanted them.

There is no way parts of text can be printed or the same text printed many times in one go — these omissions separate the home processors from the more professional word processors. There's no doubt in my mind that *RAM Write* is definitely for the first-time home user.

There are two ways of entering text: either OVERWRITE the existing text or INSERT into the existing text. The cursor can only be moved around the text character by character or page by page. This seems like another major flaw, as once a large chunk of text has been typed in it takes a long time to find a specific place.

Marking blocks of text is no problem — just enter 'm' for MOVE, 'c' for COPY or 'k' for KILL TEXT in the command mode. Then

THE Trendy Black Interface box that stylises RAM ELECTRONICS PRODUCTS. This one contains their

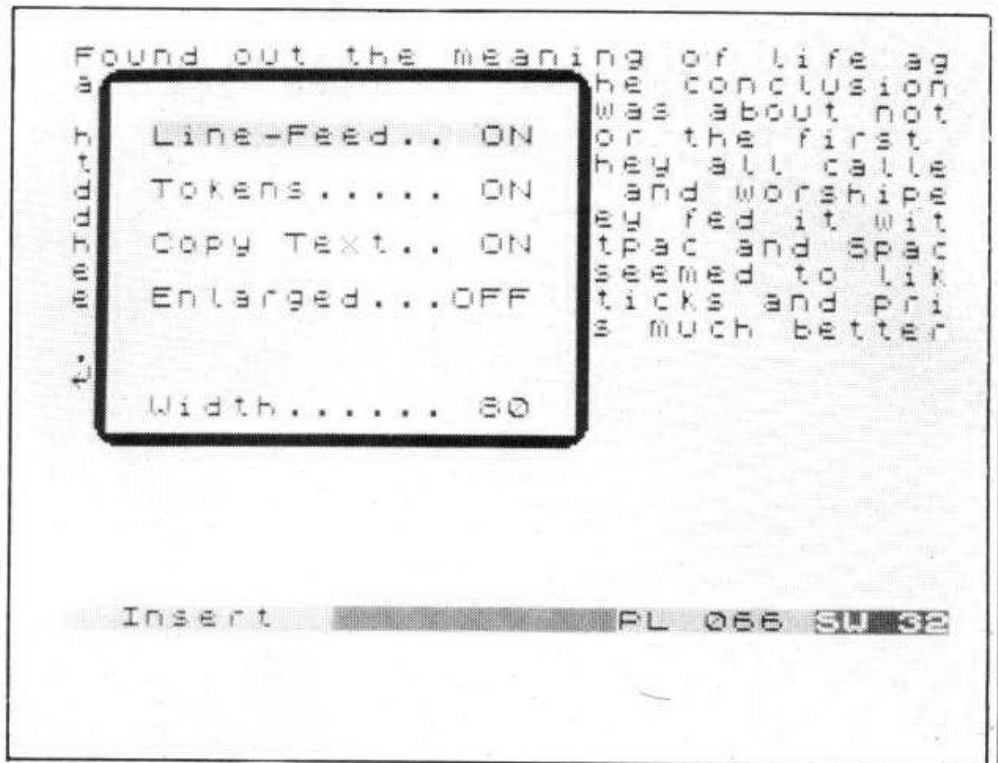
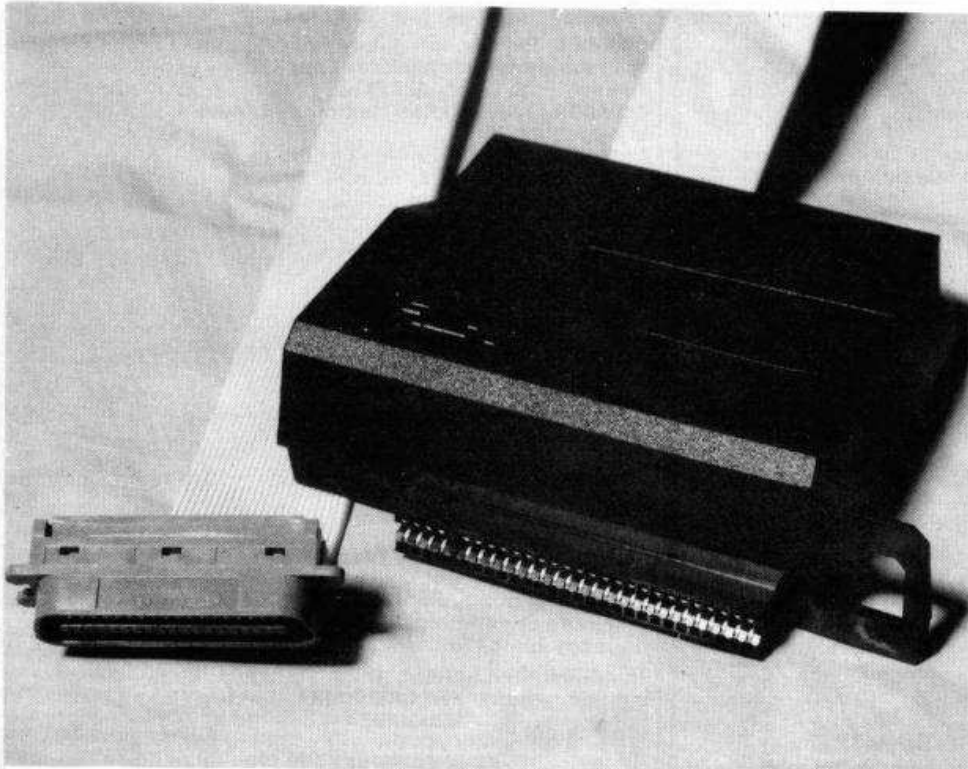

The printer control menu windows out of a textfile during a wordprocessing session

enter the text, mark the beginning and end of the block where you want it in the file by pressing ENTER when the cursor is at the right places in the text, then that's

it—the block moves at the speed of light.

FINDing a string is also initiated from the command mode. All occurrences of a specified string can be replaced, or the program can step through each find and

replace individually.

Individual pages can be defined in length and width, with margins on the left and right and with blank lines at the top and bottom of each page to separate it, and the page number centred at the top.

Even though *RAM Write* doesn't contain many extra features as such, it has all that is needed for a quick and decent output. It compliments *RAM Print* well as it is simple, quick and efficient to use. The printer interface must be one of the best on the market as this too is simple but extremely effective. Value for money is superb. You would usually find yourself paying at least £35.00 for a decent ROM based printer interface. But what *RAM* give you, if you were to buy the equivalent facilities separately, is £8.00 worth of joystick interface, a £10.00 word processor and a £35.00 parallel interface, all for £34.95. I have no doubt that *RAM Print* represents the top printer interface package at the moment. It's the perfect purchase for the beginner.

NEXT MONTH

For more tips on how to be musically self indulgent over Chrissy time you'll have to buy our Christmas Special packed with pages of musical info and recommendations. See ya next year. Me? I'm off for a week in Canada; I'll let you know what's happening over there.

Jon Bates

NOW AVAILABLE – the official Spectrum Upgrade!

Turn your Spectrum into a Spectrum + for just £23

Makes a great Christmas present

ORDER NOW!



- Professional full-size keyboard – includes 17 extra keys.
- Responsive typewriter-style action.
- Accepts all current Spectrum software and peripherals.

+ £1.50 p + p

ACCESS WELCOME

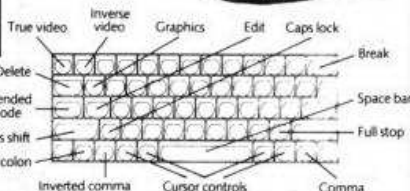

The official Spectrum Upgrade. Naturally your upgraded computer will accept all the peripherals in your Sinclair system-Interface 1, Microdrives and so on – as well as all Spectrum software. Just as important, new Spectrum software and peripherals will be designed with the Spectrum + in mind. So the Sinclair upgrade adds **stylish looks, new capabilities** ... and new potential for the future.

Here's some exciting news for Spectrum owners ... the official Spectrum Upgrade Kit. The Upgrade has everything you need to turn your Spectrum into the stylish new Spectrum +. You don't even need an understanding of electronics, just the ability to solder a few wires together! The leaflet in the kit gives clear, step by step instructions. If you're not sure about doing it yourself, don't worry. Simply return your 48K Spectrum to us and for **£29.95** + £1.50 p + p we'll upgrade it for you.

The bigger, better Spectrum keyboard

The Spectrum + measures 12½" x 6". It has a large typewriter-style keyboard, with hard, moulded keys. You'll find the new keyboard has a smooth, positive action – ideal for touch-typing, word processing, simulation programs, and extended programming sessions. Two retractable legs give a **perfect typing position**. There are 58 keys in all, including 17 new keys. Programmers will be pleased to see dedicated punctuation keys, a space bar, and separate shift keys for graphics and extended modes. And a reset button allows you to clear a program from your computer's memory without disconnecting the power supply.

HOW TO ORDER BY MAIL

1. If you require us to do the upgrade for you please send **£29.95** + £1.50 p + p. Total **£31.45**.
 2. Should you require the do-it-yourself kit just send **£23.00** + £1.50 p + p. Total **£24.50**.
 3. If you require your Spectrum to be repaired and upgraded to a Spectrum Plus we have a special offer price of just **£50.00** complete.
- Orders can be placed by using your Access Card on the numbers below.

VideoVault Ltd.

Upgrade Dept. 140 High Street West, Glossop, Derbyshire SK13 8HJ
Tel: (04574) 66555/67761 & Manchester 061-236 0376

© Copyright Videovault Ltd No 689032

48k SPECTRUM

Fed up with ordinary fruit machine games?

★ NOW ★

A fruit machine simulation with the most up-to-date features, sound and graphics

FRUIT 2010

☆ For fruit machine experts to fun players

☆ The most advanced and realistic fruit machine simulation

FEATURES: Real reels – Gold Rush – Roulette-style-gamble – £100 jackpot – Holds – easy keys – Nudges – HIGH-speed Spinning Reels – Save Down – Large Graphics – Mystery Box – USES ALL 48K – 12 different fruits – super sound – Cash Run – MULTIPLE ODDS – multi-colour – MAX. NUDGES –

Number board
PLUS LOTS MORE

Please send **£6.95**
which includes P & P

Cheques or P.O. to—
ROSSWARE (CR),
646 London Road,
Westcliff, Essex SS0 9HW

FOR FAST DELIVERY
Software from **ROSSWARE**

COMCON

COMCON The best-selling, fully programmable joystick interface for the Spectrum 48K, Plus, 128 and 128 Plus 2 **£17.95**

COMCON TWIN includes second parallel joystick port **£20.95**

DIGIT keyboard improvement kit for the Spectrum Plus and 128; replaces the dreaded rubber membrane **£9.50**

QUICKSHOT 2+2 the popular joystick modified to provide two independent fire actions **£11.95**

FLIGHTLINK HOTSHOT excellent microswitch action & two independent fire buttons **£8.95**

PLUS TWO converter to connect any Atari compatible joystick to the Spectrum Plus 2 **£2.50**

EXTENSION CABLE 6" long for any Spectrum add-ons **£7.60**

Prices include VAT & Postage

Name: _____

Address: _____

Postcode: _____

I enclose a cheque/postal order for £ made payable to **FREL LTD.**

TEL: (0584) 4894 **FREL LTD.**
1 HOCKEYS MILL
TEMESIDE
LUDLOW
SHROPSHIRE SY8 1PD



TECH TIPS



This month Simon Goodwin revisits several favorite subjects, including the CHEETAH Sound Sampler and SpecDrum, and the Amstrad Spectrum Plus Two.

CHEETAH CHEATED

After a few days fiddling, I have managed to load recordings made with the CHEETAH Sound Sampler into the SpecDrum rhythm synthesiser. This gives the SpecDrum a new lease of life — you can use absolutely any sound as if it was a drum!

For those who missed last month's column, the Sound Sampler lets you make a good-quality recording of any sound in your computer's memory. You can replay any part of the recording, perhaps changing the pitch or repeating sections. You can also use the sampler to process or distort sounds as they are made.

The SpecDrum is a similar device, but it lets you edit and

Over the last few years many of the most imaginative records have used weird percussion sounds — Peter Gabriel is especially keen on this. Now you can do the same — if you've got the imagination — with a humble Spectrum and £75 worth of hardware from CHEETAH.

Irritatingly, the manufacturers want to protect sales of their own percussion recordings, so they deliberately don't tell you how to make your own. This obstructive attitude is silly — it's an artificial limitation on the products. Besides, most people will want to use their own samples AND CHEETAH'S, as long as the professional recordings remain reasonably priced. So, I've worked out an easy way to make your own drum recordings.

INSTANT INSTRUMENTS

My 36 line program lets you load samples into your computer,

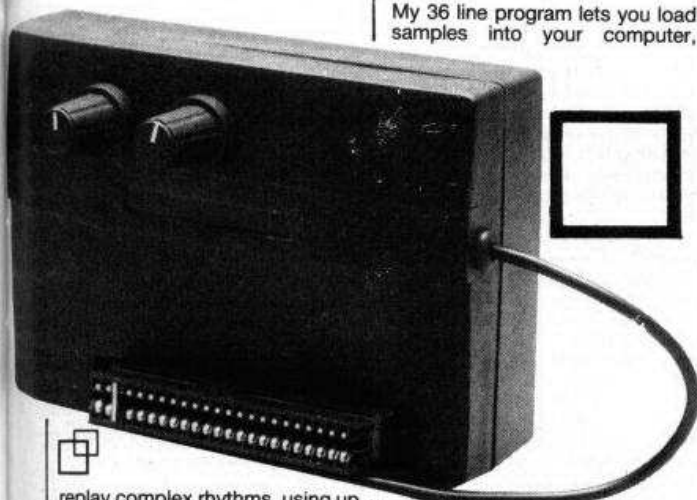

replay complex rhythms, using up to eight different drum sounds. The playback quality is quite excellent, but the SpecDrum can't record — it will only replay sounds from CHEETAH's own budget-priced but small catalogue.

replay them (without CHEETAH's software) and save any section as a drum file that loads directly into the SpecDrum system.

To start with, you must sample

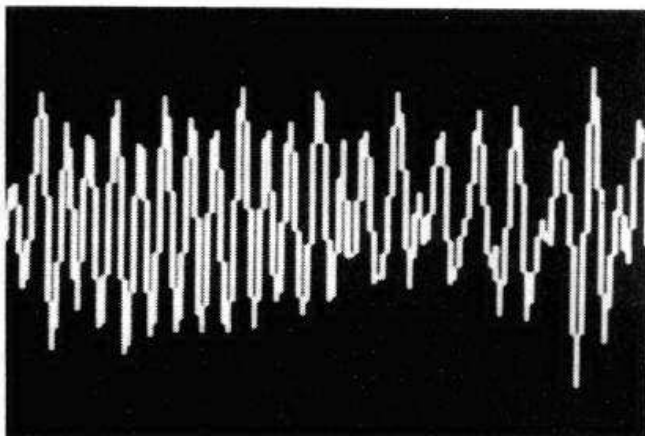

a sound and save the data on cassette. You don't have to configure the sample. The next step is to load my program and type RUN. Play the recorded sample; when it is found, the name and length will be printed on the screen. Other types of file are ignored.

The sampler lets you record more than a hundred 256 byte 'units' of sound, but the longest SpecDrum sound is restricted to 12 units, to allow room in memory for a kit of eight drums. You must tell the program the 'start page' from which your drum sound is to be taken.

Type 0, and press Enter, after loading a sample. You will hear the first 12 units of the sound. Type 12 to hear the next 12 units, and so on. Intermediate values work fine, and are useful to catch the exact beginning or end of a sound. You may hear a ticking sound if replay starts or ends midway through a noise, but you can minimise this by adjusting the start point.

Once you've found the right point you can create a file that the SpecDrum software will load. Type the start page number, and check that's the sound you want. Then type any negative number — minus one, for example. Rather tersely, the computer prints 'Enter to save'. Press Enter when your tape recorder is ready to record, and wait for the recordings to finish. The result — unless you mistyped the listing — is a drum file which you can load using the J 5 option on the SpecDrum menu.

It is up to you to record samples at the correct level. If this is wrong you will hear distortion when the sound is replayed, especially if other drums are used. You can get away with the maximum level allowed by the Sampler as long as you don't trigger several drums simultaneously. Those determined to emulate Keith Moon must reduce the level to avoid distortion. You can do this by re-sampling or using a Kit Editor.

The SpecDrum and the sampler use memory at different rates. It would be difficult to write new software that used the SpecDrum speed of 20,480 samples a second, but you don't really have to bother. You can get acceptable results by using 'half speed' on the sampler, which corresponds to

17,500 samples a second. Such samples are shifted a little higher in pitch when the drum machine plays them, but this doesn't matter with most percussive sounds. My software replays samples at the SpecDrum's speed.

NITTY GRITTY

The program is short but complicated — please type it carefully, and note that the variable name 'Len' should be entered as three separate characters, not a keyword. The program runs on any Spectrum with at least 48K of memory.

The code is based on my drum load/save/replay routines, which appeared in the June and October CRASHes. It is meant as a skeleton for you to build upon, although it works fine on its own. It can be used with the various drum-kit editor utilities which I've listed and mentioned over the last year.

In my last column I got the Sampler's port assignments the wrong way round — port 127 is the 'strobe' and 191 is used for input and output. This month's program replays through port 191, rather than port 31 as used by the SpecDrum. Change line 740 if you want to hear effects through the SpecDrum instead of the sampler. You can't plug both in at the same time, but apart from the port numbers — the output side of the sampler works just like the SpecDrum.

Sampler files use the same format as standard Spectrum tapes, this is so the Microdrive can handle them. CHEETAH however, have changed the first byte of the file header to 4. Normal files have types between 0 to 3, so samples won't LOAD normally. My machine code can read any type of file header. Line 350 throws out everything except samples.

Standard files can have ten-character names, but the SpecDrum only allows seven; the program ignores the last three characters when converting a sample into a drum file. As the code stands, drum files are 3K long and have type 130, so they can be loaded into the kit at positions 2, 3 or 4. For 2K samples, replace the 12's in lines 410 and 720 with 8's. Line 300 sets the file-type.

For the sake of simplicity, my program restricts the start of each sound to points at 256-byte intervals. You can easily change this — just POKE the offset, in bytes, from

the start of a page into Fx + 4 (for replay) and 32771 (for recording). The first 24 bytes of each sample contains configuration information, which is presently ignored.

THE HUMAN AERIAL

Last month I made the point that CHEETAH'S *Sound Sampler* is — potentially — much more than just a digital tape recorder. Since then I've found a few off-beat applications for the *Sampler*'s 'set level' option, which prints a graph corresponding to any change in input voltage. The entire screen is redrawn about once a second.



If you plug your Spectrum cassette lead into the sampler's input socket (where you would normally plug in a microphone), the graph will correspond to the signal picked up by the wire. The *Sampler* is very sensitive, so you may see some immediate fluctuations in the graph. These become much more obvious if you hold onto the other end of the lead. The sensitiv-

ity is highest when you hold the very end of the plug, but you may get a clearer signal if you touch both parts of the metal connector.

At this point I should explain that the signals which appear on the graph are very, very tiny, and are induced in your body whether or not you happen to be holding a computer lead. This experiment is perfectly safe, as long as you DON'T prod anything that would give you an electric shock whether or not you were connected to the *Sampler*.

The normal display should consist of a gentle wave, perhaps with ragged spikes along it. Adjust the sensitivity of the *Sampler* to stop the graph being 'clipped' at the top and bottom.

The biggest wave will correspond to the alternating electric field of the mains electricity. This field extends around any mains appliance — if you put your other hand near the Spectrum's mains adaptor you should see the graph get taller. Likewise, you can emphasise other signals — I got a clear graph, in time with music, when I turned my Hi-Fi up and held the speaker wire, or put my hand by the speaker. The signal from a Hi-Fi is much smaller than that from most mains appliances, so you may have to annoy the neighbours to get clear results!

Storage heaters, and similar electrical devices, regulate the amount of power they take by turning on and off many times a second. If you stand by a heater when it's on you'll see the usual mains wave, with chunks cut out of it as the heater turns on and off.



SPECTRUM OSCILLOSCOPE

You can also use the *Sampler* as a single-beam storage oscilloscope, as long as you're careful not to connect anything producing more than a volt or so of signal. I've been trying to get a cheap Commodore printer to talk to my other computers for a while; it uses a nasty non-standard serial bus, supposedly to stop you connecting the printer to a proper computer (or vice versa).

I connected the input of the

Sampler to the serial link (with the sensitivity turned right down) and got a borrowed Commodore computer to send a message. The *Sampler* recorded a clear graph of the signal, stored in a few pages of the Spectrum's RAM. I now know the data format — I've just got to write a program to impersonate it

I suspect that there are lots of other obscure applications for the *Sampler*, especially if new software is developed. Please write in if you have any bright ideas.

DRUMS PANNED

This month's £20 of software goes to Paul Bellamy, who has discovered how to make synchronised stereo recordings with a *SpecDrum* and two normal stereo tape decks. The process is essentially the same as the one I outlined in October, but you don't need a multitrack recorder.

Paul's diagrams should make the procedure clear. First you record the *SpecDrum* 'sync pulse' from the cassette port onto one channel of a stereo cassette deck. Then replay the pulses into the computer, using them to trigger

the drums for, say, the right channel. Use the second cassette deck, recording sync pulses on one channel and drums on the other. Replay the pulses from the second machine to trigger the left channel drums, and record both drum channels on the first tape deck.

Paul is planning to set up a *SpecDrum Users Group*, with free membership for enthusiasts. For details please write to him directly: Paul Bellamy, 304 Walkley Bank Road, Sheffield S6 5AR.

PLUS TWO

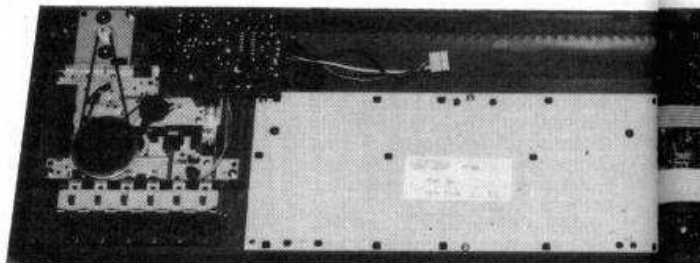

Since my first report on the Spectrum 128 Plus Two I have had an early machine at home for a few days. It was actually one of the computers from AMSTRAD'S stand at the PCW show. The machine was a prototype — at the time of writing, (late October) the production models were apparently still on a slow boat from Taiwan — but I'm worried that some of the flaws I found will crop up on later models.

My machine would not work properly with a colour TV — rolling horizontal stripes of colour appeared all over the place. The colour monitor display, however, was very clear. Amstrad say that they know nothing about the TV fault, but someone must be aware of it, as I found a seemingly unsuccessful bodge in the video circuitry. Two resistors and a capacitor were tacked under one corner of the circuit board. The old *Spectrum 128* worked well with TVs, so I don't expect this fault to persist, but please write in if your machine misbehaves in this way.

A potentially more annoying problem stems from the new box and arrangement of connectors on

the *Plus Two*. Several add-ons, including the Interface 1, won't fit the *Plus Two* unless you use an extension cable to keep the peripheral and the computer apart. Despite this, AMSTRAD advertise the machine as 'compatible with the Interface 1 and Microdrives'.

The CHEETAH add-ons, KEMPSTON'S joystick interface, the *Mirage Microdriver* and *Multiface 1* work OK, but they get in the way of the serial socket unless you use an extension cable.

I found three completely incompatible devices. CURRAH'S *Microspeech* stopped the computer dead. The cheap and cheerful VTX-5000 modem also fitted, but the machine ignored it. The same was true of DATEL'S *Sound Sampler*; a revised version is promised.

The moral of this story is simple — get suppliers to promise that products will work with your *Plus Two* before you part with any money. If possible, get an on-the-spot demonstration.

It should be easy enough for manufacturers to convert their products, but it will be a while before the new versions filter

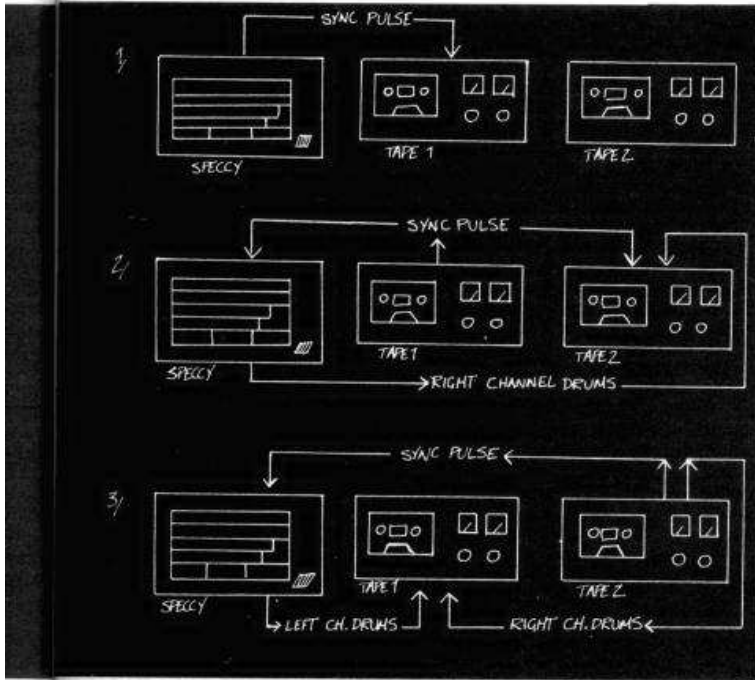

PROBLEMS

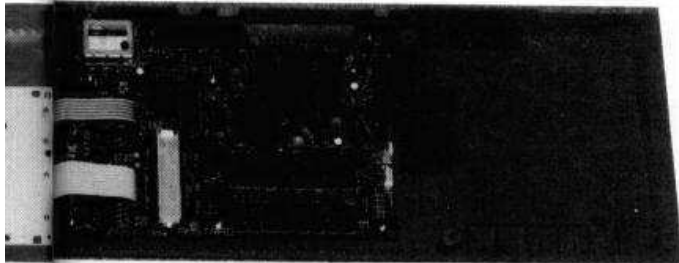

through to the shops. In the meantime you may find an extension card or cable very useful.

PLUS TWO CASSETTE PORT

The new grey Spectrum has a built-in tape recorder which seems to work quite well, but it doesn't really make up for the lack of a proper cassette port. I often find that I have to tweak the volume and tone settings of a recorder in order to load other people's tapes. There are no such controls on the Plus Two, so you can't do anything to counteract problems with badly-made recordings.

Even though there's an internal cassette drive, it would still be useful to be able to connect a separate recorder when handling really tricky tapes. Luckily this is quite easy, as long as you're willing to invalidate your guarantee by dismantling your machine.

Disconnect everything, then open up the Plus Two by undoing the screws in the base. Once you're inside you'll see that five

wires connect the cassette drive to the main circuit board. The red and black ones supply power, the brown one is a signal earth, and the blue and white ones correspond to the old Spectrum's EAR and MIC connectors.

All you have to do is add a 3.5mm socket in the wall of the case, and connect it to the appropriate wires, in parallel — in addition to the existing connections. The socket will have two connection-points. The one that touches the end of the cassette plug goes to the white cassette wire, and the other one connects to the brown wire.

This new socket can be used like the old Spectrum's EAR connector. The tones generated by SAVE are carried on the same wires, so you don't really need a separate MIC socket.

Be careful if you use a 'switched' earphone socket — you want the wires to be open-circuit when there's nothing plugged in, or the internal tape recorder won't work. Don't try to use two recorders at the same time — this is unlikely to cause damage but it's neither wise nor useful.

THE 64K SPECTRUM

I often receive letters from readers who want to know how to replace the Spectrum's 16K ROM with their own code; two people who have asked this recently are **Robert Darke** and **Bill Silvester**. It is not difficult to turn off the internal ROM — you just connect the edge-connector's ROMCS line to the 5 volt supply — but connecting a new ROM or RAM is rather tricky, unless you've done it before or you're an electronic whizz.

Last year **MIKRO-GEN** sold a few games that uses this technique to get 64K of code, including a 16K ROM, into a normal Spectrum. The *Micro-plus* didn't catch on, for all sorts of reasons unconnected with the technical merits of the idea. Unfortunately **MIKRO-GEN** have not got any spare stocks of their interface.

I've just heard from an electronics designer who has managed to fit an extra 16K of RAM inside the old Spectrum box. He's still checking that the modification will work on all versions of the computer, but in principle it looks as if his idea will solve this problem; the extra RAM overlays the ROM, so that PEEK reads the ROM and POKE writes to the RAM. You can turn the ROM off completely, and run with your own version of ZX BASIC or, in principle, anything else in the bottom 16K.

The inventor would be interested to hear of useful applications for this gadget, which should only cost about £20 if mass-produced. Please write to **TECH TIPS** if you've got any suggestions, and I'll pass them on.

GETTING SAMPLED SOUNDS INTO THE SPECTRUM The Simon Goodwin Way. . .

Main loader:

```
100 CLEAR 32767
110 LET Cas=32768: LET Fx=32785
120 FOR x=Cas TO Fx+23
130 READ c:POKE x,c: NEXT x
140 PRINT "Play sample tape."
150 POKE 32781,5: POKE 32780,86
160 GO SUB 300: GO SUB 350
170 POKE 32775,Len: POKE 32771,232
180 GO SUB 420: GO TO 500
```

Tape subroutines:

```
200 PRINT #0:"ENTER to save.": PAUSE 0
210 POKE 32774,B: POKE 32772,128
220 POKE 32781,4: POKE 32780,194
230 GO SUB 300: GO TO 400
300 POKE 32771,200: POKE 32968,130
310 POKE 32775,0: POKE 32777,0
320 RANDOMIZE USR Cas: RETURN
350 IF PEEK 32968<>4 THEN GO SUB 300: GO TO 350
360 FOR x=32969 TO 32978: PRINT CHR# PEEK x: NEXT x
370 LET Len=PEEK 32980
380 PRINT " sample length: ";Len#256: RETURN
400 POKE 32771,0: POKE 32772, PEEK(Fx+5)
410 POKE 32775,12
420 POKE 32777,255: POKE 32774,0
430 RANDOMIZE USR Cas: RETURN
```

Sound/Save controller:

```
500 INPUT "Enter start page (0-";Len);" :Page
510 IF Page<0 THEN GO SUB 200
520 IF Page>Len OR Page<0 THEN GO TO 500
530 PRINT #0:Page: PAUSE 0
540 POKE Fx+5,Page+129: RANDOMIZE USR Fx
550 PAUSE 0: GO TO 500
```

Machine code DATA:

```
700 DATA 175,221,33,0,128,17,17
710 DATA 0,62,0,55,205,0,0,245
720 DATA 193,201,17,0,12,33,0
730 DATA 129,243,6,9,16,254,62
740 DATA 128,134,211,191,35,27
750 DATA 122,179,32,241,251,201
```

COMING UP

I've got lots planned for next month's Christmas Special, including a review of **DATEL's Snapshot Microdrive conversion widget**. I'll also be reviewing **Genie** from **ROMANTIC ROBOT** — a monitor and disassembler that loads into their **Multiface**, and can be called up at any time at the press of a button (I meant to review **Genie** this month, but ran out of time).

If anyone you know owns a weird machine like a **Memotech** or **Einstein** they should be interested in the **Speculator** — a device that lets standard Spectrum game cassettes run on other computers! Full details of this **Techie's** dream next month, along with the obligatory review of the year and lots of hints 'n' tips.

In the meantime, please keep your own suggestions coming. Write to: **SIMON GOODWIN, TECH TIPS, CRASH TOWERS, 1-2 KING STREET, LUDLOW.**

24 HOUR

COMPUTER REPAIRS

AMSTRAD · SINCLAIR
QUALITY APPROVED REPAIR CENTRE

COMPUTER
SPARES



HOW TO GET YOUR SPECTRUM REPAIRED FOR ONLY £19.95

THE NO. 1 REPAIR CENTRE IN THE U.K. OTHERS FOLLOW

WHILE YOU WAIT SERVICE CALL FOR APPOINTMENT

SPECTRUM (only) KEYBOARD REPAIRS £8.95 THE CHEAPEST AROUND

WHY NOT COME AND VISIT US AT OUR NEW 2,500 SQ. FT. WORKSHOP. YOU CAN EVEN HAVE A CUP OF COFFEE WHILE YOU WAIT

MANCHESTER CITY CENTRE BRANCH NOW OPEN. CALL FOR DETAILS

SPECIAL OFFER!

Why not upgrade your ordinary Spectrum into the fantastic DK Tronics typewriter keyboard for only **£31.50** including fitting, VAT and return post and packing. Normal recommended retail price **£49.95**. Replacement printed DK Tronics key sets **£7.50** including post & packing.

Update Your Rubber Keyboard to a New Spectrum+

Fitted for only **£29.95 + £1.50** post & packing. (Also D.I.Y. Kit available for only **£23.00 + £1.50 p & p**)

Same day service LIMITED OFFER

SPECIAL OFFER!

Why not upgrade your 16K Spectrum to a 48K for as little as **£17.95** including VAT, post and packing. If you would like us to fit the kit for you, just send us **£19.95** which is a fully inclusive price to cover all costs including return postage. Full fitting instructions supplied with every kit. Issue 2 and 3 only.

16K to 48K UPGRADE KIT

TEN ★ REPAIR SERVICE

- ★ While you wait service including computer spare parts over the counter.
- ★ All computers fully overhauled and fully tested before return.
- ★ Fully insured for the return journey.
- ★ Fixed low price of **£19.95** including post, packing and VAT. (Not a between price of really up to **£30.00** which some of our competitors are quoting).
- ★ Discounts for schools and colleges.
- ★ Five top games worth **£33.00** for you to enjoy and play with every Spectrum repair.
- ★ We repair Commodore 64's, Vic 20's, Commodore 16's and Plus 4's.
- ★ The most up to date test equipment developed by us to fully test and find all faults within your computer.
- ★ Keyboard repairs, Spectrum rubber keyboards only **£8.95**.
- ★ 3 month written guarantee on all repairs.

EXTENSION RIBBON 56 Way ribbon cable to extend your ports for your peripherals **£10.95** plus **£1.50 p & p**

KEYBOARD TEMPLATES **£5.50** plus **£1.50 p & p**

RUBBER MAT **£6.50** plus **£1.50 p & p**

REPLACEMENT POWER SUPPLY

TRADE REPAIRS most welcome

TRADE ORDERS WELCOME

ZX81 SPARES NOW IN STOCK

BEST SERVICE - BEST PRICES!

ARE YOU ANOTHER CUSTOMER - fed up waiting weeks for your estimate?

Need your computer repaired fast? Then send it now to the **Number One Repair Company** in the U.K., or call in and see us at our fully equipped 2,500 square foot workshop, with all the **latest test equipment** available. You are more than welcome. We will repair your computer while you wait and help you with any of your technical problems. Commodore computers repaired for only **£35.00**. Please note we give you a **100% low fixed price of £19.95** which includes return post and packing, VAT, not a between price like some other Repair Companies offer. We don't ask you to send a cheque in for the maximum amount and shock you with repair bills **£30** upwards. Don't forget we are Amstrad approved for quality and speed, don't risk your computer to any other unauthorised repair centre. We don't just repair the fault and send your computer back, we give your computer a:

FREE OVERHAUL WITH EVERY REPAIR WE DO:-

We correct Colour, sound, Keyboard, Check the loading and saving chip, Put new feet on the base if required, Check for full memory, check all sockets including ear/mike and replace where needed. All for an inclusive price of **£19.95** including VAT, all parts, insurance and post and packing. No hidden extras whatsoever. We don't have to boast too much about our service as we have thousands of customers from all over the world highly delighted with our service. A first class reputation for speed and accuracy. Don't forget, we also now have a Service Branch in Manchester City Centre for while you wait service.

VideoVault D.I.Y. CORNER

We regret we cannot show all the components available. Just give us a call and we can quote you over the phone, delivery by 1st class post.

SPECTRUM SPARES		COMMODORE SPARES	
Z80B CPU	3.00	6526 - C.I.A.	19.00
4116 Rams	1.00	6510 - Processor	19.00
ZTX 650	0.60	6581 - Sid Chip	19.00
ZTX 213	0.60	906114 - House Keeper	19.00
Power Supply Transformers	9.95	901225 - Graphic Rom	19.00
ULA 6C001	16.50	901226 - Basic Rom	19.00
Rom	16.50	901227 - Kernel Rom	19.00
Keyboard membrane Spectrum	5.50	6569 - VIC	19.00
Keyboard membrane Spectrum Plus membrane	12.90	4164 Rams - Memory	3.00
Metal Templates	5.50	Power Supply Transformers	29.00
Keyboard Mats	5.50		
ZX81 membrane	5.00		
Service Manual	£30.00		

All our prices include VAT, but please add **£1.50** on each order to cover post, packing and handling charges.

VIDEOVAULT HEALTH WARNING!!!

Sending your computer to any other Repair Centre can seriously Damage its Health

VideoVault Ltd.

140 High Street West, Glossop, Derbyshire SK13 8HJ
Tel: 04574-66555/67761 Head office & access orders, queries, Manchester 061- 236 0376 while you wait repair centre only.

ORDER NOW!

OPEN 7 DAYS A WEEK MANCHESTER MON - SAT ONLY

5 GREAT FREE GAMES YOURS FREE WITH EVERY SPECTRUM REPAIR

£39.00

SPECIAL OFFER

COMMODORE POWER SUPPLY Commodore replacement power transformer **£29.00** plus **£1.50 p & p**

KEYBOARD MEMBRANES Spectrum keyboard membranes **£5.50** plus **£1.50 p & p**
Spectrum Plus spare keyboard membranes **£12.90** plus **£1.50 p & p**
ZX 81 membranes **£5.00** plus **£1.50 p & p**

FULLY REPAIRED AND TESTED ON MOST ADVANCED TEST EQUIPMENT IN EUROPE!

Copyright Videovault Ltd. No. 680132

Bill Scolding offers a CRASH course in understanding the amazing, incredible, stunning, revolutionary, unique, fast, furious and nearly realistic world of

SOFTWARE ADVERTISING

You've seen the film, you've read the advertisements, now buy the game. . . .

HYPE! sell!
sell! **PLUG!**



There it is on the shelf of your local software store, in its double cassette library case, with its glossy packaging and thrilling game description: "Startling action! Innovative game play! Revolutionary 3D graphics!" It only cost five pence short of a tanner, so you whip out a crisp Nightingale, scamper back to your trusty Spectrum, load it up and Bob's your uncle.

Except that Uncle Bob's looking suspiciously like a turkey, and the game's the absolute pits.

Where did you go wrong? Well, firstly, you didn't wait until our hardened games reviewers at CRASH Towers had given their expert opinions on it. You might not always agree with what they say, but at least you'll be better prepared before you part with the folding stuff.

And secondly, you believed everything said in the advertisements — or you were taken in by the promise of untold excitement that was suggested by the brilliant artwork on the advert and the packaging.

We're all guilty of falling for this at some time or another, and not just in the games software industry. If we weren't, then advertising wouldn't fulfil the vital role that it does. Without advertising, this magazine couldn't even exist — or not in the form it does, with over 160 pages and lots of glorious colour.

But that doesn't mean that you should always be taken in by what the ad-men say (or don't say), or that CRASH shouldn't occasionally bite the hand that feeds it, and put adverts under the same microscope that we use to examine games. . . .

So, here we go with another CRASH Reader Service: a (reasonably) light-hearted look at the pages which make up around a third of the magazine. At the end, there's a chance to have your say. Maybe the software publishers and advertising agencies might even listen to what you think. Then again, maybe not. . . .

SET LASERS TO STUN

Advertising is an expensive business, and highly competitive. Each advert is fighting against all the others, and against editorial to grab your attention. When there are 120 different martial arts games all going for your jugular and your pocket, how does any one software house make sure that their product is the one which gets noticed?

The secret lies in the Stun Factor — that elusive quality which makes the advert jump off the page and hit you right between the eyes for those precious seconds before you turn the page.

Sometimes ads rely on top quality artwork to deliver the death blow; at other times an arresting headline or catch phrase does the trick. Here are some of the slogans which have recently shouted from these pages:

"THE GAME THAT ROCKED AMERICA . . ."

"REACH NEW HEIGHTS IN TENSION!"

"NOW THE LEGEND COMES TO LIFE!",

"THE MAKING OF SOFTWARE HISTORY . . . AGAIN."

Can you identify the games belonging to these catchphrases? Either way, you'll have a good idea of how successful these slogans are. . . .

In the neverending quest for original, stunning, shock-packed headlines, the result of the advertising copywriter's efforts is often ludicrous or impenetrable; just what did **IMAGINE** mean by "THE GOTO BLASTERS!" in September's CRASH? Perhaps **OCEAN** were chancing it by asking, in their April spread, "WOW! HAVE I BEEN PLAYING GAMES!" when the obvious reply was "Not *Knight Rider* you haven't." And should **FIREBIRD** really proclaim proudly "IT'S WHAT YOU'VE COME TO EXPECT FROM FIREBIRD . . ."

But words alone are not enough to sell a game, and competent professional artists are now highly prized for their ability to take a game — often one not even prog-

rammed — and produce a visually exciting image for advert and packaging. **Bob Wakelin** — for **OCEAN** and **David Rowe** — for **QUICKSILVA**, **MELBOURNE HOUSE**, **BEYOND** and many, many others — are amongst the most well known, but the field is hotting up all over. The days of embarrassing juvenile scribbles are (almost) gone, and even **MIKRO-GEN** have ditched the nameless craftsman responsible for the *Wally and Herbert sketches* and with **Steinar** (*Stainless Steel*, *Frost Byte*) and our very own **Oli** (*Equinox*) are now producing some pretty dramatic adverts.

Just as the record industry made some young artists into household names — **Roger Dean** being one — so too is the comparatively immature software industry. There are probably some glossy software illustrations looking down from your bedroom wall as you read this.

LEGAL, DECENT, HONEST AND TRUTHFUL

Knowing that you're not going to be impressed just by pretty pictures, some publishers attempt to win you over with a glowing game description — known as the advertising copy or **BLURB**. This has the same purpose as the stuff you read on the back of paperbacks, and is just about as reliable.

Blurbs are usually crammed with well-worn phrases like 'stunningly realistic', 'state-of-the-art' and 'fully animated'. All this is fairly meaningless as (a) the copywriter hasn't always seen the game, and (b) he's not likely to write 'yet another *Knight Lore* rip-off' or 'you'll be amazed at the colour clash'.

As a rule of thumb, you can

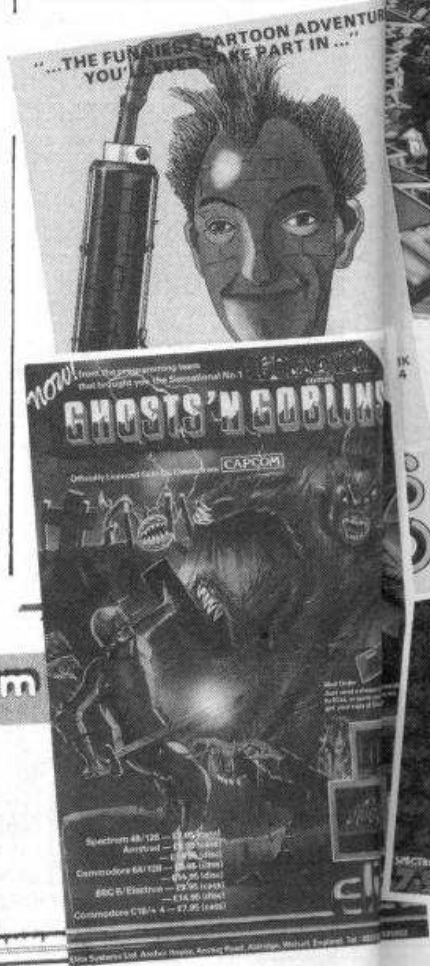

HOT
gerry the germ



ADS HYPERMARKETING!

MONEY

assume that any game described as 'unique' or the 'ultimate' is actually neither, and if the copywriter had had to fall back on 'fast and furious' then you can be certain that the game he's describing is bereft of any original or outstanding feature whatsoever.

The more informative blurbs are those which describe the plot, graphics and gameplay in factual terms, minus hysteria. They are also the most boring to read, which is why you don't see them on adverts too frequently.

Most informative of all are the quotes taken from magazine reviews which appear on the ads — but these should be treated with caution. Disregard anything inside quotation marks which is not attributed to a specific writer or magazine — the chances are that the publishers themselves have said it. **ADDICTIVE GAMES** are old hands at this, though at least they have the honesty to admit that it's Managing Director **Kevin Toms** who's responsible for this (utterly impartial) accolade: "Headcoach will become for American Football

what my *Football Manager* has been for soccer fans — unbeatable."

Quotes can be taken out of context, too. Have a guess what a desperate advertiser might extract from the following review: "Wow! I thought at first, what incredible graphics! After a few seconds, however, I realised that the game was 100% unplayable." Yep, they sure as hell aren't going to put "unplayable" in inch high letters across the top of the advert!

And, of course, reviews don't usually appear until after the game is already completed, so either the software house has to go to the expense of designing a new advert, stuffed with reviewers' raves, or else they have to use quotes from previews. More often than not, they decide it's cheaper, and safer, to stick to their own exciting prose.

THE CAMERA CAN'T LIE

A screen shot is worth a thousand words. At a glance you can tell

whether those 'state-of-the-art' graphics are the same old monochromatic matchstick men, or the 'totally realistic simulation' is the usual bunch of pipe-cleaner tanks advancing across a blackboard desert.

And it's precisely because such photos confirm your worst suspicions that most adverts don't feature them. Those that do display an uncharacteristic confidence on the part of the publishers that the graphics really are something to shout about. Even then it's advisable to look for the small print: 'Actual screen shots from the Atari ST' might not appear quite so wonderful when they've been crammed into 48K to attribute problems.

There's another very good reason why software houses don't always put screen shots on their ads.

Because there aren't any graphics to photograph.

JUMPING THE GUN

To take screen shots, you've got to have some computer graphics already up and running. And to have graphics, you've got to have started programming. Once in a while a software house takes the bold step of advertising a game which, surprisingly, EXISTS. In other words, the team of crack programmers have already got their heads down and are making progress.

But there is a widely-held belief in this industry that a good title alone is enough to sell software by the bucketful, and often the rights to that title, if it's based on a book, film, TV series or amusement arcade game, will cost more than all the programming, packaging and marketing of the software put together.

Consequently, as soon as the deal has been signed, some flash artwork is quickly cobbled together and the first advert appears — sometimes over a year before the game sees the light of day. That ad will contain no game description, no plot, no screen shots, because the publishers haven't got the foggiest idea of what the game is going to be like. They're lucky if they've even decided on a price. But none of that matters, because they believe that the TITLE is so thrilling that you'll be queueing up just to buy a blank cassette with those magic words printed on it. Or so the theory goes.

And so the theory goes badly wrong, too. Jumping the gun has caused more than one successful company to bite the dust when, faced with the heavy cost of continual advertising, their programmers are still bravely trying to convert a best-selling 2000-page novel into an arcade game which bears some minimal relevance to the source material.

Knight Rider, Street Hawk, Popeye, Superman, Dr Who, Asterix . . . These titles should be engraved on the wallets of all software publishers in search of the elusive licence to print money.

Such golden eggs have a protruded and painful delivery, often hatching into turkeys, and the whole thing can take so long that everyone loses interest in it.

Mind you, the adverts for games such as these are the most attractive of the lot. Fabulous illustrations, uncluttered with messy text and muzzy screen shots, and after a few months they're so familiar they're like old friends. But do they sell games?

THE BOTTOM LINE

Where does all this get us?

If you want to make sure that you never buy another *Great Space Race* or *World Cup Carnival*, wait for games to be reviewed, and then decide.

But if you just can't wait to rush out and buy something, then take a long hard look at the adverts, and ask yourself:

If the graphics are really revolutionary, then why aren't there any on the ad?

If a game is truly remarkable, then how come it's described in the same amazing, stunning, state-of-the-art clichés used by everyone else?

If a quote isn't credited, then who said it, and why?

Have I really got enough spare cash to buy a game costing £9.95 about which I know nothing except that it has the same title as a TV series and there's a very nice picture on the cover?

Over to you

Now it's your turn.

Thumb back through the last 12 month's issues of CRASH, starting with January 1986, and pick out the one advert which you think stands head and shoulders above the rest. Maybe you reckon that the presentation is the best, or the blurb is well-written, or the whole thing tells you all you need to know about the game. Whatever your reasons, jot them down BRIEFLY together with your nomination, and the date of an issue in which it appeared.

And while you're about it, why not choose the worst ad of the year, the one with tacky artwork, or banal copy, or just straightforward lies? Again, give the reasons behind your choice.

Send your nominations to: THE WORM TURNS, CRASH Towers, 1/2 King Street, Ludlow, Shropshire, SY8 1AQ, to arrive by December 31st, 1986. (Don't forget to vote in the CRASH Readers' Awards ballot in the Christmas Special as well, mind.) We'll publish a selection of the best nominations, with some of your choice comments, if they're printable. Should make interesting reading for some software houses who think they know their market.

To help you on your way, we've reviewed some classic adverts: we've tried to find some which commit many of the sins and excesses described in this article, as well as some which are relatively free of them.

But we're sure that you can dig out some better examples. Send them in.



LEGEND OF THE AMAZON WOMEN

Producer: **US Gold**

A strong contender for the most poorly drawn ad in software history — though the frog's exploding genitals in **MIKRO-GEN's** *Witch's Cauldron* are still fondly remembered by many. At first glance the graphics are merely abysmal, but closer scrutiny reveals an ignorance of the female anatomy which still baffles to this day.

The accompanying blurb is a masterpiece of suggestion. It waxes lyrical about the 'unknown' location, the 'ghostlike images' of wild women, the 'unimaginable combat and untold adventure'. Presumably the game hadn't been

written when this advert went into print. Pity the copywriter didn't have the benefit of LMLWD, too

... One of those rare ads where the artist's impression is actually worse than the graphics of the game, *Legend of the Amazon Women* is also remarkable in that few will ever forget it. Perhaps it is, therefore, also one of the most successful ads in software history.

Graphics	5%
Stun Factor	95%
Blurb	10%
Informative content	10%
Overall	90%

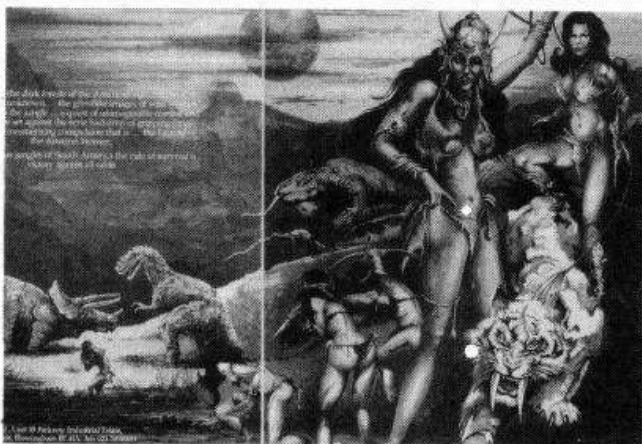

SAMANTHA FOX STRIP POKER

Producer: **Martech**

What do you do if you've got a mediocre card game which you want to unload on an impressionable young audience? Simple — just add the tantalising words 'Samantha Fox Strip' and we're all drooling from Edinburgh to Ealing.

Particularly unsavoury in its 'nudge-nudge, wink-wink' teasing blurb, the advert is nevertheless successful in revealing absolutely zilch about the game. We're told that it includes 'Video Digitised Pictures' but do they show us one? Not on your life, mate. If they had done, then the full horror of pixelated Sam baring her dotty attributes would have put even the most lecherous off the game.

Curiously, **MARTECH** attempt to promote the 'added bonus' of *International 7 Card Stud* in the bottom righthand corner, which they claim is 'Probably the most powerful simulation ever written for a home computer.' It says a lot about **MARTECH** that they feel the only way to sell this exceptional simulation is to hitch it to a game riding on a pair of mammoth jugs.

Sam Fox. Probably the most powerful stimulation ever to appear on a home computer.

Graphics	30%
Stun Factor	70%
Blurb	15%
Informative content	5%
Overall	10%

THE GREAT ESCAPE

Producer: **Ocean**

Such is the consistent quality of **Bob Wakelin's** artwork, now the hallmark of **OCEAN's** adverts, that it is difficult to single out any one illustration as being particularly

confidence in the graphics as they've actually included three shots in the ad. These are significantly missing from some other recent **OCEAN** promotions. In all other respects, however, there's not a hint of a game description. Would you buy *The Great Escape*

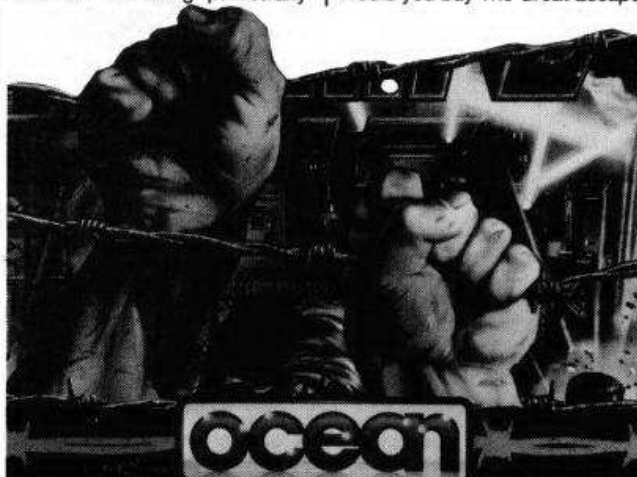

outstanding. *The Great Escape* is one of his best, though, because unlike some of his other work (*Nightmare Rally*, *Mag Max*), it is uncluttered, relying on a simple image — hands gripping barbed wire — to convey the spirit of the game.

OCEAN has, presumably, some

purely on the strength of this ad? Still, it's a nice picture.

Graphics	90%
Stun Factor	80%
Blurb	0%
Informative content	40%
Overall	70%

TOMAHAWK

Producer: **Digital Integration**

Here's an advert that strives to be both eye-catching and informative, with moderate success.

It's got a great illustration to begin with. And it's also got some copywriting which isn't too exaggerated, except for a momentary lapse with 'stunningly realistic' (you might want to question the 'authentic battlefield conditions' too). Beneath all this is a list of game features, dotted with evocative terms like 'Doppler navigation', and there's also a couple of typical screen shots for good measure, though they're hardly crystal

clear.

Maybe there's too much text, too much going on... But then again, most **CRASH** readers probably scrutinise the ads with the same devotion as they do the editorial, and enjoy an advert with lots of copy. And at least the lads at **DI** are giving a pretty good idea of what's in the game.

The **CRASH** Smash seal of approval helps, of course.

Graphics	80%
Stun Factor	65%
Blurb	70%
Informative content	80%
Overall	85%



BAZOOKA BILL



ARCADE

COMMODORE

£9.95

SPECTRUM

£8.95

Arcade Machine Ltd. software is distributed by Melbourne House Publishers Ltd.
All enquiries and orders to: 60 High Street Hampton Wick Kingston Upon Thames Surrey KT1 4DB. Telephone: (01) 943 3911 Telex: 935425 MELRSO Facs: (01) 943 2688

THE CRASH CHRISTMAS SPECIAL

REVIEWS, NEWS, FEATURES, PREVIEWS
COMPETITIONS, LM, AND LOTS A GOODIES!
A REAL MONSTER READ FOR THE FESTIVE SEASON!

INCLUDES A FREE COPY OF

LM

Issue Zero of the Bright New Magazine That Bears
Lloyd's Initials isn't available in the shops and contains a
host of goodies, including:

- **SUPERMAN IV — Special Effects**
- **BOWIE — The New Man**
- **IAN RUSH — Footballer-Millionaire**
- **Skiing Holidays**
- **BIG COUNTRY**
- **THE STRANGLERS**
- **1986 — The Year That Was**
- **HUNTER S MINSON GOES TO VENICE!**



**DON'T BE LEFT IN THE COLD!
SNUGGLE UP WITH A COPY OF THE CRASH CHRISTMAS SPECIAL
ORDER IT — BEFORE IT'S TOO LATE!**

Use the coupon on Page Eight if you want to make your Newsagent's life easy. . . .

Many eons ago, an advanced technologically oriented civilization was forced to evacuate the Earth prior to the Ice Age. Now, these Xevious people are returning to reclaim their heritage through conquest.

From the controls of your Solvalu super spacecraft, you must defend the Earth from takeover by the Xevious invaders!

Flying a search and destroy mission, you will cruise over the scrolling landscape, bombing Xevious ground entrenchments and zapping the air targets that come into range. Easy. But now look out for the flying mirrors — impossible to

destroy; a collision will spell certain death!

In the event of your surviving wave after wave of enemy onslaught you will encounter the controlling force of the Xevious offensive; the Andor Genesis Mother Ship! This

is your goal. A direct hit to her central reactor will disable her, but do not be lulled into a false sense

of security. Xevious forces will soon re-appear to renew their attacks with increased

determination!



Another classic Atari coin-op hits the 64! ZZAP 64

XEVIOUS

XEVIOUS



ATARI

Commodore 64 £9.99 CASS. £14.99 DISK.

Spectrum 48K £7.99 CASS.

Amstrad £9.99 CASS. £14.99 DISK.

*Xevious is engineered and designed by Namco Ltd. Manufactured under license by Atari Inc. and U.S. Gold, 2/3 Holford Way, Holford, Birmingham B6 7AX.

1986
PBM MAILBOX



Here's another extra large portion of PBM news 'n' views. This month Brendon Kavanagh tries out a new weapon, gives us some hints on Starglobe and the Forum goes football crazy.

A SHINY NEW WEAPON

The *Weapon* is a science fiction based wargame designed by the US gaming company, 4SIGHT, and moderated in the UK by HARROW POSTAL GAMES (of, er, Harrow) under a very strict licensing deal. A game for up to 15 players, *The Weapon* is one of the most complex games to be mentioned within these pages so far.

The player is ruler of a technological world which has recently discovered hyperspace travel, opening routes to the distant worlds for the first ever time. You must use your squadrons of starships to explore and conquer game space, mapped out as a 20 by 20 grid of hexes. Hexes may be empty, dangerously cloudy, or occupied by worlds.

WORLDS

Worlds have several game functions: some produce rare crystals required to construct and operate THE WEAPON (a very gruesome device), some produce economic output, and others can be mined for minerals. Worlds are a very important part of this game, since it's points system is partially based on the worlds you own (and for how long you have held them). Thus, worlds must be defended by your Star Troopers while they produce goods for trade and cash for your coffers.

STARSHIPS

All players start the game with a small squadron of vessels, but as the game progresses you may design and construct more, and more, and more.

THE OBJECT

The somewhat bland object of *The Weapon* is to amass as many

points as possible before the game ends. Games last for between 15 and 30 turns, so you never quite know how much time you have left to raid all those planets within fighter range... As well as for holding worlds, points are gained by destroying enemy starships in combat. Incidentally, you lose points if you lose any ships in battle!

HOW D'JA WIN

To play *The Weapon*, you must (as in all games) utilise your limited resources to their maximum potential. Basically, you must discover, conquer and defend new worlds, maintain economic growth within your empire, produce crystals for use in THE WEAPON, develop your combat and navigational expertise (ie. fight and move about!), establish trade routes to your benefit, and engage in diplomacy.

The more successful *The Weapon* players have amassed points by working together in small alliances, called treaties. Treaties can be very beneficial but they are also risky: a treaty means that your automatic defences will trust someone who may not necessarily be all to trustworthy...

STRATEGY

In play, the game is VERY strategic and exceedingly fast moving. You are deeply engrossed in the game within three turns. Being something of an advanced hybrid of *Capitol* and *Vorcon Wars*, *The Weapon* requires a lot of careful diplomacy to enjoy while if your battle strategies are poor then you won't have too many worlds to be diplomatic over!

If you have never played (or won) a strategic game then I doubt you would enjoy playing THE WEAPON. However, very strong

strategic aspects will appeal of readers of *Frontline*, and any experienced PBMs vaguely interested.

LOW PRICE

The Weapon is quite a low priced game, for its type. As a special offer to CRASH readers, Jim Gibson of HPG has agreed to reduce startup prices. The rule book will cost £1.00 instead of the usual £1.50. A set up and one free turn will cost £4.00 rather than £5.00 and the cost of the first five paid turns has been halved to £1.00 each

Each turn thereafter costs the usual £2.00, the game being played on a 14 day turnaround. Be sure to mention CRASH in all correspondence!

I strongly recommend you to buy the rule book before you set up in *The Weapon*, as it is a fairly complex creation (in monosyllabic terms, it's HARD). If you are grasped by what you read, play. If not then pass the book onto a friend.

If you are interested in this offer, write to: THE WEAPON CRASH ENQUIRY, Harrow Postal Games, 161 Butler Road, Harrow, Middlesex, HA1 4DX.

Part of the order sheet for THE WEAPON...

Game Number 101 Turn Number 8 Due Date 14 SEP 86 Number of Orders 55
 Code Name SLEED Signature [Signature] Account Number 100

1) UPGRADE NETWORK? (Circle if yes)
2) CANCEL TREATIES
 CANCEL TREATY WITH _____ CANCEL TREATY WITH _____
3) MAKE TREATIES
 MAKE TREATY WITH _____ MAKE TREATY WITH _____

4) SHIP UPGRADE
 UPGRADE S 253 UPGRADE S _____ UPGRADE S _____ UPGRADE S _____ UPGRADE S _____

5) UNLOAD (MR, TR, DC, KC, ZC)
 UNLOAD 90 TR FROM S 133 UNLOAD _____ FROM S _____ UNLOAD _____ FROM S _____
 UNLOAD 20 TR FROM S 126 UNLOAD _____ FROM S _____ UNLOAD _____ FROM S _____
 UNLOAD 70 TR FROM S 192 UNLOAD _____ FROM S _____ UNLOAD _____ FROM S _____
 UNLOAD _____ FROM S _____ UNLOAD _____ FROM S _____ UNLOAD _____ FROM S _____
 UNLOAD _____ FROM S _____ UNLOAD _____ FROM S _____ UNLOAD _____ FROM S _____
 UNLOAD _____ FROM S _____ UNLOAD _____ FROM S _____ UNLOAD _____ FROM S _____
 UNLOAD _____ FROM S _____ UNLOAD _____ FROM S _____ UNLOAD _____ FROM S _____

6) TRAIN STAR TROOPERS AND LOAD ONTO SHIP
 TRAIN _____ TR FOR S _____ TRAIN _____ TR FOR S _____ TRAIN _____ TR FOR S _____ TRAIN _____ TR FOR S _____
 TRAIN _____ TR FOR S _____ TRAIN _____ TR FOR S _____ TRAIN _____ TR FOR S _____ TRAIN _____ TR FOR S _____
 TRAIN _____ TR FOR S _____ TRAIN _____ TR FOR S _____ TRAIN _____ TR FOR S _____ TRAIN _____ TR FOR S _____
 TRAIN _____ TR FOR S _____ TRAIN _____ TR FOR S _____ TRAIN _____ TR FOR S _____ TRAIN _____ TR FOR S _____

7) LOAD (MR, TR, DC, KC, ZC)
 LOAD 2 KC ONTO S 418 LOAD _____ ONTO S _____ LOAD _____ ONTO S _____
 LOAD 2 KC ONTO S 418 LOAD _____ ONTO S _____ LOAD _____ ONTO S _____
 LOAD 4 DC ONTO S 398 LOAD _____ ONTO S _____ LOAD _____ ONTO S _____
 LOAD _____ ONTO S _____ LOAD _____ ONTO S _____ LOAD _____ ONTO S _____

8) TRAIN STAR TROOPERS FOR WORLD DEFENSE
 TRAIN 22 TR FOR W 65 TRAIN _____ TR FOR W _____ TRAIN _____ TR FOR W _____ TRAIN _____ TR FOR W _____
 TRAIN 15 TR FOR W 81 TRAIN _____ TR FOR W _____ TRAIN _____ TR FOR W _____ TRAIN _____ TR FOR W _____
 TRAIN _____ TR FOR W _____ TRAIN _____ TR FOR W _____ TRAIN _____ TR FOR W _____ TRAIN _____ TR FOR W _____
 TRAIN _____ TR FOR W _____ TRAIN _____ TR FOR W _____ TRAIN _____ TR FOR W _____ TRAIN _____ TR FOR W _____
 TRAIN _____ TR FOR W _____ TRAIN _____ TR FOR W _____ TRAIN _____ TR FOR W _____ TRAIN _____ TR FOR W _____
 TRAIN _____ TR FOR W _____ TRAIN _____ TR FOR W _____ TRAIN _____ TR FOR W _____ TRAIN _____ TR FOR W _____

9) PICK UP DEVICES (WG, PR, BR1, BR2, BR3, BR4, BR5, BR6)
 S _____ PICK UP _____ S _____ PICK UP _____ S _____ PICK UP _____ S _____ PICK UP _____
 S _____ PICK UP _____ S _____ PICK UP _____ S _____ PICK UP _____ S _____ PICK UP _____

10) SELF DESTRUCT (WG, PR, BR1, BR2, BR3, BR4, BR5, BR6)
 SELF DESTRUCT _____ IN SECTOR _____ SELF DESTRUCT _____ IN SECTOR _____ SELF DESTRUCT _____ IN SECTOR _____
 SELF DESTRUCT _____ IN SECTOR _____ SELF DESTRUCT _____ IN SECTOR _____ SELF DESTRUCT _____ IN SECTOR _____

11) BUILD SHIPS
 BUILD 1 CLASS 3 SHIPS AT W 172 BUILD _____ CLASS _____ SHIPS AT W _____ BUILD _____ CLASS _____ SHIPS AT W _____
 BUILD 1 CLASS 3 SHIPS AT W 824 BUILD _____ CLASS _____ SHIPS AT W _____ BUILD _____ CLASS _____ SHIPS AT W _____

... and a section of the turn printout received at Chateau Kavanagh as a result of playing THE WEAPON

```

** 3 SHIP(S) IN SECTOR 917 **
5203 ( 5 ) SLEED 1 885 1 1/0 0 0/0 1 8 1 0 0 1 0 1
5428 (11) 7 SLEED 1 0 1 8/1 0 0/0 1 8 1 10 1 0 1 0 1 38C, 28C, 100R
START: 81 MOVEMENT: 1, 2, 7 = 272, 381, 917
5448 (11) 1 SLEED 1 9 1 122 1 1/1 1 8 1 8 1 0 1 0 1 28C
START: 792 MOVEMENT: 4 = 917

** 3 SHIP(S) IN SECTOR 946 **
893 (11) 1 SLEED 1 0 1 5/4 1 0/0 1 1 1 0 1 0 1 20 1
START: 415 MOVEMENT: 1, 2, 6 = 582, 62, 746
5333 ( 1 ) FALCON 1 28 1 5 1 0 1 1 1 0 1 0 1 0 1
5489 ( 2 ) ALPHA 1 45 1 15 1 0 1 1 1 0 1 0 1 25 1

```

FORTRESS REPORT

W05 TARGETS: 150 BY AUTO NETS
 W08 TARGETS: 7 SH -> 350
 W55 TARGETS: 8 BY AUTO NETS
 W53 TARGETS: 12 SH AUTO NETS

ACTIVATED PROBES, BARRIERS, AND WARP GATES

PROBES: TOTAL = 1 SECTOR(S) 310/2
 BARRIERS: TOTAL = 9 SECTOR(S) 844-4, 844-5, 917-1, 917-2, 917-3, 917-4, 917-5, 917-6
 GATES: TOTAL = 3 SECTOR(S) 917, 310, 424

PLAYERS AND SCORES

[VODAN] = 528, [ALPHA] = 151, [EUMAKT] = 1264, [FALCON] = 2296
 [DECKT] = 1745, [BRAVO] = 1324, [TRADER] = 982, [KONKA] = 981

ORDERS IN ERROR

BUILD 2 FORTRESSES AT W016 (- Insufficient resources - not processed.)
 SL3 -DC FR W418 TO S335 FOR 1500 (- No valid reciprocating buy/sell order.)
 BY3 -ZC FR S335 TO S418 FOR 1500 (- No valid reciprocating buy/sell order.)

*Let the good
times roll!*

BOBBY BEARING

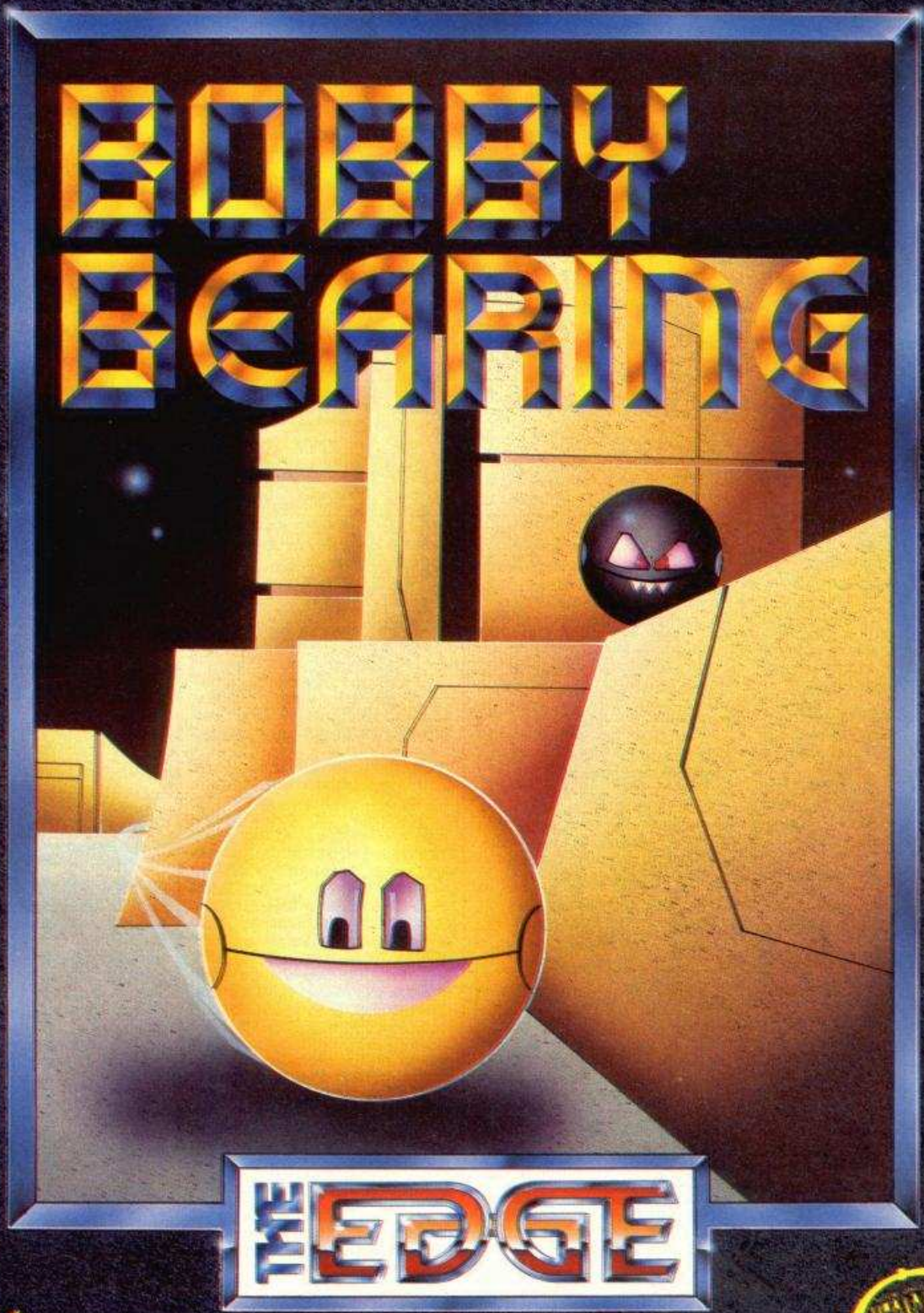

EDGE

GAME OF
THE MONTH
C&VG

EDGE

A
CRASH
SMASH

"I love this game ... if you don't buy this, throw away your Spectrum!" C&VG Game of the Month August 1986.

"Bobby Bearing is very nearly perfect. This may sound a bit over the top but this game deserves a whole string of superlatives." ZX Computing August 1986.

Spectrum / Commodore 64 / Amstrad

Konami®

SHAO-LIN'S ROAD™

'The arcade hit...
...in your home!'

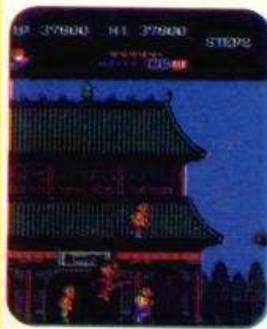
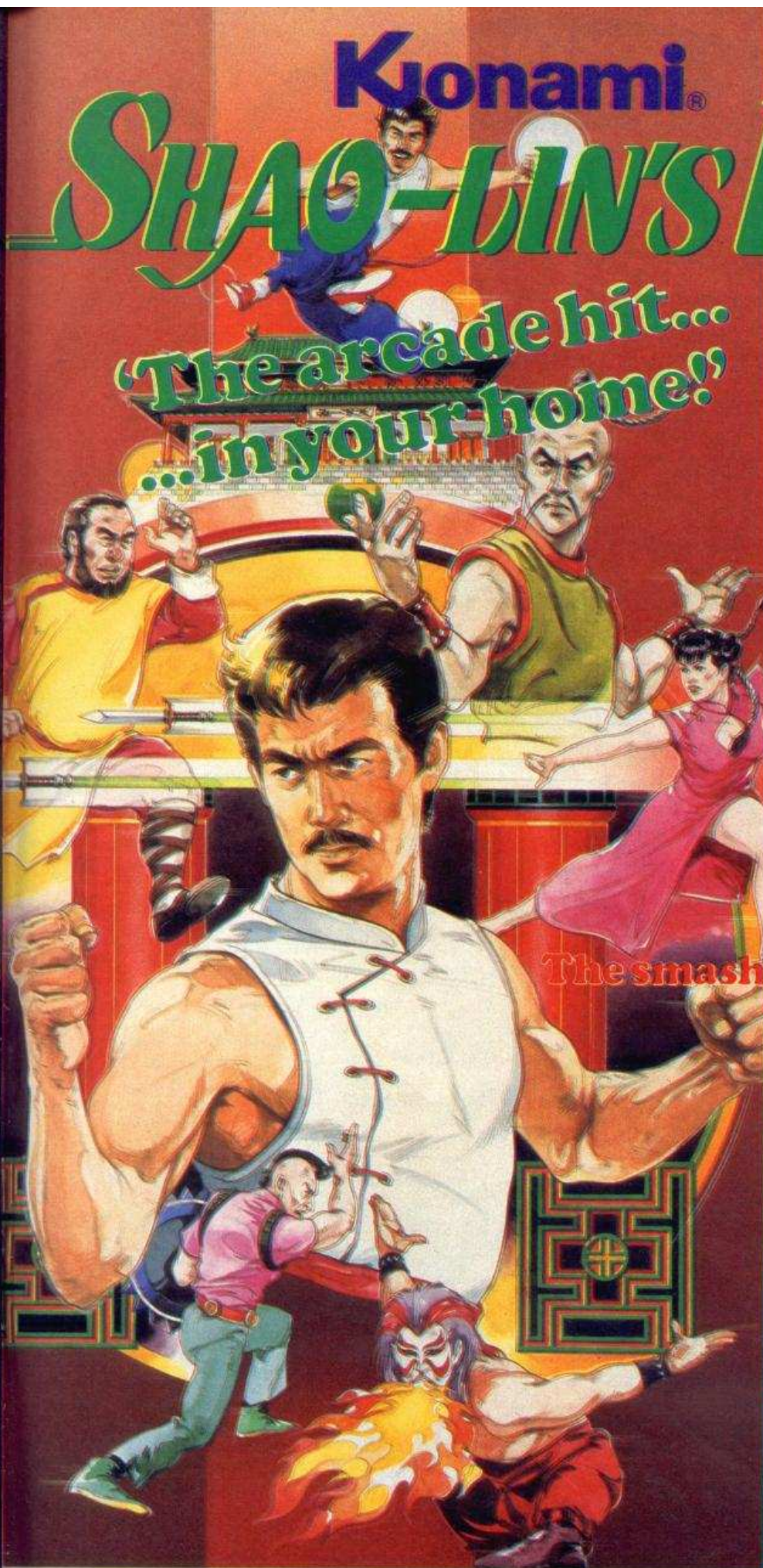

Screen shots from
arcade version - home
micro versions may differ

The smash hit follow up to
'Yie Ar Kung-Fu'

Spectrum
Commodore 64
and
Amstrad versions
coming soon.

Our hero has finally
mastered the secret
martial art "CHIN'S
SHAO-LIN" but is trapped
by triad gangs. With kicks
and other secret powers,
escape from and travel
SHAO-LIN'S road to
freedom!



Published under licence by The Edge, 36/38 Southampton Street, London WC2.
Tel: (01) 831 1801 TX: 892379.

KONAMI'S
COIN-OP HITS

FIVE GREAT ARCADE GAMES FOR THE PRICE OF ONE

IT MUST BE CHRISTMAS

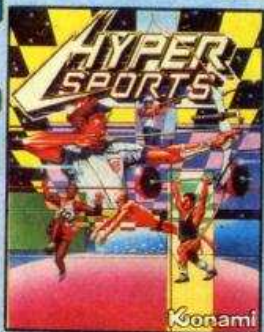

Konami

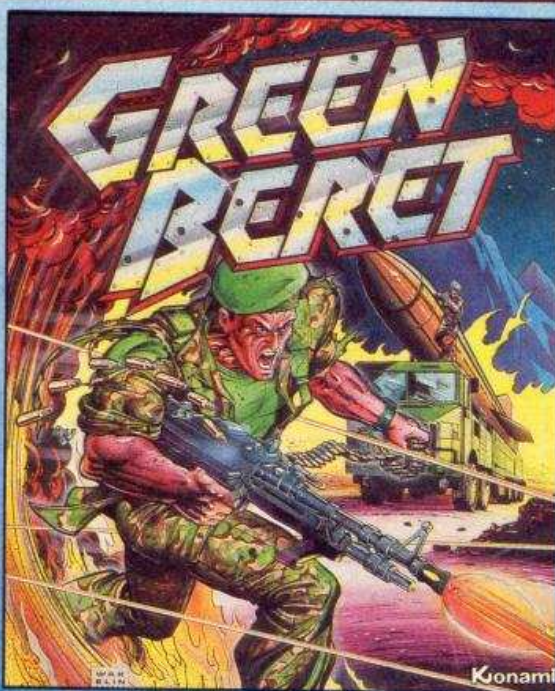

Konami

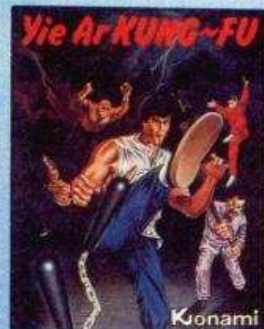

Konami

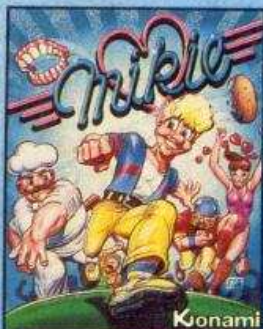

Konami

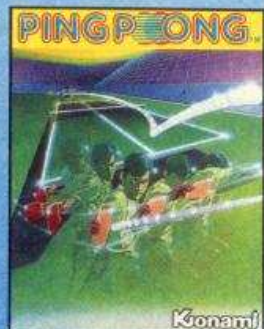

Konami



KONAMI'S COIN-OP HITS

	Cassette	Disk
SPECTRUM	£9.95	-
COMMODORE	£9.95	£14.95
AMSTRAD	£9.95	£14.95

Twin Cassette Pack

Imagine
"the name
of the game"

Imagine Software (1984) Limited, 6 Central Street, Manchester M2 5NS. Telephone: 061-834 3939 Telex: 669977.

Distributed in France by Ocean France. Telephone: 93-42-2144. Distributed in Germany by Software Distribution. 1104 1984

FRONTLINE

with Sean Masterson

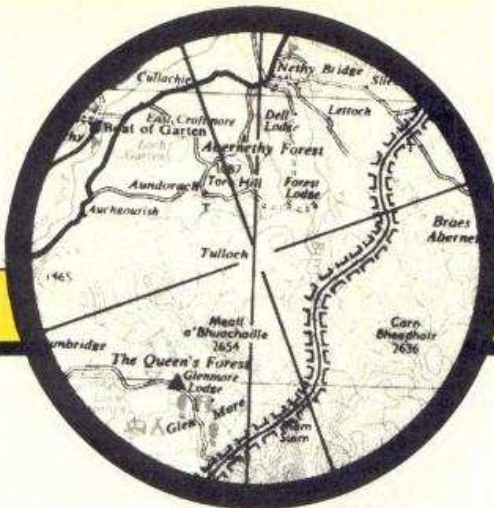

SQUONK*

Lights are on again. No fear of anything leaping out of the shadows to attack me. Weapons can be unloaded and put away. The contents of the room are strange as well. Peaceful, unimposing — and quiet. The war is over. Time to enjoy life and appreciate its subtleties.

No more adventures. No more conquests.

The war is over.

Before I go home, I'd like to introduce you to someone who's going to further the cause. Enter Miss Philippa Irving. Oxford student extraordinaire, media SF fan and computer game addict. Philippa has interests in both adventure and strategy gaming and is well suited to the job. I'm handing over all your letters, software and other related doobies in time for the February issue. There will be no FRONTLINE next issue and, if you haven't already guessed, I'm leaving.

And with a bit of luck, Philippa should end up reviewing something of mine. One day. Thanks to everyone who wrote (hope the support continues) and to the software houses for sending me oodles of games to review. It's all been fun. But I've opted for a change of tune. Have an interesting new year . . .

*The squonk is a sad creature who, when frightened, cries until all that remains is a pool of tears. Not surprisingly, this has led to his extinction.

SWORDS OF BANE

Producer: CCS
Retail Price: £7.95
Author: Astros Productions

ccs dominate the review section this month and this is their latest release in a rapidly expanding range. Unlike most of their releases to date, ccs have brought their strategy game expertise into the realms of fantasy. It's good to see a change. Fantasy wargaming opens up a whole range of opportunities. You are cast in the role of Head of the Imperial Guard and command a mixed army of warriors and wizards against hordes of terrible monsters.

The game is interesting also because on the B side of the cassette, there's an expanded game for the 128K Spectrum. This version has two extra scenarios and maps to take advantage of the extra memory. The game boasts a double cassette box, glossy instructions with full map diagrams and an icon driven control system. Sounds impressive — but how does it play?

Well the screen is standard fare for ccs, being large and scrollable (what a terrible adjective) within a window. Two other windows allow

the statistics display for the unit characters currently in action (ie movement points and stamina). At the bottom of the screen, icons are displayed.

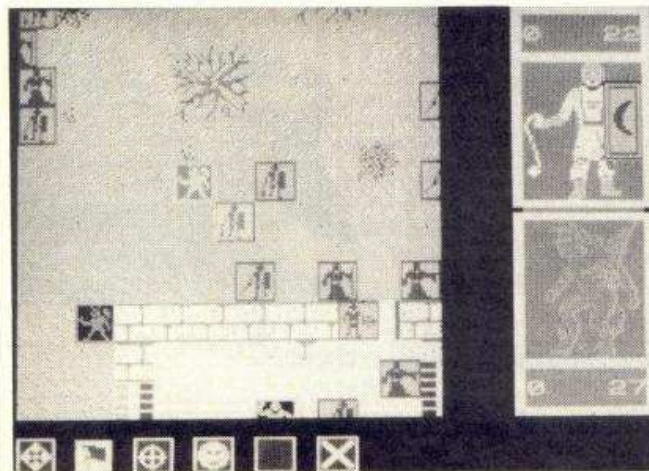

The icons represent all the kinds of wizard and warriors you can choose to make up your force. However, different types of troops have different costs. Basically, you can have a large, poorly equipped

outfit or a small, powerful one. Fortunately, all character stats are given in the rules. The last choice may be deleted or the combat mode may be entered. In this

mode the icons are Movement, Home, Long Range Combat, End Turn, Blank and Quit. A joystick or keyboard option allows pointer movement.

Combat includes, zones of con-

trol for enemy characters, ranged combat with fireballs (two types) and longbows, movement cost and cover factors for different terrain types. The game format then, is essentially simple.

The only scenario available to 48K users is *The Village* which involves the Guard in a trap set by the enemy monsters in a deserted village. *The Forest* deals with another group of Guards fending off monsters intent on sacrificing them. Finally *The Inn* is a strategically important building for both parties which can be fought over the last scenario. The idea of not having the scenarios as sequential pieces but as aspects of a wider battle is very appealing. In all cases, the player has to defeat the Fire Demon to win whereas the monsters have to entirely obliterate the Guard to win. Consequently, battles are a hard fought affair.

There's nothing particularly innovative or clever about this game. It simply plays well. The presentation could have been higher, the background more atmospherically worked out . . . a little more imagination generally. It gave the impression of a game given a fantasy front to grudgingly please audiences demanding a

wider taste, but with little real care for the genre. Nevertheless, there were no moans considering the price. £7.95 is extremely attractive

for any game now, and considering the benefits for 128K owners, this one has to be worth it.

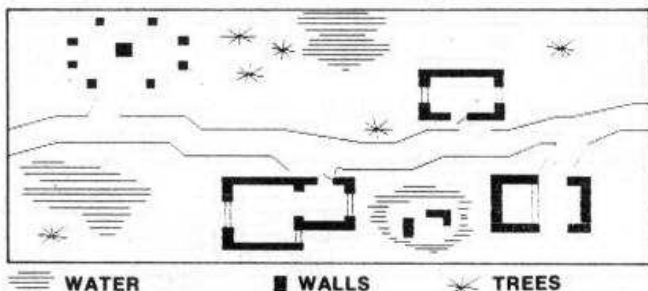

The map from The Village scenario. You're trapped in the middle and the monsters are coming at you from all sides, eek!

PRESENTATION 69%

Neat but sparse
RULES 67%

Simple but effective
PLAYABILITY 81%

The control system leads to satisfying and rapid play

GRAPHICS 65%

Nothing to write home about but distinctive and suitable

AUTHENTICITY 64%

Not this game's strong point

OPPONENT 79%

Can get vicious

VALUE FOR MONEY 82%

128K owners especially should feel the value

OVERALL 77%

A fair product. Interesting and unpretentious

became a microcosm of the war on the western front before fizzling out altogether.

So to the game, which comes in a double cassette box, has glossy instructions including screen map and historical notes — and, of course, a cassette. This carries the main 48K game on one side and an expanded version of the game for 128K owners. Let's get one thing straight. Wargaming has always suffered on the Spectrum because of a lack of disk drives. However, as 128K machines largely make up for this loss, it's great to see ccs taking advantage of the chance to improve the scale of their games as often as they can. Nice one.

The expanded version of the game allows tunneling to be used as an option. An interesting idea that works fairly well. The game works in traditional format and there are no surprises in store for experienced gamers. Novice players will find the step by step commands slow and a little complex at first, but should easily get into play with patience. If a complaint has to be made, the unit symbols are both obscure and a little poor. Still, a minor quibble only.

Victory conditions are difficult to achieve but their complexity and intricacy accurately reflect the missed opportunities of both sides. The game can (theoretically) cope with three players, ANZAC, British and Turkish — though a single player option is provided for control of the allies.

The game plays surprisingly well, considering the subject matter and presents a real challenge (I haven't beaten it yet). The joystick option (Kempston, Interface 2) was most welcome and the presentation coherent. There were no observable bugs but the play was a little slow.

I like the fact that ccs is diverging from the norm with their games. They deserve encouragement and success. There is a long way to go in the quality of British strategy software but ccs are approaching fresh ideas with an exciting perspective. This happens to be very much the enthusiast's game, but it is a very good example of such. The company is making more generally appealing material as well. I won't recommend this out of hand but I see no obvious flaws in terms of technical competence.

GALLIPOLI

Producer: CCS
Retail Price: £8.95
Authors: A & O Bishop

encountered, crippled the chances of any strategic simulation. Now, ccs have decided to change that with Gallipoli. An interesting idea for a game too.

Rarely has the idea of a game

The idea of the campaign was simple and well meant. If the allies

distraction of a second front, paving the way for the breakup of the costly stalemate in the trenches of France.

It went wrong. It seems that more than anything else, bad communication

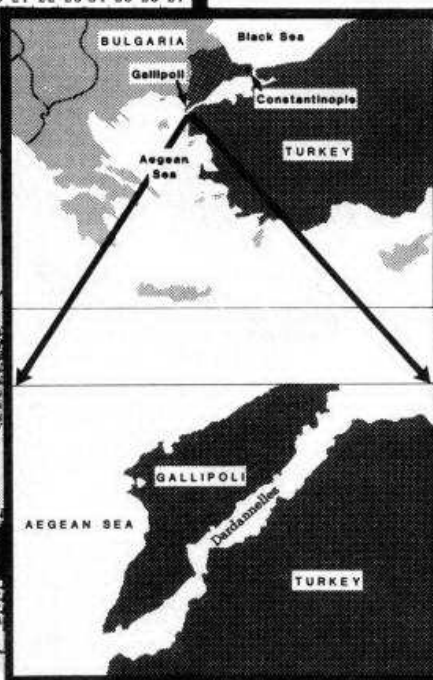
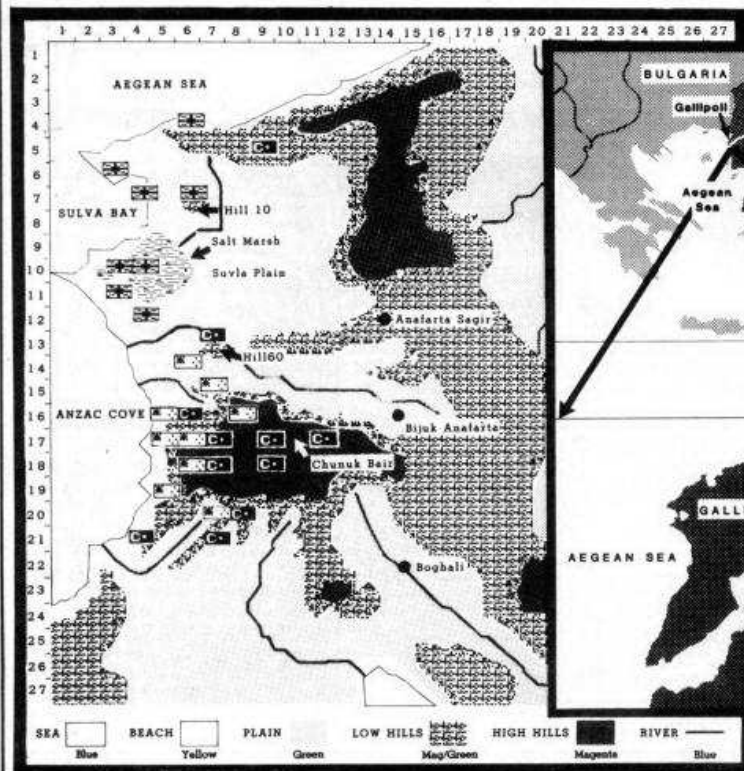

The whole of the area covered by the game and the start position of the units. The precarious position of the ANZACS can clearly be seen

based on WWI been attractive. That war, perhaps more than any other, was so full of mindless incompetence on the parts of those in command at the time that the stalemates so frequently

could send the Turks out of the Dardanelles, not only would a new supply line to Russia be opened (the sea routes were iced over for much of the year), but Germany would have the painful and tiring

was the factor that most helped put paid to the allied plans, as it had done so often before in the war. Advantages were not seized upon. Barrages ended too early and allowed Turkish gunners to remain their posts in time to mow down thousands of British, ANZAC and Gurkha troops who were being sent over the top. It just

PRESENTATION 74%

Crammed but has everything you need

RULES 80%

In depth if perhaps a little unfriendly

PLAYABILITY 78%

Not really that easy to get into but a lot goes on

GRAPHICS 74%

Poor unit symbols let the game down somewhat

AUTHENTICITY 87%

Very good

OPPONENT 89%

It Bites!

VALUE FOR MONEY 88%

The going rate for a good fight

OVERALL 87%

Limited appeal maybe, but admirably implemented

FRONTLINE



FORUM

With yet another mini-Forum, there's only room for one letter. Worth the read though . . .

DUNGEON DEFENCE

Dear Sean

I have to comment on some of your somewhat cynical comments on the state of the RPG industry and that side of gaming in general. I don't believe that the RPG industry is 'stagnant' at all. It's not the number of people at the conventions that count, or the number of

new games being released onto the market that dictate whether the industry is alive or dead. It's the number of bleary-eyed players who regularly remain awak until the early hours of the morning, enjoying stretching their imaginations and intellect to the challenge of role playing games.

Perhaps it hasn't occurred to you that the industry devoted to RPGs has reached its limits. There are

more games than anyone could hope to play. And the technical aspects of these games are so good, there is no longer a need to revise the games already on the market.

Adrian Walker, Cork, Eire

First, I must point out that room prevents me from re-iterating some of the analogies Adrian made to prove his points. The analogies were good in terms of internal consistency but bore no relevance to the argument. This was further compounded by the fact that Adrian has missed the point altogether.

Reasons. Adrian implies that the industry cannot be judged to be alive or dead by the number of new games or people attending conventions. Very true. Except that I never said the industry was either of these. I said it was 'stagnant.' And, if you hold a convention, year after year and the appreciable number of visitors does not increase — the hobby has to be stagnating.

Adrian's idea that as there are more games (of the highest quality) than anyone could hope to play, the hobby can go no further, just shows how narrow-mindedness can strangle something (sorry Adrian, you're a symptom — not the cause). Too many people

in the industry want to remake D&D and see very little scope for doing anything different. Well how about more social interaction games like How to host a Murder? Interactive drama? The exploration, in gaming terms, of the psychology of role playing? More crossover with the software industry — now hardware and software are becoming more ambitious? Eventually, there could be interactive television or more. But the groundwork for this relatively new aspect of leisure must be explored now and in a constructive manner. Instead, the industry pundits are condemning themselves to being a minority group of such triviality and infinitesimal unimportance that millions will be lost as the whole concept slides back into oblivion.

Conventional and computer role playing games have not reached their peak. They have only just been born. The possibilities for both are incredible but they are not being realised. Two game-book authors I know were approached by Scotland Yard to design a training manual based on their game system! Now if that isn't an innovative application of a concept, I don't know what is. Sorry, Adrian but I think you're totally mistaken. I wasn't trying to compare anything. There was only a statement.

SMG

In future, don't forget to write care of Philippa! The address is FRONTLINE FORUM, PO Box 10, Ludlow, Shropshire, SY8 1DB. Cheers.



WAR GAMES



Fast, interactive with a scrolling map and hidden movement, over a varied terrain. For 1, 2 or 3 players.

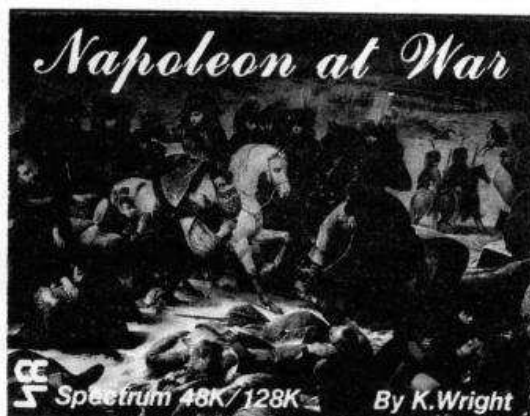

High degree of computer intelligence allows this game to be played at strategic and tactical levels over a scrolling map. 1 player game.

Price £8.95 each. Available Mail Order — 48hr. delivery — from

Cases Computer Simulations Ltd., 14 Langton Way, London SE3 7TL.

Strategy Games.

They're no pushover.

DR. WHAT

Producer: CRL
Retail Price: £7.95
Author: A.K Fox

Four foolish timelords, doctors, What, When, Where and Why are getting themselves into a bit of a scrape. They got together for a reunion party; large amounts of Neuro Cardinal Cocktails were consumed but getting home after that party wasn't something any of them had actually considered.

Thus the four Doctors find themselves stuck in four different locations with thumping great hangovers and very hostile environments to contend with. The four doctors must take a trip and visit the Jelly Baby of Infinite Wisdom and Ultimate Knowledge who lives in the tower of Darabur, a place nearly as remote as Crash towers. In order to get to this guru Jelly Baby each Doctor must be transported via the Trydis to a certain location. From there all four doctors must make their way to the tower of Darabur for the ultimate confrontation.

Each of the four doctors is stuck in a different location. Doctor Why is stuck in What's laboratory. Dr What is stuck under a sheer cliff face which seems totally impossible to climb. Doctor When is lost in a hostile forest full of horrible beings and Where is being hassled by some very nasty Daleks. The general idea is to extricate each doctor from his nasty predicament and get him into his Trydis to rendezvous with the other doctors.

Various objects can be picked up along the way which are essential in order to finish the game. Each Doctor can only carry three objects at one time. These can be picked by pressing the relevant key and dropped and used at any

time during the game. Some of the objects will disable a nasty such as the baseball cap which, when thrown will slip over the marauding Dalek's head and stop it from moving.

Each Doctor has a certain amount of energy, which is represented by a magenta jelly baby on the bottom right hand corner of

of the Doctor's should die in this way then it will be impossible to finish the game.

Control of the Doctors can be changed by pressing keys one through to four. The Doctor you are currently controlling is shown at the bottom right hand corner of the screen. The middle section shows what objects are being held by the Doctor you're controlling.

The game ends when all four Doctors are at the Jelly Baby of Infinite wisdom. It will now tell you your IQ depending on how you managed to get that far in the game.

started to play this rubbish. Dr. What is obviously, from the packaging, suppose to be a rip off of the BBC's Dr. Who, and a very dismal effort it is. The graphics are average, sound is practically non-existent, and playability is kept to a minimum. I shouldn't think many people would go wild over Dr. What—that is if CRL don't get sued first."

● "It's been a long hard month. Just as I thought I was getting to the end of it with my sanity intact, this comes along. CRL really don't do themselves any favours by

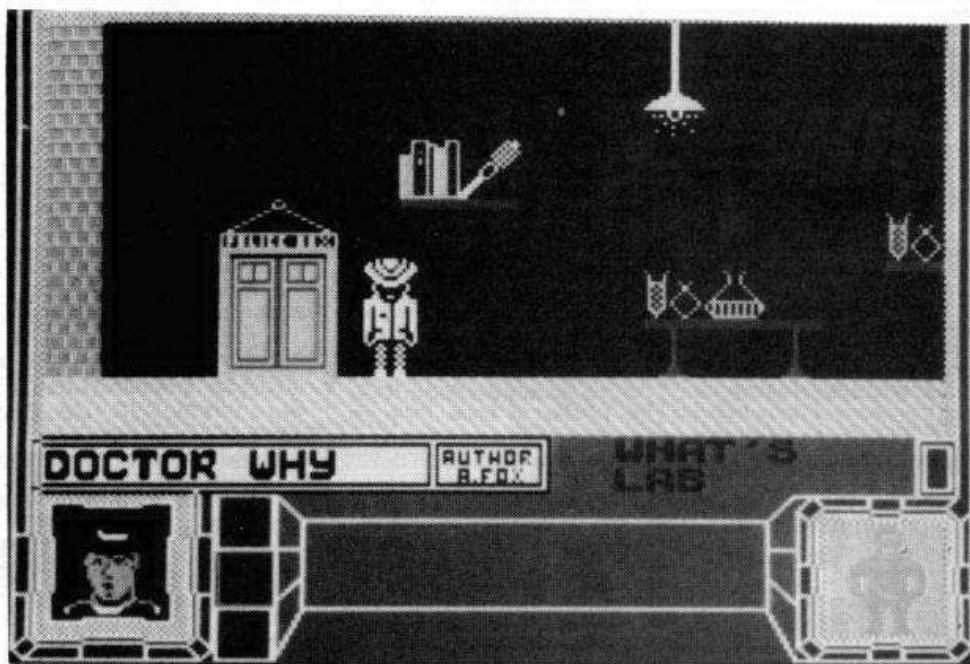

Dr Why finds himself in the lab - but what objects are going to be useful?

the screen. This energy is lost every time the doctor collides with any of the monsters in the game and this is shown by the jelly baby gradually being eaten away. If one

CRITICISM

● "Dr What would probably be a lot easier to play and a lot more appealing if the instructions told you something about the game? After a sly chat to the people at CRL (which didn't really make anything clearer) I was just about to admit defeat when low and behold for no reason apparent I managed to transport myself, gosh! Could I do it again, you must be joking. The graphics are below average for this type of game, there is lots of colour clash and the characters move badly. The sound is dire, there are no tunes and virtually no spot effects during the game. On the whole this is an unpleasant game to play so I wouldn't recommend it."

● "WHAT the hell is this? WHEN can I pull the plug out, please? WHERE does it go? and, WHY the hell release it? Just a few of the questions I asked myself when I

releasing this sort of thing. The aardvark fan is a hard man to please, and I somehow don't think this is going to come up to the mark. Instructions are minimal, graphics are dull and generally I can think of no good reason to buy this even if it was on CRL's budget label."

COMMENTS

Control keys: definable
Joystick: any
Keyboard play: responsive
Use of colour: nasty, garish with lots of clashes
Graphics: naff
Sound: boring spot effects
Skill levels: one
Screens: approximately 40 to 50
General rating: a nasty steaming dollop of What.

Use of computer	41%
Graphics	38%
Playability	28%
Getting started	16%
Addictive qualities	19%
Value for money	12%
Overall	17%

Where finds himself in a tricky spot with a Dalek



Spectrum 48K (& 128 compatible). Commodore 64/128 & Amstrad 464/6128.

NOW ON SPECTRUM!



"A first-class debut. Arcade fans should snap it up" – **PCW**. "There's one hell of a lot in **Nexus**.

It has arcade action, codes to be cracked, a large complex
to find your way around, and intelligent enemies too" – **Commodore User**.

Nexus is available from good software retailers nationwide. Price **£9.95** on Cassette, **£12.95** on CBM disk,
£14.95 on Amstrad disk. Mail order from: Nexus Productions Ltd., DSB House, 30 High Street, BECKENHAM,
Kent BR2 1AY. Cheques only payable to Nexus Productions Ltd.

If you're already elite . . .
 there can only be
 one more challenge.



ADVERTISING?
 TODAY IT'S NO LONGER THE
HARD SELL . . .

WITH TODAY'S CONSUMERS, WE'RE IN THE COMMUNICATION BUSINESS.

THE COPYWRITER'S ROLE IS TO INFORM.
Strutt, Wholk, Pozer, Souse
Incorporated Practitioners in Advertising

Oily
 I've pinpointed key brand advantages, stressing the leisure management strengths of Mosaic's new product offerings.

AND THE ART DIRECTOR SEEKS TO APPEND COGENT VISUAL SUPPORT

The Archers
 In *The Archers* - The Computer Game you're the script editor on BBC Radio 4's long-running serial. Your decisions affect life in Ambridge - and your listening figures - watch out for memos from Controller Radio 4! A clever and amusing illustrated text game by the utterly brilliant Level 9 team.

Twice Shy
 Based on the best-selling Dick Francis thriller, this illustrated text adventure plunges you into the seamy side of the horse-racing world. The RamJam Corporation (ingenious things!) have written two games for the price of one: the racing simulation can be played independently and as a vital part of the adventure itself.

Col
 I'm having creative block this week. Use the packshot - it's got horses on it.

**DICK FRANCIS
 DICK FRANCIS
 TWICE SHY**
 PROGRAM BY THE RAMJAM CORPORATION

WE MUST MAKE THE CONSUMER AN ALLY, NOT A TARGET

Col
 Why don't we shoot Eddie Grundy and Jack Woolley feeding a blow-up packshot to some sheep? Don't forget the Beeb wants us to say. By arrangement with the BBC somewhere.

MEMO
 SO PLEASE BUY THE ARCHERS LISTENERS
 and put your money on the favourite, Twice Shy

MOSAIC PUBLISHING

THE ARCHERS Witty, entertaining and programmed by Level 9.

TWICE SHY Dangerous action adventure - a new RamJam classic.

Available for Spectrum, Commodore and Amstrad (The Archers also for Atari and MSX).
 Cassettes £9.95. Disk versions coming soon.

Distributed nationwide by WMS Distributors, St John's House, East Street, Leicester LE1 6NE (0533 551190) to stores of class and distinction and all the good stuff.

YOUR MISSION - RETRIEVE PK430 YOUR COUNTRIES
 REVOLUTIONARY FIGHTER..... LOCATION - 400 MILES
 BEHIND ENEMY LINES..... POSSIBLE ENEMY
 ARMAMENTS - FLAME THROWERS, HELICOPTERS,
 TANKS, JEEPS, LANDMINES..... YOUR EQUIPMENT -
 THE WORLD'S MOST SOPHISTICATED ARMED VEHICLE
 ENEMY STRONGHOLDS - PRAIRIES, CITIES,
 MOUNTAINS, AIRFIELDS, BRIDGES..... MISSION STATUS -
 VITAL..... MISSION CONSEQUENCES - WORLD PEACE.....
 MISSION OBJECTIVES - YOU MUST.....



MOUNTAIN



BRIDGE

CBM64

£9:99

TAPE

£14:99

DISK

SPECTRUM 48K

£8:99

TAPE

THE ARCADE SMASH
 HIT FROM



DATA EAST

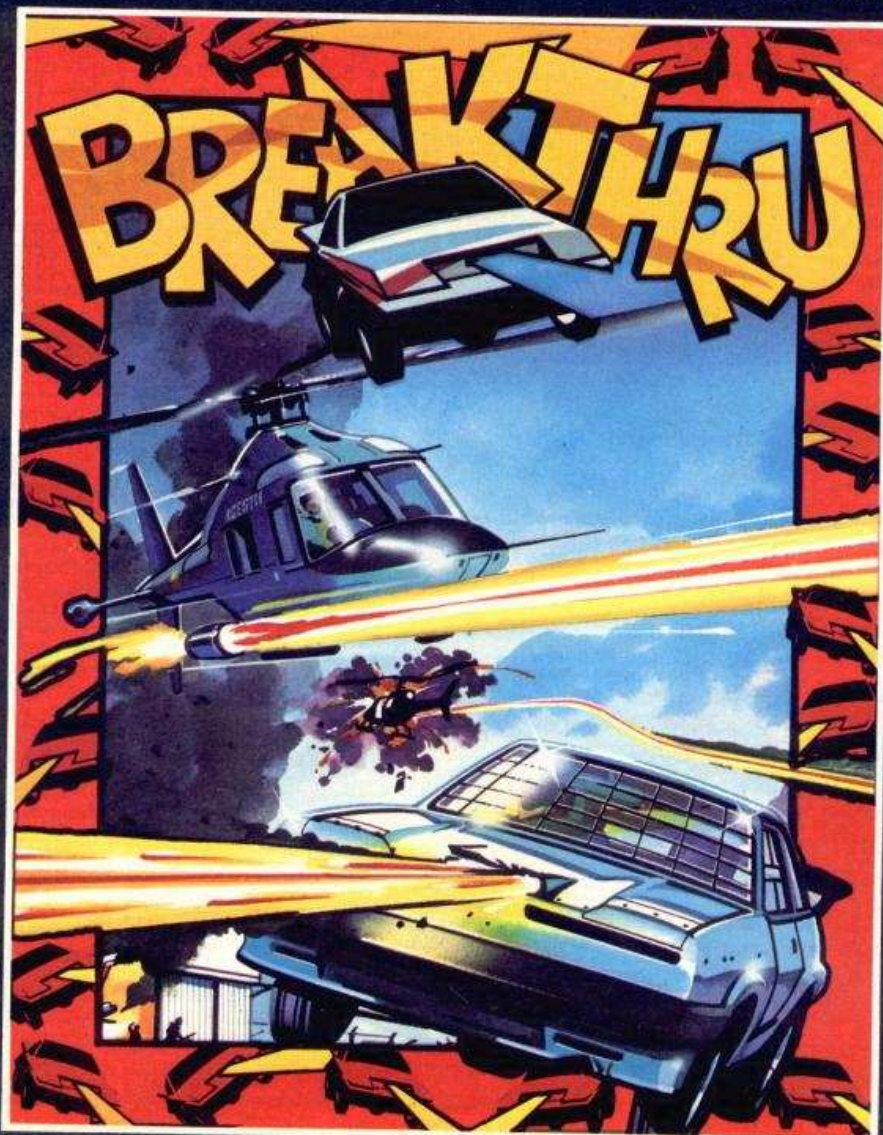

PRAIRIE



CITY

AMSTRAD

£9:99

TAPE

£14:99

DISK

U.S. Gold Ltd.,
 Units 2/3 Holford Way,
 Holford,
 Birmingham B6 7AX.
 Tel: 021 356 3388.

SCREEN SHOTS FROM
 ORIGINAL COIN-OP



MAILSTROM

Producer: Ocean
Retail Price: £7.95
Author: Reptile Industries

Michael starts out his days work with a conventional post van. However, such is the line of his work and the ferociousness of the locals, that he will need to upgrade it quite considerably.

Before Michael can get anywhere in the game he must collect various items from the post boxes along the way. He doesn't have any keys so he must use his initiative to get them open. The odd bomb found in the road will blast an adequate hole in them, but these are few and far between. Amongst the goodies found in the post boxes there is also the equipment needed to upgrade Michael's van. Anti-personnel rockets will make short work of any post box until he can find the skeleton keys, these can also hassle the locals. There is a super pursuit mode which turns the post van into something totally different so that it will speed along at a fair old rate.

The objective of the game is to exchange postal sacks for letters to be delivered. When Michael visits the sorting Depot, house numbers will light up at the bottom of the screen. The number of these houses will depend on how many postal sacks Michael has deposited in the 'In' shute at the sorting office. Michael must then visit

each house indicated to deliver the letters.

All the controls are icon driven in the game. Pressing fire when Michael is in the van or standing very close to it will get him into the menu. Michael can move the cursor over the required option and this will activate it. Michael starts the game with very few options on this menu, but as he picks up various objects the options increase.

The inhabitants of this town are very aggressive characters and will try their utmost to hassle Michael when he's trying to carry out his job. When Michael gets hassled by one of these people he will sustain damage which can be checked by looking at the first aid icon. If Michael's damage gets too high then S.K.I.T may suggest a quick visit to the hospital. These nasty characters in the game can be killed by running them over in the van. However, if an innocent citizen gets killed then points are deducted and Michael is arrested by the local policeman. If Michael gets arrested too often, or if he runs over a policeman, then the game is over.

CRITICISM

● "First impressions of the awful graphics, were with me right the way through my playing session of *Mailstrom*. I must say that it ruined my admiration for

Postman Nasty hares away from the sorting office in super pursuit mode

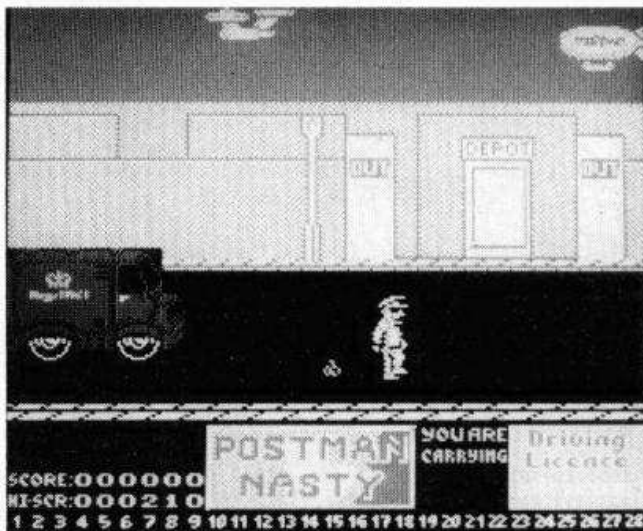
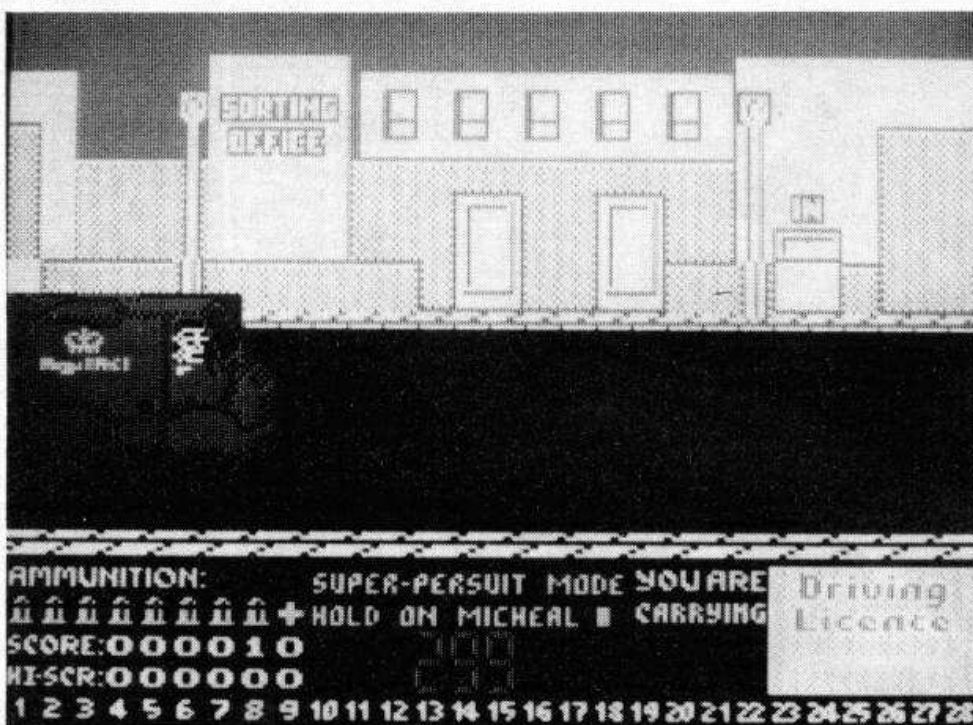

delivery to the depot, all in a days work to your average axe wielding homicide postman

Postman Pat, upholder of the peace, and generally right do-er. The game's main high is the ideas incorporated in it, but I think that the implementation is sorely lacking. Maybe the programmer of this could get together with Jonathon Smith, or someone with similar talent, and then maybe we would see a game really worth worth playing; how about it Ocean?

● "This game really appeals to me, this is mainly due to the sick sense of humour of the programmers. The gameplay isn't really very slick but if you stick with it *Mailstrom* will grow on you,

although I can't really see myself playing it for very long. The graphics are fair, the characters are nicely animated but not well drawn and the street is well detailed but it scrolls badly. I can't really recommend this one, for eight quid you should get a game that will keep you occupied for more than an afternoon."

● "My, What a strange game this is. And to see OCEAN publishing it is twice the surprise. *Mailstrom* is a very simple game to get into but has nothing to keep any self-respecting game player attached for any length of time. The way the game is presented is quite good, with a redesigned character set and a nice screen layout. The graphics are small and rather dull. A very basic game at a high price."

COMMENTS

Control keys: Up=Keys Q to P on the second row, Down=keys A to ENTER on the third row, Left=CAPS SHIFT and alternate keys on the bottom row, Right=Z and alternate keys on the bottom row, Fire=Keys 1 to 0 on the top row
Joystick: Kempston
Keyboard play: responsive
Use of colour: unimaginative
Graphics: rather slow
Sound: spot effects
Skill levels: one
Screens: scrolling play area
General rating: a bit of a laugh

Use of computer	62%
Graphics	58%
Playability	58%
Getting started	64%
Addictive qualities	56%
Value for money	54%
Overall	59%

ROOM 10

Producer: CRL
Retail Price: £7.95
Author: Pete Cooke and Chris Newcombe

Life on distant colonies and outposts can be pretty dull. The Galcorp Leisure Corporation provides leisure activities for these desolate outposts and bases many of the games around the special low gravity conditions found on the far asteroids and outposts. One of the more popular games devised by the Galcorp Leisure Corporation is low gravity Glyding. Played in a large room, two players compete against each other. Each player controls a large 'bat' and the aim is to stop the ball from hitting your back wall, while at the same time trying to hit the ball onto the other players rear wall. The bat is against the player's wall and covers roughly a tenth of the area.

Play begins with player one taking a service. Play continues with the ball to-ing and fro-ing between the two players until the ball strikes the wall behind one of the competitors. When this happens the opponent scores five points and the losing player restarts the game with a service. Play continues in this mode until thirty-five points are reached and the first

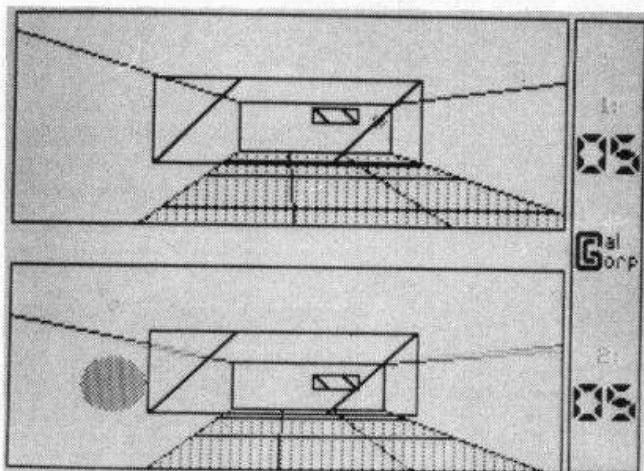

Player two concedes five points after a mean shot that bounced deceptively

led by the keys or joystick and can be manoeuvred upwards, downwards and from side to side. Pressing fire serves the ball to start, although your bat must be covering the ball before you serve or else you'll miss and five points will automatically be awarded to your competitor. The screen is separated into two halves. The two section shows the court as seen from each player's vantage point looking down to the opposite wall. The score is shown to the right of the

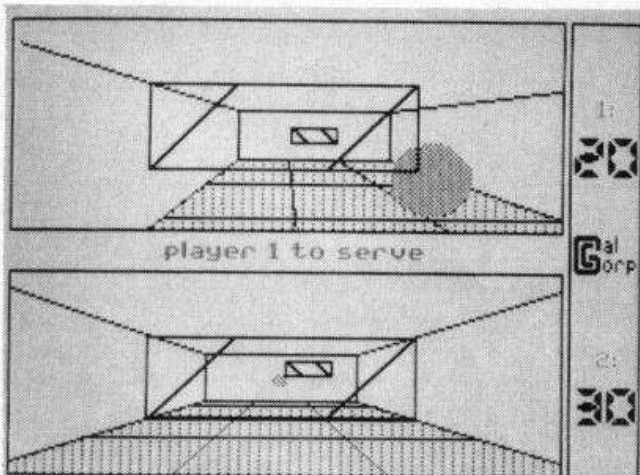

Match point. Can player one save the game; he lines up a mean serve

person to reach this gets to be the winner.

There are varying levels of difficulty in the game ranging from slow or adagio as it's described in the menu to pretty fast or vivace. You can also alter the computer's skill from low to high. There is a two player option to enable you to compete against a human partner rather than the computer.

The screen is yellow monochrome although the colour can be altered if you fancy a change of background. The 'bat' is control-

led by the keys or joystick and can be manoeuvred upwards, downwards and from side to side. Pressing fire serves the ball to start, although your bat must be covering the ball before you serve or else you'll miss and five points will automatically be awarded to your competitor. The screen is separated into two halves. The two section shows the court as seen from each player's vantage point looking down to the opposite wall. The score is shown to the right of the

CRITICISM

● "Room Ten is a very strange game, the idea may be very simple but it is very difficult to get into. If you stick with it however the game can become fun and very competitive, especially in two player mode. My only real

● "The graphics are quite strange, and it took me quite a while to get used to all the lines that were flying about the screen. Sound is a bit on the basic side, with only a few beepy spot effects. I found the game itself very boring to play after only a few games. The speed of the game is quite slow — even on the fast speed — and not helped by the unresponsive key actions. Room Ten is not one of the most addictive games I've ever played, but I'm sure will appeal to some members of the Spectrum squad."

● "No, I'll refrain from making the VERY old joke that's now flying around the office all about Pong in a box, etc. Room 10 isn't all that bad a game. The 3D effect works well, and the game moves at a frantic pace sometimes. Playability is good, and though I don't think I could spend a lot of time playing it, it's the sort of game that I'd play when there's absolutely nothing else to do. It's not amazingly revolutionary, despite the very good way that it handles graphics, but I think that it might be worth getting hold of."

COMMENTS

Control keys: definable
Joystick: Kempston, Sinclair, Cursor
Keyboard play: responsive
Use of colour: minimal
Graphics: slowish but quite effective
Sound: a few spot effects
Skill levels: six separate speeds, three computer skill levels
Screens: one main playing screen
General rating: 'off the wall' sports game

Use of computer	59%
Graphics	63%
Playability	71%
Getting started	61%
Addictive qualities	61%
Value for money	52%
Overall	62%



nag about this one is that as with any sports simulation you can get good at it so it is easy to beat the computer, this only takes about twenty minutes of solid playing so it can become boring very quickly. The graphics are good but a little misleading at times which can have disasterous effects. The sound is fair but not exciting. I wouldn't recommend it too strongly as it can get extremely monotonous if you haven't got a friend to play with."

NEW TAPE UTILITY 9

This program gives a tape back-up of most software! Even converts most jerky loaders to normal for reliable loading. Manages v. long programs (even 51k!), fast loaders, etc, etc. 48k Spectrums only. £6.99 on tape (£4.99 if updating).

NEW TRANSFER PACK 3 — for tape to drive

A software system to convert many TAPE based programs to your DRIVE (no matter what type) + OTHER USEFUL utilities. Most jerky loaders are EASILY converted to drive. Pack has at least 7 programs! Only 48k Spectrums. Opus/Beta owners add £1 for optional extra program. State name of your drive when ordering. £11.99 on tape OR £12.99 on m/drive cartridge. (£6 if updating)

INFORMATION SHEETS — £1 each — approx 8 transfers of popular programs, per sheet — needs TP3. Up to No. 25 available. Special offer — No's 1 to 20 only £4.50!

MICROTRANS — for m/drive to m/drive back-up + tape to m/drive (incl headerless) — does NOT convert programs. £3 on tape, £4 on m/drive cartridge

Overseas: add £1 Europe, £2 others each product. SAE for enquiries.
ALL OUR PROGRAMS CARRY OUR MONEY BACK GUARANTEE
 (not updates)
 LERM, DEPT CR, 11 BEACONSFIELD CLOSE, WHITLEY BAY, NE25 9JW. (Tel 091 2533615)

A CONSTELLATION OF SENSATIONAL GAME COMPILATIONS

From one of the UK's leading software creators comes the finest collection of game compilations. From the finest software houses.



Gremlin Graphics
Bubble Bus Software
Gargoyle Games
Alligata Software
U.S. Gold
Ultimate

Monty on the Run
Sweevo's World
Boulder
Starquake

Monty on the Run
Sweevo's World
Boulder
Starquake



CRASH SMASHES

Peel the horizon, eyes peeled, for the most amazing collection of characters and events - an earth bound catastrophe from out of space; high flying, fast moving, bouncing balls; a furtive furry mammal dodging the law and a robot out of control and out of his mind. Excitement, fun, game appeal.... it's got the lot.

AMTIX ACCOLADES

Watch out for the invasion not just from space but the aerial bombardment of a bouncing ball as you grapple with the antics of a comic roboid and underworld supermote frantically on the run.



got the lot.

Tape

£9.95

Sword of Destiny
Jetbrix
Gullwing Falcon
Reach for the Sky

Disk

£14.95

C16 CLASSICS III

A unique opportunity to enter into combat as fought through the ages – hand to hand combat with muscle and sword; the aerial skill of World War II flying; precision and control of jetpac and handlazer and the thrilling excitement and power of 21st century spacefighter. If you like a challenge these contrasting gameplays will put you to the test.

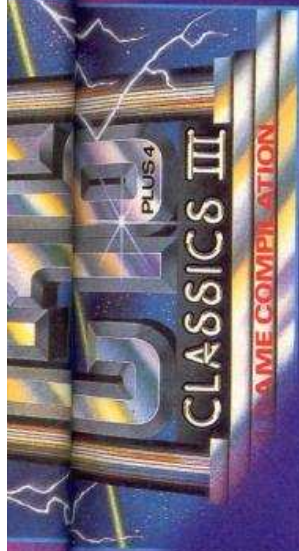

ZZAP SIZZLERS II

Colourful encounters of the extraordinary kind. Enjoy a futuristic shoot 'em up in sci-fi terrains or mysterious star systems. Go on the run with a furry little mammal or find yourself "jump sick" with an effervescent ball.

Monty on the Run
Bounder
Starquake

Grog's Revenge
Gunflight
Valkyr
Bounder



MSX CLASSICS

From stone age man to 21st century space hero, with brief stop-overs in the lawless West and 1980's to master the antics of an irrepressible bouncing ball, this rivetting compilation provides power packed excitement that transcends time.

STAR GAMES

Light years ahead for Compilations

Star Games, Alpha House, 10 Carver Street, Sheffield. S1 4FS. Tel: (0742) 753423.





SOFTWARE BY MAIL



IT'S COOL, MATE!

Retailers don't always have everything in stock you might want, but if it's within our power to get it for you, then we will. ANY of the software reviewed in this OR ANY issue of CRASH can be ordered by using the form below.

But to avoid disappointment, please ring first to check availability of unusual items!

CRASH Mail Order is backed by the resources of Newsfield Ltd, publishers of this magazine, ZZAP! 64 and AMTIX, which has been supplying more than 150,000 computer users with software for over 2 years, so you can be sure of the very best in service.

There is no mail order catalogue involved, just use the prices quoted in the reviews in CRASH or the know retail price. Should you have any queries on prices, just ring the number shown on the form and our staff will advise you.

DISCOUNTS GALORE!

Anyone may take advantage of the discount coupons on the form — £1 off orders worth more than £20, and 50p off orders worth more than £10.

Additionally, CRASH Subscribers are automatically entitled to further discounts on every item ordered. We make no charges for post and packing (within the UK)

Nothing could be simpler — fill in the form today and order whatever you like.

Order What You Want from the Largest Range of Software You Could Ever Wish For!



Name

Subscriber No (if applicable)

Address

Postcode

CRASH MAIL ORDER FORM

Telephone Ludlow (0584) 5620

Please send me the following items: BLOCK CAPITALS please!

Please note: some software reviewed may not be available until its release date. If you are in any doubt about availability, please ring first. We cannot be held responsible for delays resulting from late or non-release of titles when reviewed or previewed before their official release dates were known.

Title	Software House	Amount

SPECIAL DISCOUNTS

£1 OFF ANY ORDER WORTH MORE THAN £20

50P OFF ANY ORDER WORTH MORE THAN £10

Sorry — only ONE voucher per order!

All prices are as quoted under review headings or known retail prices and include VAT. CRASH makes no charge for post and packing inside the UK. Customers in Continental Europe should add the equivalent of 70p per item ordered. Outside Europe, please write first so that we may advise on postage rates.

Please make cheques or postal orders payable to **NEWSFIELD LTD**. Please do not send any coinage.

Sub Total: £

Less Discount: £

Total enclosed: £

CRASH MAIL ORDER, PO BOX 10, LUDLOW, SHROPSHIRE SY8 1DB

Please do NOT enclose this form/payment with any other correspondence to CRASH Magazine editorial, as it will only delay processing your order and may result in loss.

KAT TRAP

PLANET
OF THE CAT-MEN

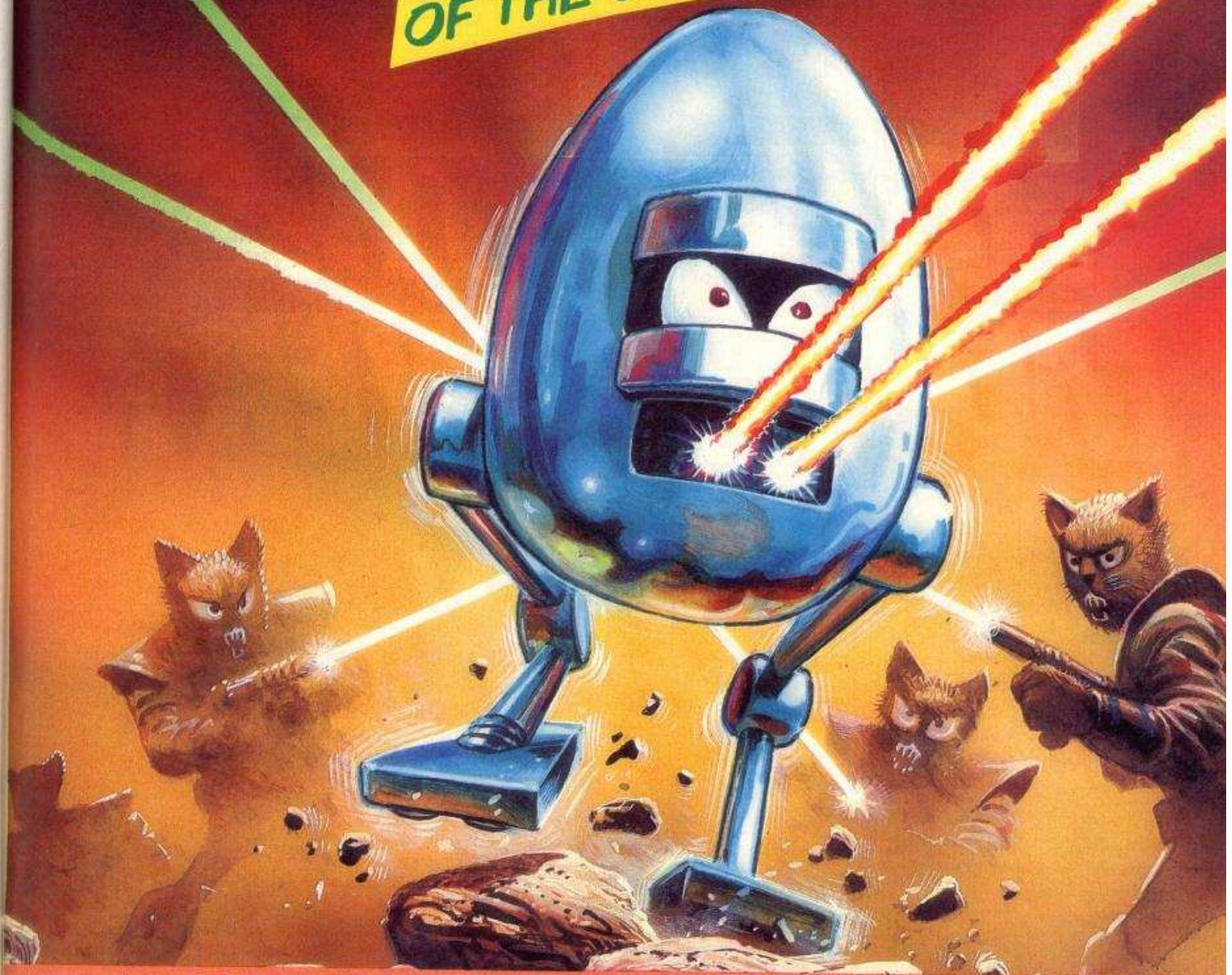

Kat Trap is the winner of the "Crash Magazine" 'Genesis' competition. This game was selected out of 4000 entries and has been programmed by the top rated Design Design team, (need we say more).

Streetwise

Spectrum 48/128
Amstrad CPC

£8.95

Programmed by

Design Design

STREETWISE SOFTWARE IS A DOMARK LTD LABEL
204 WORPLE ROAD, SW20, LONDON 01-947 5626

KONIX

SPEEDKING

VROOM!
CAN YOU
HANDLE THIS
MUCH POWER?
POW!
BLAT!

The **KONIX SPEEDKING** packs more punch. That's why it's fast overtaking ordinary joysticks to become one of the world's most popular hand control.

As it's name suggests it's built for fast handling to give you lightening fast control. Micro switches await your slightest movement, and fly into action - ZAP, POW, SPLAT, BLAM - giving you instant reactions to every command. Tough, rugged and made in Britain to the very

ZAP!

highest standards, the **KONIX SPEEDKING** comes with a twelve month guarantee.

Available for:- Spectrum and Spectrum Plus, Commodore 64, 128 Vic20. All Atari Computers, Electron, M.S.X. Computers, Amstrad and Oric at **£12.99**.

Also:- BBC, Commodore C16, Plus 4, and Dragon at **£14.99**.

Trade and export enquiries contact Wayne or Sandra on **049525 5913**.



Please send me _____ Speedkings at **£12.99** each.
_____ Speedkings at **£14.99** each

(Price includes postage and packing in the U.K. Overseas orders please send **£2.50** per Speedking.)

Computer make and model _____

I enclose a Cheque/Postal Order for _____ made payable to **KONIX**.

Please charge my Access/Visa No. _____
Card holders can telephone on **049525 5913**.

Signature _____

Name _____

Address _____

Postcode _____ Telephone _____

Send to **Konix Computer Products, Unit 13, Sirhowy Hill Industrial Estate, Tredegar, Gwent NP2 4QZ, U.K.**

FROST BYTE

Producer: Mikro-Gen
Retail Price: £8.95
Author: Chris Hinsley

The planet Cosmica is not a good place to be if you're a Kreezer. Monsters are taking over the place, and with you being a little bendy thing about six inches high, coping with huge great monsters is going to be a bit of a handful.

Unfortunately, as well as being bendy, you are also rather tasty, so the hideous monsters who have taken over the place imprisoned you in their underground ice caverns (which look about as bleak as Ludlow on a December morning). In due course the head monster chef is going to take you to the kitchen and turn you into Kreezer-a-la-fricassee.

But, at least the good news, you've managed to pick the lock and you're free! Now the tricky bit. You've got to escape from the depths of the ice caverns and rescue your mates. They're also on the menu, so you'd better let them out before they get popped in the pan.

The game is a flip-screen, two dimensional arcade adventure featuring Hickey the Kreezer. (Mikro-Gen seem to have a penchant right now for heroes ending in -ickey, look out for Mickey the Molecule and Lickey the Lollipop!) Hickey has to make his way

around the caverns avoiding all sorts of meanies. Fortunately most of the meanies seem oblivious to Hickey's presence and follow set patterns. All the same, Hickey has his work cut out to survive...

The controls are left, right, jump and fire. Moving left or right makes Hickey bend over until his head touches the ground, and then his head attaches to the ground while his legs go over his head. Actually, it's very difficult to tell his head from his legs — he moves in a squodgy sort of way, rather like those Slinky springs you used to be able to buy. He can only leap straight up, but he can squodge along when he's on the way down. Apart from the meanies, the cave also contains ledges to help him, spring platforms that allow super jumps and mattresses that cushion very long falls.

The hero can blast the nasties and ammo is left lying around in plentiful supply in case he runs out. To use an item, it must first be picked up (which causes it to appear in a window to the left of the status area) and then used by prodding the USE key. Using an object cancels the effect of the object currently in use, so it might be necessary to pick up an object, but not actually use it until it's needed a little bit later on.

Three varieties of sweetie can be found in the caverns and they form a critical part of the game: sweets are red, green or blue. Red

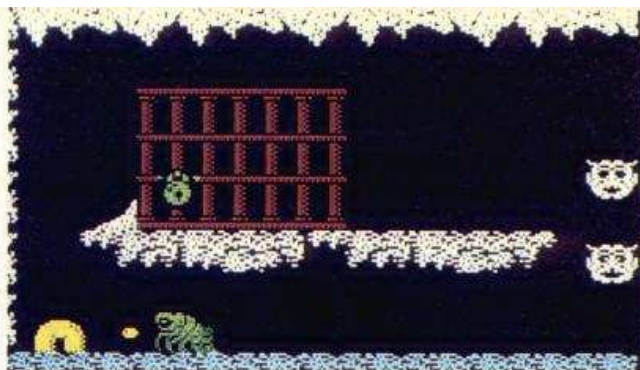

The hero has just escaped from captivity — now it's on to save his chums before the end up on the monsters menu...

sweets allow you to squodge faster, thus zipping under some rather nasty meanies. Blue sweets allow you to leap higher — vital in order to get on to some screens. Green sweeties allow you to fall further without helping the nasty monster chef by turning Hickey into an oven-ready Kreezer pancake.

Contact with the horrid hungry monsters often spells instant death and the loss of one of the five lives supplied. Death also comes to Hickey if he fails to rescue the Kreezer imprisoned on the current level before the Twang meter at the bottom of the status area reaches zero.

CRITICISM

“Getting into this game wasn't as easy as it should have been — the instructions don't set the scene very well and it is very difficult to get anywhere on your first couple of goes because the nasties are particularly vicious. After that the game becomes a little easier and a lot more playable. Hickey has to be the most endearing computer character since Berk from Trapdoor what style, what animation, what a cute end-over-end walk! The graphics are, on the whole, good and the scenery is quite

obnoxious. There are many different types of caverns, and the characters are very well animated. The sound too is good with a nice tune on the title screen and extensive use of spot effects. I really enjoyed playing Frost Byte and recommend it.”

“I really enjoyed my first few games of Frost Byte but after a few games I soon realised that it was a colourful pattern game — once you've done it, then there is no problem doing it again, which didn't make me want to go to the trouble of loading it up for another session. The graphics are very well drawn and extremely colourful, but are let down by some very bad collision detection. The game features some very smooth animation of the main character, but the other characters move in a very inferior fashion. I'm sure that people who like this type of game might get into it, but I found it very boring after the initial attractions.”

“I like this game: it has got good graphics, nice sound, and loads of fun elements — everything about it is done to a reasonable standard. Though it's not the sort of game that I could play for the rest of my humble existence, I feel that it has a great deal of appeal. The graphics are aggressive-looking or cute, according to the atmospheric requirement, and the playability, of which it has reams and reams, makes it very addictive. Very good value for money — congrats, MIKRO-GEN.”

COMMENTS

Control keys: redefinable: left, right, jump, use, fire
Joystick: Kempston, Cursor, Interface 2
Keyboard play: responsive and simple
Use of colour: colourful and effective
Graphics: some detailed characters, jolly backdrops
Sound: average for this sort of game
Skill levels: one
Screens: 50
General rating: A small spring forward for arcade adventures.

Use of computer	85%
Graphics	87%
Playability	86%
Getting started	85%
Addictive qualities	86%
Value for money	83%
Overall	86%

A nasty-looking green monsteroid perches on top of a Kreezer cage. Our hero is the little yellow guy all bunched up on the floor on the right — he's about to sprong into the air



Off to a flying start as tough hard guy head butts a knife-welding maniac

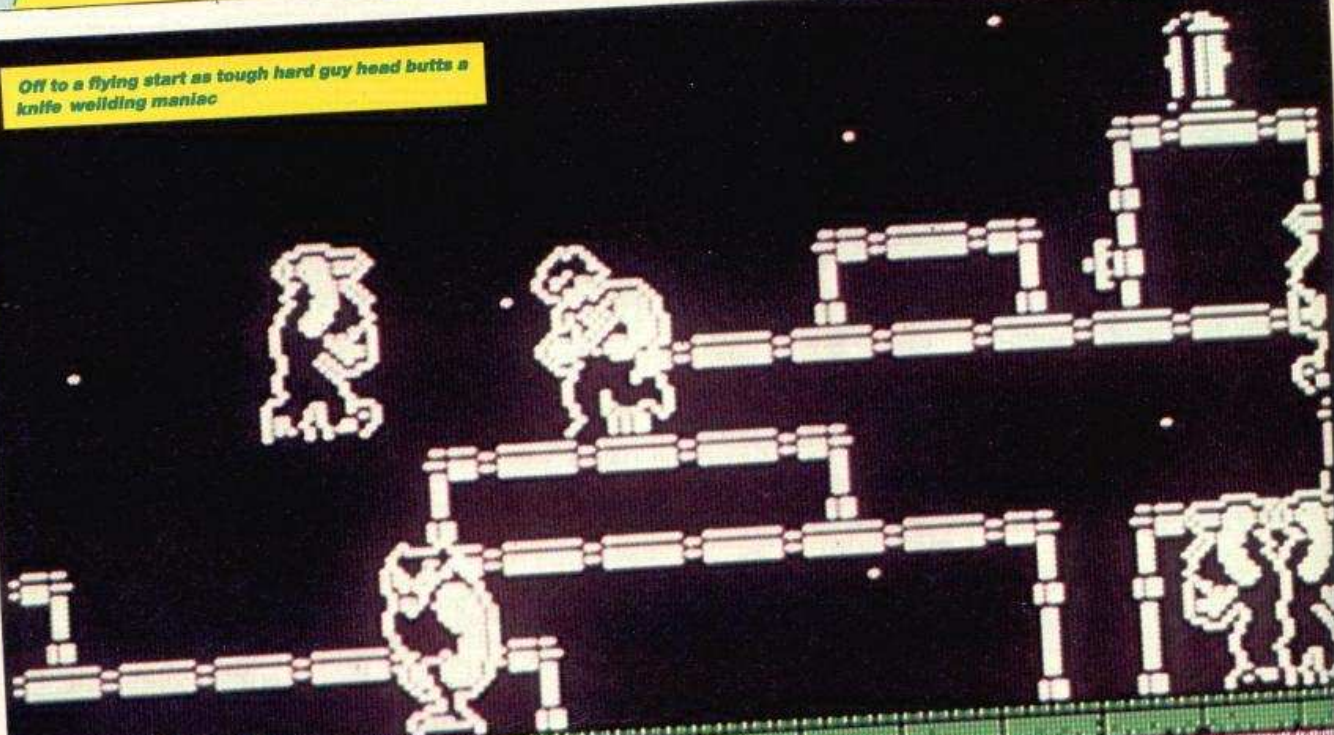

SKORE 003900



USE YOUR HEAD



Producer: Ocean
Retail Price: £7.95
Author: Johnathan Smith

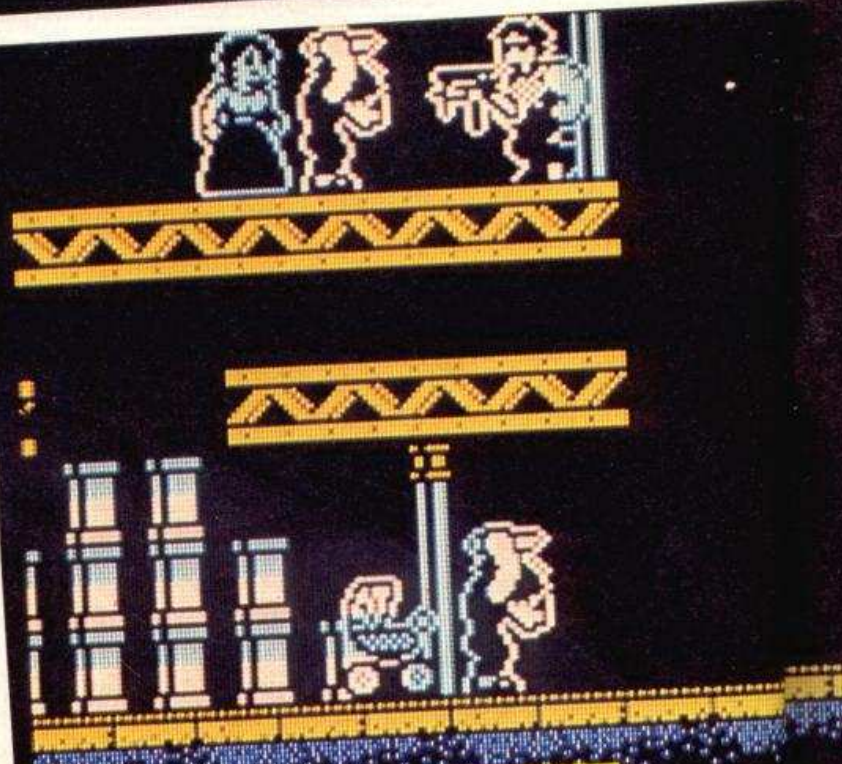

Don't push him, another knife-welding maniac is dispatched with the laser gun. He's found his girlfriend, and the disappearing duck shows how much longer he'll have his weapon

C·O·B·R·A

A
CRASH
Smash

Ocean's latest *Game of the Film* release follows the psychotic adventures of big tough guy Cobra, played in the movie by Sylvester Stallone. Top model Ingrid Knutsen (very probably Brigitte Neilson) is getting some serious hassle from a band of mean and dirty killers, who are set on capturing her for themselves and doing horrible things to her before handing the poor girl over to the evil Night Slasher (eek). Your job as the Cobra is to ensure her safety and kill the opposition before they kill you.

The nasties in the game are not exclusively male. Large women with bazookas hem in our hero and fire their artillery at him from all angles. Huge hunking men brandishing knives are out for his blood, and at the end of the final level there is the ultimate challenge for Cobra - to battle against the Night Slasher (eek). Cobra is a Real Man, and the thought of knife brandishing hunks doesn't scare him in the least. However, the mere sight of a pram hurtling towards him makes the poor man go all weak at the knees and he is momentarily stunned making it easier for the bad guys to get at him.

To begin with Cobra has no weapon and must defend himself with his nut, by head-butting everyone with such force that their little footies don't even touch the ground as they go flying off the screen.

Weapons can be found cunningly concealed inside Hamburgers. Each one of these tasty delicacies contains a specific weapon. This could be a dagger, a pistol or the ultimate in blast-everything in-sight-weapons, a laser sighted machine gun. How-

CRITICISM

"I loaded up *Cobra* with some trepidation, what would it be like? Well to put your minds at rest, I found Cobra to be a brilliant mindless 'kill everything in sight' game. The presentation is superb, and OCEAN have made full use of the film tie in; even down to defining a 'murder' key, and having colour/mono, sound/mute options. The sound is extremely well done, with lots of decent dittys and spot effects. The graphics are very well detailed and realistic, and the explosions are very well animated. The scrolling is very smooth and fast, and the characters move about very quickly. This all means that there's no time to think, you just have to head butt or murder every one you see. *Cobra* is very addictive and well worth the asking price."

ever, when Cobra has this handy device the opposition really gang up on him, seemingly making his job twice as hard, but in reality topping up those points. In some Hamburgers there is even a facility to make our Hero completely hard and untouchable. Cobra can pick a weapon up by walking into it. When he has a weapon in his possession a duck appears at the bottom of the screen. The weapon only lasts for a limited amount of time and this is shown by the duck gradually being eaten away. Once the duck has disappeared from the bottom of the screen, Cobra will have to resort to using his head again. Our hero can also lose his weapon if one of the nasty bullies walk into him, but at least he doesn't lose a life when this happens.

There are three levels to the game. The first takes place in the city at night. Using the platforms, Cobra must leap about dispatching the enemy. Once every baddie has been killed and all the hamburgers used, Cobra will automatically move on the next level. The second section of the game takes place in lovely rural countryside, but fear not, the bloodshed still goes on. If Cobra manages to get through this, then it's on to the factory floor and the confrontation with the Night Slasher (once again - eek!)

Meanwhile Ingrid is getting some serious hassle from the bad guys (and gals). In between biffing everything in sight, Cobra must somehow locate Ingrid and protect her from the ravenous hoards. Ingrid usually appears by Cobra when he has a weapon with him or is doing particularly well against the enemy (typical woman). She's a loyal sort of girl, and will stick by Cobra's side unless he inadvertently shoots her, in which case she'll scoot off pretty sharpish. Any contact with the baddies in the game will result in Cobra losing a life, unless he has his woman with him. When Ingrid is by his side and a baddy gets him, Cobra doesn't lose a life, but she disappears and he must track her down again.

CRITICISM

"Yeah, the hard guy is back and beating the insides of your your Speccy into shape. What a game, but why is Mr Macho scared of babies? All in all the game is extremely playable, it has all the good points of say *Green Beret* and *Commando* plus a lot more, although I can see myself getting a bit tired with it after a while. The graphics are truly the best that I've seen in a 'hard guy game', everything is detailed and well animated, the scrolling of the screen is superb. The sound too is second to none, there is a multitude of tunes on the title screen, during the game and, even one when the game is paused. This is in my view the best smash of the issue, we'll have to wait for a while to see a game that betters this. Go out and but it now, no self-respecting games player should be without a copy."

CRITICISM

"Though very *Green Beret*ish in style, I think that *Cobra* has a lot of points in its favour. The graphics are superb and the scrolling is very effective. Loads of colour and some very good tunes have been included. It took me a long time to actually get into *Green Beret*, and I think that that's one of the reasons why it didn't receive a Smash. That problem, I think is overcome because the similarity means that playing techniques are the same to an extent. *Cobra* is a good game; nice graphics, well used colour and a fair share of playability

Cobra has three lives to start with, but extra lives will be awarded for first 10,000 points and every 20,000 points after that. These lives are shown at the bottom of the main screen and are represented by boxing gloves. Under the boxing gloves is the score chart, points are awarded for killing the opposition and collecting weapons. In the centre of the screen is the Duckometer. This is replaced by the Cobra logo when no weapon is being held. To the far right of the screen is the weapon icon which shows the type of weapon currently being held.

COMMENTS

Control keys: definable
Joystick: Kempston, Sinclair, Cursor
Keyboard play: pretty sharp
Use of colour: wow!
Graphics: finely detailed with excellent scrolling
Sound: the best on the Spectrum for years
Skill levels: one
Screens: three levels of wrap around scrolling play area
General rating: the best
Hard Guy game there is

Use of computer	93%
Graphics	91%
Playability	94%
Getting started	90%
Addictive qualities	92%
Value for money	91%
Overall	93%

THANATOS

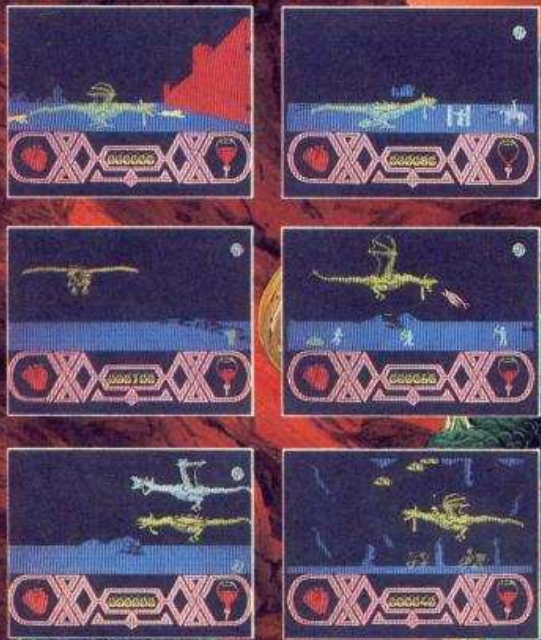

Spectrum in October, Amstrad in November, Commodore 64 in December.

All £9.95

DURELL

software getting harder

Sales dept.,
Castle Lodge, Castle Green,
Taunton, Somerset TA1 4AB
England Telephone (0823) 54489 & 5402

EAT WORM

blows a sparky

Now for something completely different. You are an insidious little WORMIE being chased through a micro-electronic labyrinth (you guessed it... a Sinclair Spectrum!) by CREEPERS in SPUTNIKS and CRAWLERS on foot (feets?). Defend yourself by shooting BURPER SPARKIES at the CRAWLERS, and BLASTER SPARKIES to take out the SPUTNIKS. You'll see the computer board in a smooth-scrolling 3D viewed from above (yawn, yawn... just another bit of mega-programming), as you crawl around in search of a DISK DRIVE on which to CLONE yourself. First you'll need to find fifty SPINDLES to eat, which will replenish your supply of SPARKIES to shoot at the BUGS. How long can you crawl down a DATA BUS? Find out how refreshing a DE-BUGGER feels when you're stuck in a Spectrum and covered in CRAWLIES. This game is like... WELL CRUCIAL MAN.

Available **October 20th**

Trade enquiries to **Centresoft**

on **021 356 3388**

Any Spectrum **£9.95**

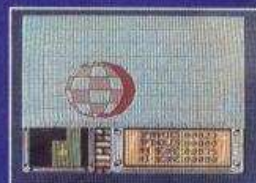
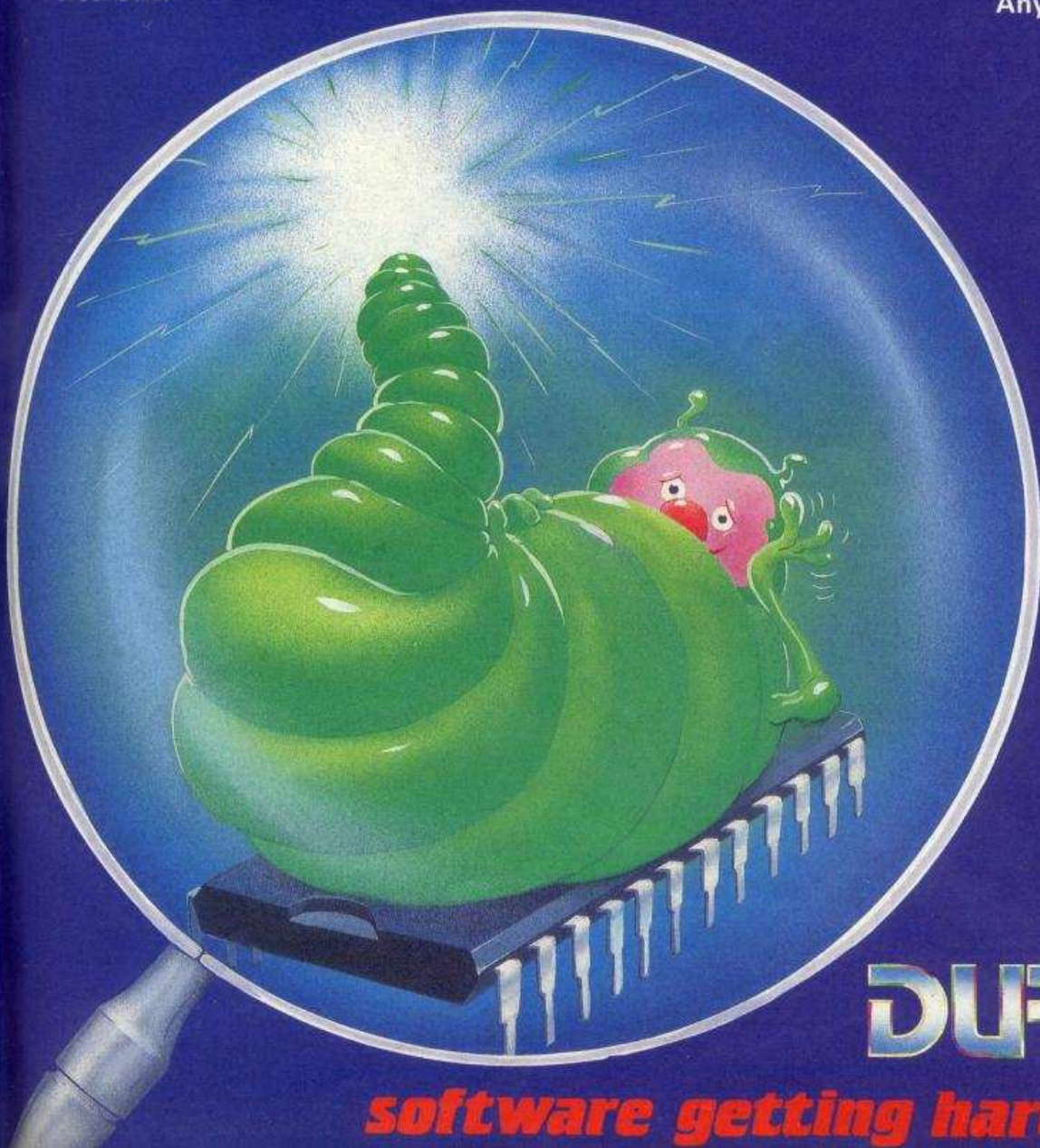

DURELL

software getting harder

QuickShot[®]

We've **TURBOCHARGED** the World's
Best Selling **JOYSTICK ...**

QuickShot 2 Turbo

* **EXTRA
PRECISION**

* **TURBO
RED BASE**

* **SIDE GRIPS**

* **12 MONTH
WARRANTY**

* **SIX MICRO-
SWITCHES**

* **AUTO-FIRE**

* **STABILISING
CUPS**



COMPATIBLE WITH:

- SINCLAIR ZX SPECTRUM (INTERFACE REQUIRED)
- AMSTRAD CPC 464/664/6128
- AMSTRAD PCW (INTERFACE REQUIRED)
- COMMODORE 64
 - VIC 20
- COMMODORE C16 (ADAPTOR REQUIRED)
- COMMODORE PLUS 4 (ADAPTOR REQUIRED)
- MSX
- ATARI HOME COMPUTERS
- ATARI 2600/5200 VIDEO GAMES SYSTEMS
- SPECTRAVIDEO SV1 738 X PRESS
- ACORN ELECTRON (INTERFACE REQUIRED)
- BBC (INTERFACE REQUIRED)

S.R.P. **£13.95** INC VAT

Available from:

W. H. SMITHS • BOOTS • JOHN MENZIES • LITTLEWOODS MAIL ORDER • TOYS R'US • ALLDERS
DEPARTMENT STORES • SPECTRUM • LEISURESOFTECH • RAM ELECTRONICS • SILICA SHOP
...and other computer stockists.

SPECTRAVIDEO LTD.
(A WHOLLY OWNED SUBSIDIARY OF ASH & NEWMAN LIMITED)

SPECTRAVIDEO™

165 Garth Road, Morden, Surrey SM4 4LH, England. Telephone: 01-330 0101 (10 lines) Telex: 28704 MMH VANG Facsimile: 01-337 5532

DANDY

Producer: Electric Dreams
Retail Price: £7.95
Author: Ram Jam Corporation

Dandy, the game that has inspired many clones, has been released by ELECTRIC DREAMS on the spectrum. Originally written by student John Palevich for the Atari as part of his thesis, the game went on to become a major hit in the arcades under the new name of Gauntlet. ELECTRIC DREAMS have converted Gauntlet back to home computers under the original name.

The scenario remains the same as in the arcade version. The player controls one of two characters, Thor and Sheba. The idea is

Your character can also arm him/herself with some pretty potent spells. These are identified as lightning flashes around the game. Using these, it is possible to rid an entire screen of monsters. Also, to keep your characters energy up, various tasty titbits can be picked up along the way.

The game has a two player option. If two people are playing then each person controls one character, with the object remaining the same. The characters are viewed from above, and the action moves from screen to screen in the



Thor approaches a bunch of meanies, but if he can get through the door, he can pick up the objects top right

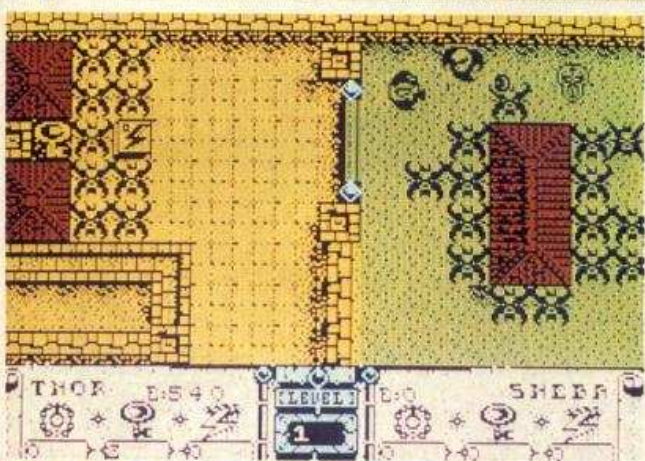
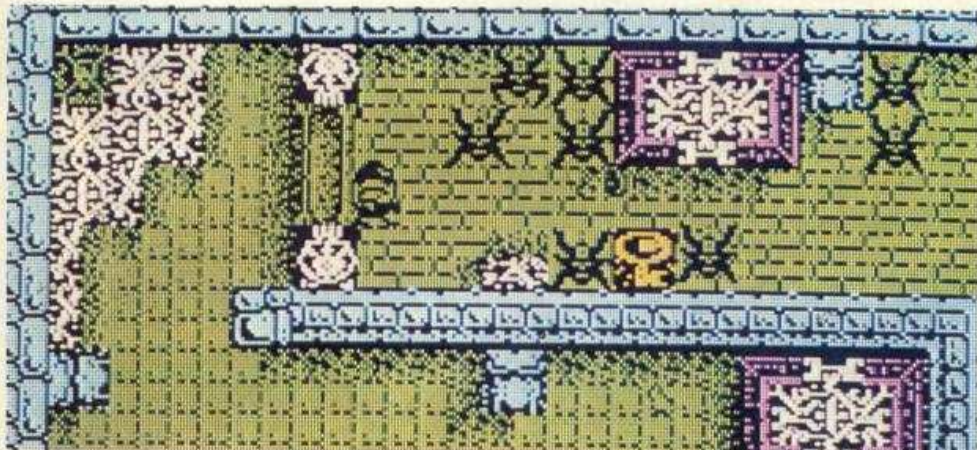

With the place really swarming with meanies, Thor's got his work cut out

to penetrate deep within the dungeons pillaging treasure. The dungeons, however, are inhabited by some very nasty creatures, mostly giant spiders. When you kill all the nasties in one screen, you must then disable the control box behind them. The treasure and other useful objects are contained within separate compounds in the dungeon. In order to move between these dungeons, keys must be found.

direction of your character. The character's status reports are at the bottom of the screen. A square box represents how much treasure has been collected, A key shows how many keys are in your possession and a lightning flash shows the number of spells safely nestled in your pouch. Between the two status charts is a small window showing which level you are on. Treasure can be traded for energy if your supplies get too low.

atures are well animated. All this said I must confess that I found the game quite boring after a few plays. Also, the sound only contains a few quiet spot effects. If you can't wait for the 'official' version of Gauntlet then this could be for you."

● "Gosh a Gauntlet variant, and it's a really good one too! The game is appealing from the word go and is easy enough at first to give you a real sense of achievement, and compelling enough to make you play on. The graphics are in the most part very good but they do get messy occasionally. The two player characters are nicely detailed and they move around very quickly. The sound however is a little disappointing. If you like this type of game then I strongly recommend that you give this a good eyeball."

COMMENTS

Control keys: Player One: Q=up, A=down, Z=left, X=right, C=fire, SPACE=Cast Spell (1 player mode), F=Cast Spell (2 player mode) R=Trade treasure for energy Player Two: P=up, L=down, N=left, M=right, B=fire, G=cast spell, T=Trade Treasure for energy O=Pause game
Joystick: Kempston, Sinclair
Keyboard play: responsive
Use of colour: understandably limited

Graphics: nice shading, inclined to get a little messy

Sound: some nice spot effects

Skill levels: one

Screens: twenty screens per level. Three levels in total

General rating: not a bad gauntlet variant

CRITICISM

● "Mmmm, though Dandy is a good game, I don't think that it's quite as good as Druid. The graphics and colour are excellent, but the game slows down to an awful extent when there are lots of characters on screen. What the officially licensed version of Gauntlet will hold though, I don't know. We wait with bated breath..."

● "ELECTRIC DREAMS have once again come up with the goods. The play area is well detailed containing lots of colour, and the little cre-

Use of computer	83%
Graphics	88%
Playability	85%
Getting started	84%
Addictive qualities	84%
Value for money	82%
Overall	84%

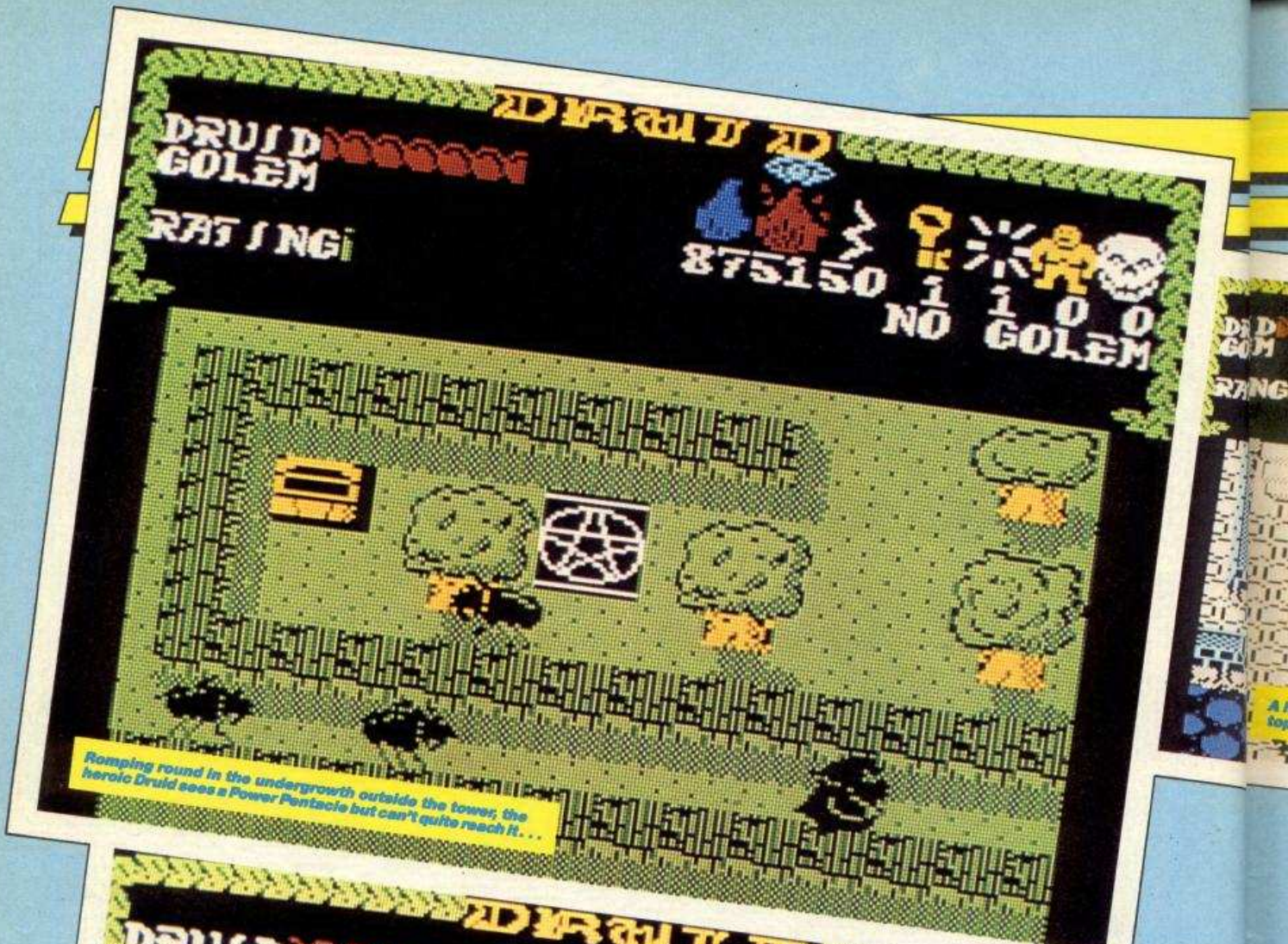

D·R·U·I·D

A
CRASH
Smash



Producer: Firebird
Retail Price: £7.95
Author: Andrew Bailey,
Dean Carter

Four skulls of immense evil have been brought together by the evil Princes of Darkness and placed in a tower. Gathered in the same location, their power to spread destruction, plague and dereliction is vastly amplified and the land is suffering. You, an aging mystical Druid, must destroy the evil skulls to thwart the Princes of Darkness.

The skulls reside in lower levels of an eight-level tower and the game begins in the fields surrounding the skulls' new resting place. You must penetrate the tower, defeat the demons, destroy the skulls and make good your escape.

The action is viewed from above and the flip screens that make up each level contain walls, or hedges in the open country, which combine to make up a maze of passageways. Demons scurry round the screens and need to be eliminated rapidly — contact with them saps the magician's energy, and the longer he stays in one place the more demons turn up.

The Druid can move in four directions, and can cast Water, Fire or Electricity spells with a press of the fire button — toggle between them with the P key. Each time a spell is cast the Druid's capacity for casting that particular spell reduces, and the counter under the respective icon decrements. Selecting the appropriate spell for the type of demon being attacked is an important factor of the game.

Apart from the workaday, fire-button-controlled spells, the Old One has four powerful spells at his command. Providing the inventory contains a supply of the appropriate spell material, these extra spells can be invoked with a press of the correct number key. The Key Spell opens doors; the Invisibility Spell hides the hero from the gaze of the demons for a while and temporarily immobilises them; the Golem Spell conjures up an assis-

CRITICISM

"Druid is amazingly good, and very easy to get into. The layout of the screen is excellent, giving a good mix of large characters and lots of colour — without any attribute problems at all! The game is smooth to play and contains loads of big, bad baddies. I like the way you can swap easily between different types of spell casting, and also the way you go around picking up different things from chests. This game is extremely addictive, loads of fun to play and quite different from your average 'run of the mill' arcade/adventure."

tant, and the Chaos Spell is a magical smart bomb that destroys all the nasties on the current screen. The Chaos Spell is the only spell powerful enough to destroy one of the skulls and has the pleasant side-effect of topping up the Druid's energy whenever it is cast.

Energy is added to the Druid's status bar when he stands on one of the Pentacles of Life that are scattered around the tower. Chests are a source of useful spellpower — all the Druid has to do is walk up to a chest and it will open to reveal its contents. Careful thought is needed before selecting an item from a chest, however, as the Princes of Darkness sense that one of their storecupboards has been opened the moment something is removed and destroy the chest and its remaining contents instantly.

CRITICISM

"Is this the start of a flood of variants inspired by the arcade game Gauntlet? If the rest are as brilliant as this, then we're all in for a good time. The gameplay is great — your Druid is easy to control, so whizzing around the place is great fun, although it is very hard to get anywhere as the rampaging nasties gang up quickly and tend to kill you off rapidly. After a lot of play, however, dealing with them becomes slightly easier. Graphically, Druid is presented well; the characters shuffle around smoothly and the playing area is highly detailed, with excellent shading. The sound is a little disappointing when compared to the graphics, but it is adequate. I strongly recommend Druid as it is playable and ever so compelling."

If things are getting a bit hectic, casting a Golem Spell invokes a handy acolyte. The Golem can either be controlled by a second player or by separate keyboard commands and it really comes into its own as a bodyguard. Your assistant can be given three commands: send, follow and wait, and has its own Energy bar that is reduced by contact with nasties. On the plus side, the touch of a Golem is instantly fatal to demons!

To play the game efficiently, care must be taken to select the right object from chests once they are

CRITICISM

"Oh yes. This game is superb, one of the best I've honoured my Spectrum with in a long time. Graphics are excellent, with lots of colour used over the various levels, and as far as playability is concerned, well, Druid is something else! Comparison with Gauntlet is, I suppose, unavoidable, but I would certainly like to see us GOLD come out with a better game than this — that'll take some doing! Everything about Druid is excellent: it's one of my fave games of the moment. And it's incredibly addictive too; if I didn't have to write this comment, I'd still be playing it. 'Nuff said?'"

opened. A map will prove essential if you are to stand any chance of achieving the legendary Light Master status — at the end of a game, one of sixteen rankings available is awarded, and they start with Halfwit...

COMMENTS

Control keys: 1 cast Key Spell, 2 cast Invisibility Spell, 3 cast Golem Spell, A control Golem, H and A control Golem separately from joystick, 4 cast Chaos Spell; Z left, X right, K up, M down, SPACE fire, P toggle Water, Fire and Electricity spells
Joystick: Kempston, Cursor, Interface 2
Keyboard play: responsive
Use of colour: neat, and without attribute problems
Graphics: fairly large and well detailed, with neat shading effects
Sound: spot effects only
Skill levels: one
Screens: large eight-level play area
General rating: A compelling demon-bashing game

Use of computer	87%
Graphics	91%
Playability	90%
Getting started	88%
Addictive qualities	90%
Value for money	88%
Overall	90%

W.A.R.

Producer: Martech
Retail Price: £7.95
Author:

The planet Earth is, once again, in deadly peril. This time it's not two geriatrics in Iceland threatening us all, but marauding aliens bent on conquest.

The aliens are approaching Earth in a fleet of huge cylinders. These contain cities, fields, factories, power stations, military bases and shoe shops - in fact everything needed for the alien equivalent of the good life. As the cylinders approach Earth, and prepare for the final assault on the planet, you are picked as our last hope. Your mission (should you choose to accept it) is to penetrate the defences of each cylinder in turn, and basically make a real mess of them.

The game is a vertically scrolling shoot-em-up. You fly over the surface of the alien cylinder blasting away at everything in sight in an attempt to destroy it. To do this, various parts of it's surface have to be shot up. Naturally there is plenty in the way of defences.

At the start of every cylinder, or when you lose a life, the game returns to an options screen. This allows you to view your score, or to buy various bolt-on goodies for your ship. You start out with a real bucket of a ship, but as time goes on, you can trade in your score for better weapons (or even buy extra lives). When your ship is completely kitted out, instead of the single front laser you started out with, you'll end up with a dual rapid fire front laser, with a single laser on the sides and rear - pretty hot stuff. But it'll need to be, 'cos it's pretty tough out there. There's not just enemy ships, but also plenty of bits of cylinder sticking up in the air which have to be avoided.

If all this still seems a little too

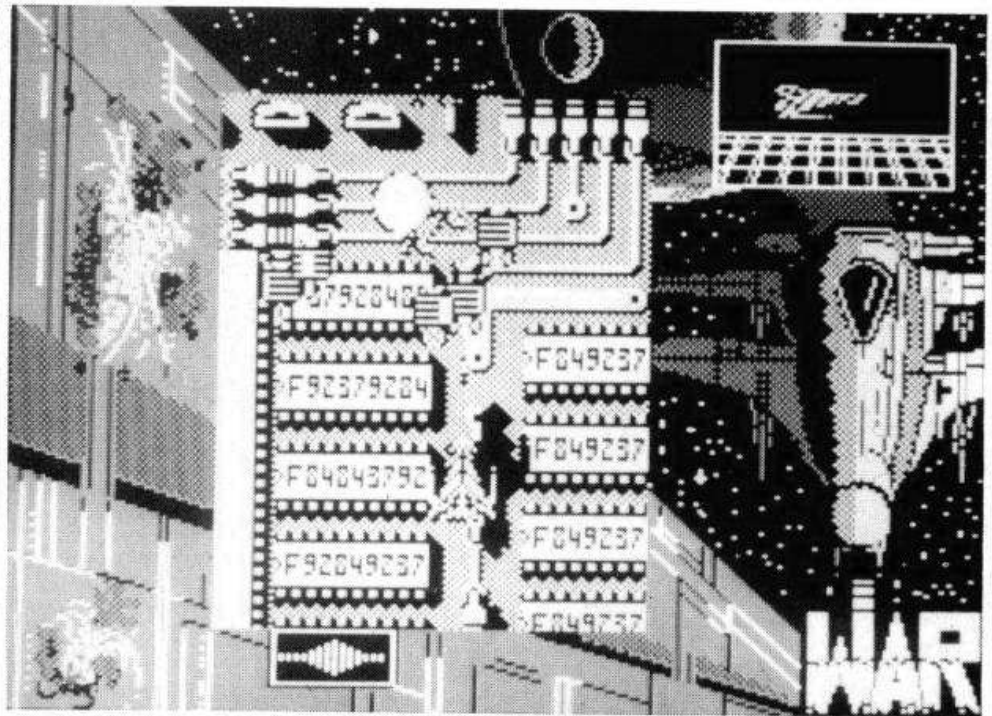

tame for you, then flip the cassette on to the 'B' side and you'll come across the beta version. This contains the same sort of game, but the scenery is totally different, and the meanies are far nastier.

CRITICISM

● "Let's face it guys and gals. If the Spectrum were meant to have a play area of about 12 by 16 characters then Uncle Clive would have designed it that way. I found it took ages to get used to the tiny play area. The scrolling is of an acceptable standard, and if it was full screen then I might have been impressed. Even though the game is a definite shoot-em-up I found it

Our hero getting a bit of gype from a large bunch of Drodians

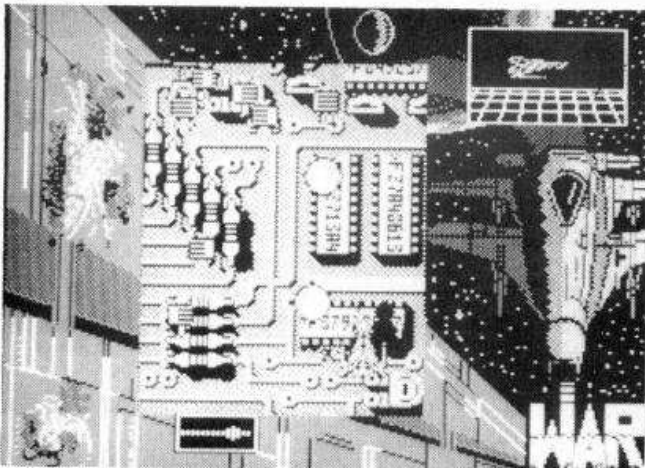

The hard level of the game; watch out for that big capacitor



very boring to play. I would suggest that everyone steer clear of this, as paying full price for a game that only ever uses one third of the screen is not what I would call value for money."

● "The pre-production copy appeared to herald a good game. So, when the finished version materialised in the office, I was eager to get my mucky paws on a copy (being the sort of person who looks forward to a good bit of destruction). The graphics are reasonable; the background screen is very colourful, but the game play screen is a lil' bit too small. Though difficult to an extent, I think that W.A.R. lacks something to keep the ol' adrenalin flowing freely."

● "You'll need a lot of patience if you want to do well in this one. The trouble is that you have to be phenomenally lucky to get through the first couple of levels before you can amass enough points to arm yourself to the teeth. After this point all you have to do hit the fire button/key extremely quickly, then sit back and let your fancy armaments do the work. The graphics are very pretty if a little cramped. The sound is very dull, no tunes and next to no effects during the game. On the whole I wouldn't recommend this as I wasn't at all compelled to play on.

COMMENTS

Control keys: Q left, W right, I up, J down, O fire
Joystick: Kempston, Cursor, Interface 2
Keyboard play: average
Use of colour: good in the border, but monochrome game window
Graphics: well drawn, but a small area
Sound: uninspiring explosion effects
Skill levels: two
Screens: five scrolling stages
General rating: Fast, furious and futile

Use of computer	60%
Graphics	75%
Playability	64%
Getting started	65%
Addictive qualities	64%
Value for money	55%
Overall	68%

INFILTRATOR

Producer: US Gold
Retail Price: £9.95
Author: Chris Grey and Paragon

Captain Johnny 'Jimbo Baby' McGibbets is not the sort of guy you'd want to meet at a party. Handsome, talented, strong, debonair, basically a total smartybottom. Not only is he going to bore you to death with some tale of derring-do in the skies, but that rather nice girl in the pink dress that you've had your eyes on for weeks is going to hang onto his every word, and eventually go for a quick spin in his Porsche (just to try out the new independent suspension you understand).

The first part of the game is all about reaching the enemy base. Once in the air, Jimbo punches up the old computer terminal. This gives him the heading of the enemy base. He then goes to the communication screen and punches this in to the beacon homer, then back to the main cockpit screen. The Gizmo is a bit unstable and keeps drifting off course. Jimbo only has just enough fuel to get to his destination, so it's essential that he keeps an eye on this.

Every now and then, a plane shows up. As soon as this happens, Jimbo shoots off to the comms screen and ask for the pilot's I.D.. The pilot comes back with his name, and asks Jimbo for his codeword. Depending on the name given by the pilot, Jimbo

must decide if he's friend or foe., and then give the right codeword. If he gets it wrong, then the plane attacks. The enemy's missiles must be dealt with using flares or chaff, whilst Jimbo gets the gook in his sights and blows him away.

Upon reaching the enemy camp, our hero engages whisper mode and silently descends. The next part of the game is loaded as Jimbo takes on the forces of the enemy on land. Again, infiltration is the name of the game. Jimbo has to bluff his way past the guards. There are three possible missions for Jimbo to be sent on, and they must be completed without him getting captured, blown up, or running out of time. But Jimbo can do it - he's that kind of a guy (prat).

The place is jumping with guards, but, cool as you like, Jimbo just shows his papers and listens attentively when the guards talk to him. If he makes it past the guards and through the minefield, he's got to search the buildings. This is done by searching cupboards for passes, keys and uniforms to help him move about without being caught. Jimbo has an arsenal of useful stuff like explosives, grenades and sleeping gas to help him.

CRITICISM

● "I've been playing the Commodore version of *Infiltrator* for ages and got nowhere with it,

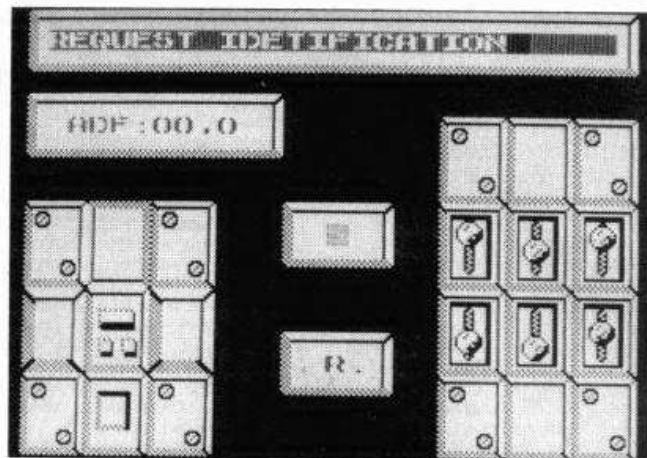

Decision time, give the wrong ID and you're in for a tough time

and now the Spectrum version turns out to be just as hard! This is a pity because the shots on the inlay look very good and worth getting to. The graphics are very well done, and contain lots of colour. The game itself is smoothly animated and full of fast action. If you can work out how to play it then I'm sure you'll enjoy it.

● "Hmmm! I'm not too sure about this one, the idea is great and the way in which it's presented ain't bad, but the US GOLD team have made it a little too hard to get into. Flying around the countryside shooting down the various enemy planes is fun, but you get killed off very quickly so I haven't got into the next section yet - Ho-hum! The graphics are quite good and the sound is about average for this standard of game. If you like challenges then perhaps this is the game for you."

● "Long awaited, but is it worth it? As usual, I don't really think so. The graphics are very pretty, but the game is too difficult to be any good. The whole thing is very well presented, but I don't really like it all that much. 'Nuff said? (NO!! - Ed.)"



COMMENTS

Control keys: A down, Q up, O left, P right/papers, CAPS SHIFT fire, B battery, S initialise/sleeping gas, I ignition, G guns/grenades, M missiles, F flares, C chaff, H Head up display, W Whisper mode, 4 Comms, 3 computer, T boost, SPACE inventory, M mine detector, E explosives, C camera (phew!)
Joystick: Kempston, Sinclair, Cursor

Keyboard play: O.K. once you get use to where everything is

Use of colour: attractive

Graphics: workmanlike

Sound: clicky

Skill levels: one

Screens: scrolling area, three parts

General rating: well nigh impossible, leave it to Jimbo

Use of computer	79%
Graphics	79%
Playability	70%
Getting started	69%
Addictive qualities	70%
Value for money	70%
Overall	72%

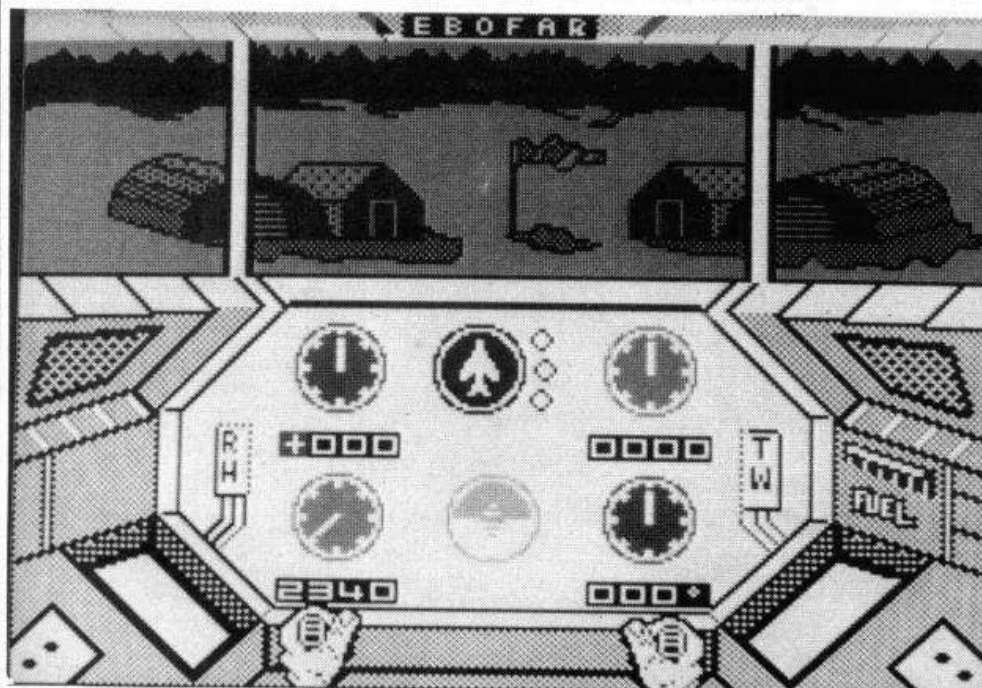

Jimbo at home base ready for take off

GALVAN

Producer: Imagine
Retail Price: £7.95
Author: John Gibson and Karen Davies

One by one the brave members of the Cosmo Police tackled the unspeakable evil on the planet Cynep. Alas the wallies all failed in their bid to rid the Galaxy of the Cynep rule. Now there is only you, Galvan, left. All alone you must try to achieve what many have failed to do before. Using your wits and ingenuity you must scour the planet Cynep, venture deep within its Techno Caverns, and attempt to kill each one of its evil inhabitants.

The planet Cynep is populated by some very strange and dangerous beings who are extremely possessive about their domain. Ram-paging robots turn out to be pretty talented with the old left hook, and before Galvan can manage to pick up a weapon he is forced to box it out with these scowling metal machines. Apart from the robots there are the native aliens. These aliens seem to appear out of nowhere and their attacks are sharp and accurate. To begin with you only have your bare hands to defeat these nasties. Even against the robots this is quite difficult but when up against the fast moving flying aliens you really don't stand a chance.

Things however are not as futile as they may seem. Those Cosmo

Police who went before you, left their weapons behind as a sort of morbid reminder for those who were to follow. These weapons come in the form of power pyramids. When Galvan first picks up one of these power crystals it provides him with the ultimate hand held weapon - the Blue Bolt Neutraliser.

As usual there's a snag; when Galvan's power is drained to a certain level his weapon becomes less effective. First it changes to an Arc Blaster, then to a gun, and finally you're on your own again with just your fists. Luckily the power pyramids are scattered quite liberally, they can also be collected from space-suited aliens when they've been killed.

Apart from the minion nasties, the end of each of the Techno Caverns is guarded by a ravenous multi-headed demon. Before Galvan can progress any further into the game this monstrosity must be destroyed. Each part of the demon must be shot four times before it is rendered harmless.

This life-and-death-mega-battle takes place at several different venues. These range from the arid platforms to the Techno Caves to deep underwater, where savage sting-rays and salivating sharks are already sharpening their molars in anticipation of an early lunch.

Galvan moves around the planet Cynep on foot. When necessary however, he can leap to great heights in order to avoid something nasty or to get to a higher platform. Galvan has five lives, and one of these is lost each time his power level reaches zero. There is also a two player option.

Galvan has picked up a weapon and really lays into a nasty looking serpent

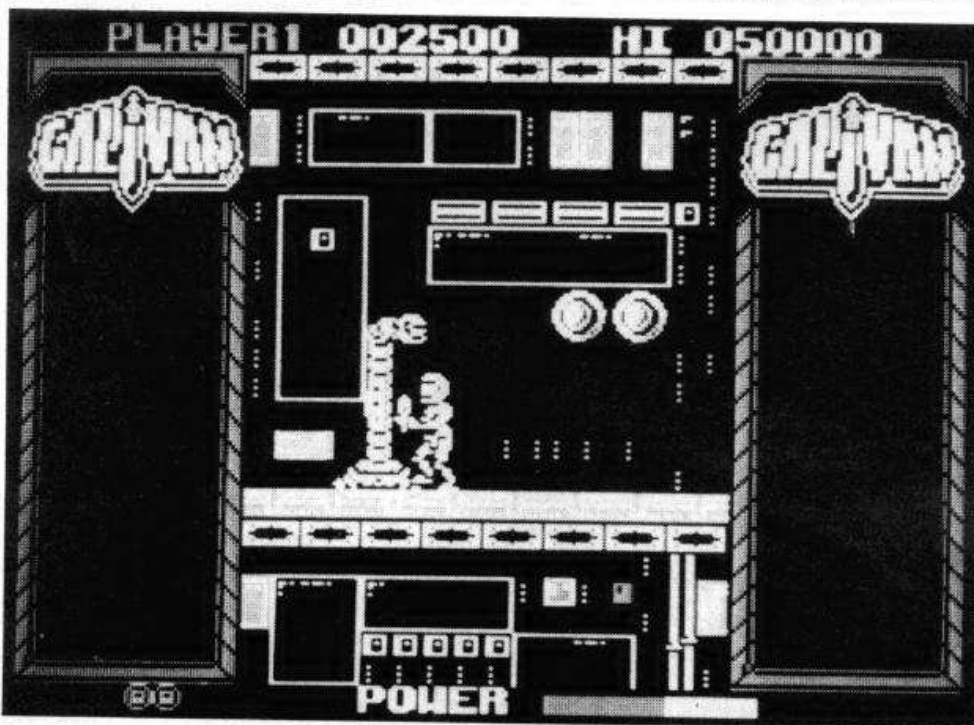

CRITICISM

● "I can forgive IMAGINE once - for Tennis - but when they start to bring out games like Galvan, then I start to worry. I can't see what IMAGINE think that Galvan has got. It's certainly not the graphics, and the sound is nothing special either. The way that the screen scrolls (in all directions) would be very nice if it actually worked, instead it turns out to be jerky and offputting. I'm not too impressed with Galvan and I'm very unhappy that IMAGINE have started to release this inferior stuff."

● "On my first go of Galvan I felt somewhat chuffed on reaching the first Demon. But then I reached another, that Galvan has got. It's certainly not the graphics, and the sound is nothing special either. The

way that the screen scrolls (in all directions) would be very nice if it actually worked, instead it turns and continued the same game for more than a quarter of an hour; this, by my standards is not the sort of difficulty level I expect to find in any arcade conversion. The scrolling is very poor, and the sound is a further reflection of the game's lack of polish. This is definitely not up to Imagine's usual standard. Pull your socks up, IMAGINE."

● "This is the sort of game you can play for half an hour on your first go, get an enormous mega-high-score and then never play again because it was so boring! Legging it around the incredibly large playing area zapping, shooting or punching hundreds of nasties (and surviving by luck alone), didn't really get me going. The graphics are very messy and disappointing. The action takes place on a tiny section of the screen which scrolls abysmally, and the use of colour on some screens makes it difficult to tell what's going on. The sound too is pretty dire, with few effects. On the whole I'm dissatisfied, it could have been much better."

COMMENTS

Control keys: definable
Joystick: Kempston, Protek/Cursor, Sinclair, Fuller
Keyboard play: fairly good
Use of colour: colourful, but attribute problems
Graphics: very slow scrolling
Sound: a totally unsyncopated tune at the beginning with spot effects throughout
Skill levels: one
Screens: jerky scrolling play area
General rating: will disappoint arcade devotees

Use of computer	63%
Graphics	64%
Playability	67%
Getting started	71%
Addictive qualities	67%
Value for money	62%
Overall	65%

THE Clearance Sale You've Been Waiting For
KLEIN'S CENTRAL WAREHOUSE OUTLET

Under ONE giant roof, hundreds of nationally advertised Household Appliances.

NEW SAMPLES

Vacuum Cleaners
 Salesmen's samples
 all makes from \$5.95

Washers & Ironers
 New family size only \$19

ABC Spinner.
 Sensational at only \$35

Oil heaters
 - free installation - from \$30

Odds and Ends. Famous makes.

Free delivery.
 No finance company to deal with
 300 N Madison Rd. Wabash 5148

OPEN SUNDAY

Buy direct Factory samples
 Bedroom sets \$29 up
 Parlor sets \$19-\$39 up
 Trade-in & repossessed furniture available

Schwarz & Co 4077 Cottage Rd W

CHEV '39 Sedan \$400
 Trunk heater, vacuum gear shift, bumper guards, original fin. Priced far below market. Private

Krueger Humboldt 9226

CODE numbers needed for Wheelie player. Reply Box 63980

St. Louis \$4.75 Detroit \$5 Ft. Wayne \$3 Columbus \$6

De Luxe Motor Stages
 230 Milwaukee N W Lake Central 3131

Will exchange dental work for used car.
 J F Ball Drexel 4113

ALL AMERICAN BUS TRAVEL CO.

Free pillows Free meals
 Los Angeles \$30 o/w \$54 r/t
 S Francisco \$32.50 o/w \$60 r/t
 Miami \$15 o/w \$25 r/t
 Atlanta \$10 o/w \$14.50 r/t

LOWEST ROUND TRIP FARES IN THE STATE.

SPECIAL SALE

Now - from only \$29.50
 New, de luxe, water heaters.
 kerosene; gas

217 W Washington Av. Franklin 1300

Not responsible for debts except those contracted by myself.
 J Schaeffer 3351 Washington

BARGAIN!

Fluffy Pork Pie Sport Felt.
 Regular \$1.49 Value. The all purpose casual felt in Black, Brown, Soldier, Wine, Red, Kelly, Beige.
 Four head sizes 21 1/2-23. Now ONLY 84c

OLIVERI HOTEL - 300 W. 31st St. Day. Lg rooms; new furniture; pri. bath, tub & shower.
 200 N Oak - Sheridan Rd Sheridan 8641

5000 SINCLAIR C5s. for sale. Going cheap. Batteries not included. Victory 2210

AUTO LOANS

CASH IN TEN MINUTES ON YOUR AUTO OR TRUCK 20 MONTHS TO PAY

Deal direct with owners. Private consultation rooms.

HIRSCH-DAVIS

20 years in the same location
 6213 W STALLWORTH ST. Harrison 2217

VISIT Paula's Puppyland - Air Conditioned. All pop. breeds. 100s to pick from. Low prices. 6162 N Harlem Av.

STENOGRAPHERS

Complete secretarial courses. Learn by actual work on switchboards. Free catalog. Also 'Brush up your Comptometer' 'Complete X-ray Course'

AMERICAN BUS. COLLEGE
 20 E Michigan

Would anyone having knowledge of the whereabouts of Joe 'Pug Nose' Morelli please tell his mum cos his tea's ready.

WALTZ, fox trot, rhumba. Private lessons. 7 for \$5. No appt. nec.
 Rm. 21 316 N Clarkson Wkdays 10-5

ALLIED BEAUTY ACADEMY 32 E LAKE ST

MANICURING COURSE \$17.50
 Jobs waiting. Learn in 3 weeks.

Includes tools, diploma, placement service

CONFIDENTIAL ENQUIRIES UNDERTAKEN

Contact Sam Cruise. Fairfax 7337

PENTHOUSE - living room + kitchenette; 2 bedrooms & private roof garden. Combining tub & shower, circulating ice water. Complete service.

At an address of distinction.
 35 W Delaware Franklin 3911

Sinclair C5 Sedan. 4 door. Fully air conditioned. Running boards extra. This car will pass for new. Any colour you like, as long as it's white
 Reply Box 63980

WINTER COAT SALE!

Hood coats, wrap arounds, warm fleeces, heavily interlined, coats with lined snow pants to match. Sizes 12-20
 From \$14.98. Value \$25

EMERSON COAT CO. 2342 W CENTRAL AV.

\$1,000,000

in diamonds WANTED!

The Very Highest Prices will be paid
 We also purchase Old Gold & Pawn Tickets

YOU RECEIVE CASH IMMEDIATELY
 US Diamond Syndicate, 35 N Pulaski Rd.

MARKSHALL ARMS - Ideal for executives. Fashionable conveniently located. Excellent cuisine. Attractive monthly rates. Every room with private bath. Coffee shop. Barber & beauty shop.
 4100 La Salle Nth. Fairfax 6265

CASABLANCA nite-spot needs pianists. Apply Rick. Box 63980

1290 PINE GROVE PLAZA Modern de luxe 6-7 rm apts. Newly decorated. Electric elevator. Lg. closets, v. lite

ARTIFICIAL leg - Man's; left; size 7 1/2-8. Airplane metal, lightweight.
 Delaware 7173

PART share in 1936 Cab \$45. Fly solo \$1.50 Dual \$3.50 Evenings. Oak Lawn 1904

FOR SALE. 20 Left shoes, size 7 1/2-8. Going cheap. Offers Delaware 7173

LABORATORY equipment for sale - chemicals, scales etc. Perf. cond.
 Calumet 2071

4 yr old saddle horse. Well mannered. Sacrifice. Quick sale. Offers.
 Mr Edge. Oak Park 1397

TEETH lost - partial plate.
 W 79th St. Reward Wellington 2354

DRIVING to Denver, Cheyenne via Oklahoma shortly. Take 2 share expens.
 Kedzie 4031

Gas driven calculators; adding machines; cash registers & ZX81s. No reasonable offers refused.
 Mike's Second Hand Bargains. 15 Grand Av (nr Plaza)

OLDSMOBILE '38 Del. Trk. Sed. \$550 4 door model. Heater, very clean. \$45 down.
 Mayrling Motors 6800 24th & Michigan

SALESMAN - 44. Aggressive. Seeks good side-line to work into full-time prop. Have car
 Anderson. Irving 4519

WOODLAWN 1362 - 2 rms. Pri. entrance. Newly furn. & decor. Frigidaire. Gas incl. \$3-\$6

Quick drying cement supplied. No questions asked. Apply Box 1342

Yng hi-sch grad. desires off. wk or reception. Hollycourt 7373

STUDEBAKER

1940 President Sedan.
 Gleaming grape-tone maroon finish. Equipment includes radio, climatizer etc. Exceptionally low mileage. Like new \$895

2435 W WABASH Independence 3310

City Officials bought and sold Box 2217

INDIGESTION MAY AFFECT THE HEART

At the first sign of distress, smart men and women depend on

CHESTER'S PATENT REMEDY
 made of fastest acting medicine for acid indigestion. If the first dose doesn't prove CHESTER'S best, return bottle to us and receive DOUBLE money back. 25c

ring for furniture. Kildare 3927

New & used violins & cases. Bargain prices. Telescopic sights optional.
 423 S Clark Blvd. Open even.

PACKARD '40 deluxe Sedan \$750 Used 5 mths. 4dr trunk. Radio & heater. Liversay Lakeview 3074

Beauty Operators Trained at DE VERE UNIVERSITY

are in the State's leading salons. We take pride in their success. Rates, terms catalog on request. No obligation.

Day/evening classes
 De VERE 50 E RANDOLPH BLVD. 7th Floor

BLACKSTON PK 3125 - 1/2/3 rm kits well furn. newly dec. \$3.75-\$5 up

HAYLEY, I luv u. Eric. XXXXX P.S. Will you help me with my lines
 Reply Box 63980

Ellis 4535 - 2 rm basement apt. Kit. elec frig. Free gas \$5-\$9

LAUNDRESS. Good shirt ironer. Cleaning. Fast worker. Triangle 4200

Can't get across river in Omnical? You need the Extension Kit.
 Reply Box 63980

Mens Vests \$1.98 Corduroys French backs; molenkin fabrics. Dark colours, all excellently tailored & strongly reinforced for real wear. Sizes 30-42
 No Mail or Phone orders - none delivered.
DACRE'S BARGAIN BASEMENT
 139 N CLARK ST

PAINT, paper \$3 up per rm incl. paper. Baths enamelled. Plaster; patch.
 Independence 7668

1500 used theater seats. Also theater organ. Baldwin baby gr. piano. Cheap. Schoenstadt. Archer 2554

CATAFULT required for Skooldaze player
 Reply Box 63980

9 x 12ft. Mothproof Rug Pads. Offers around \$1.95
 14 E Jackson Evenings only

Doll baby - please write me at mothers. Joe is sick Sweetie Pie.

Cadillacs lengthened to your requirements. \$288 per yard.

SLOPERS METALWORKS EARLSWOOD ALLEY
 (back of Joe's Drug Store)

FULLY FASHIONED RAYON OUTSIZE HOSE

All well reinforced, knit to fit, with stretch tops, Irregulars of 39c value.
 9 pairs \$1. Sizes 9 to 11

THRIFTFOOD MART

Diced fruits - per lb 27c
 Sugar peas, sifted, 6 cans 65c
 Tea balls - 100 to box 75c
 Premium hams - per lb 19c
 Cane sugar, pure grain - 25lb \$1.15
 32 S LA SALLE ST. 9 - 9

OLYMPIC F Lg rooms; n & shower.
 200 N Oak - 5000 S
 Going cheap

CASH IN A 20 Des Priv

20 yr 6213 W STA

VISIT Paula Conditioned pick from. Low prices

Complete actual work. Free catalog. Also 'Brush' 'Comp' AMERICAN

Would anyone whereabouts please tell h

WALTZ, fox 7 for \$5. No Rm. 21

ALLIE

MANIC Jobs w Includes too

CONF

Contact Sam

PENTHOU 2 bedrooms Combinatio ice water. C

At ar 35 W Delaw

Sim Fully air co extra. This colour you

W Hood coats heavily inte pants to mu From \$14.9

in

The Very H *We also pi Pawn Ticks

YOU REC US Diamor

PAWNBROKER clerk, jeweller - AJ salesman. Alert, live-wire; draft exempt; 8 yrs exp. Columbus 6823

113 Lincoln Av - 3 rooms well furnished. 1/2 ba. 1/2 bath. 1/2 shower. Double fronted. 4 beds

FOR AIRPLANE & STEAMSHIP TICKETS, SEE: WHITWORTH & RAYMONDS TRAVEL 211 W WASHINGTON 6131

ELLIS 2329 - Attr. 3-4 rm apts with kitchenette. Pri. bath. Comfort furn. \$7 up

CRM en... information on... Reply Box 63980

FOR SALE GROVER HAS THE TRUCKS

Save on price. Gain on quality. Reconditioned used trucks. Safety laws inspected.

PAWNBRO salesman. 8 yrs exp.

6134 Ince

New from



48K Spectrum £7.95
MICROSPHERE
 72 ROSEBERY ROAD LONDON N10 2LA

CONTACT SAM CRUISE

Thanatos has a bit of trouble with a local human who insists on lobbing spears at his scaly hide. Nasty man must have read too many St George stories



A paddle in the sea is just what the heroic beast needs to cool his claws

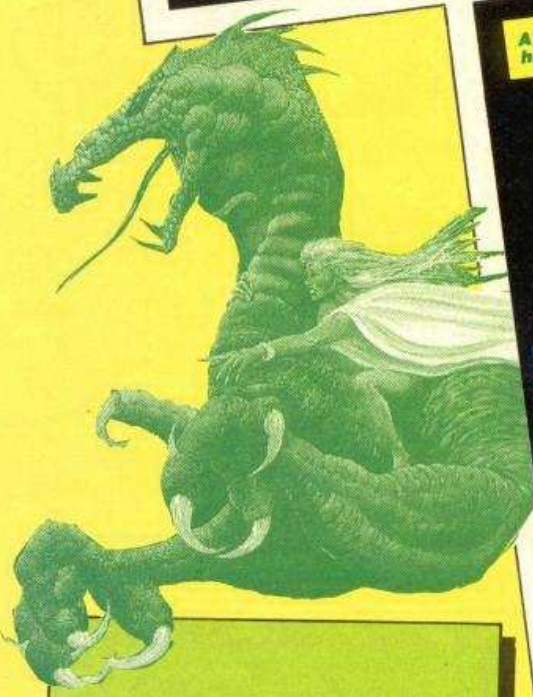
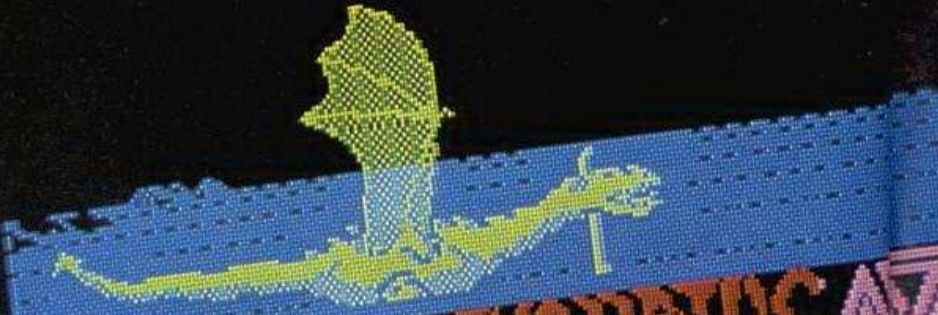

Producer: Durell
Retail Price: £9.95
Author: Mike Richardson

Let's face it, the dragons of this world have had a pretty bad press. Ever since George did his bit of dragon bashing, people have been going around being very butch and sticking it to these badly misunderstood creatures.

Quite understandably, the dragons have always resented this. Lovers of the peaceful life, con-

CRITICISM

"I was very impressed with my first game of Thanatos: the graphics are well up to the standard of recent DURELL successes and the game as a whole is extremely original in look and play. The movement of the main dragon is very smooth and realistic, and all the characters, from bees to sea monsters, are well drawn and contain lots of colour. I found it very easy to get into and highly addictive, even though it presents the same problems in the same order every time. The game is well presented, but I feel that it is a little too hard so that you may end up missing out on quite a lot — which is a pity as it is quite expensive. Another very decent game from DURELL."

stantly being harassed by these tinplate tinheads just didn't fit in with their lifestyle. Thus, in order to be able to put their feet up and get a good (knight's) kip, your average dragon has to torch a good fifty mile radius around his home just to be sure of a bit of 'ush. And thus the legend of the bad old drag' with a breath problem was born. So, he makes a snack of the odd maiden or two? Well, nobody's perfect!

In a bid to rehabilitate the image of these poor old creatures, Mike Richardson has forsaken his previous hi-tech worlds of fast cars and high flying helicopters for a more rustic setting.

In this pastoral land, the good dragon — Thanatos the Destroyer — must do his duty. The good Sorceress Eros has been imprisoned by an evil Lord of the underworld, and to add to her problems the rest of her belongings — spell books, trusty cat and so on — have been locked up in separate castles. These must be restored to the Sorceress so that she can bring light and enlightenment to the land, and forever clear the good name of dragons.

The Dragon is controlled by joystick or keys with up, down, accelerate and decelerate. Hitting the fire button does just that — the Dragon breathes fire, either up or down depending on the up/down keys. Pressing fire and the decelerate key causes the dragon to reverse direction.

The action takes place against a scrolling background. Thanatos and the meanies move in the foreground while mountains and villages in the background scroll past more slowly giving a perspective effect. All the meanies and Thanatos are animated: men throw spears, gulls wheel around in the sky and sea serpents writhe in the sea and plunge back into the water.

The dragon flies through the air by flapping his huge wings, waddles around on the ground on claw, or can paddle and swim in the sea. To take off, just trudge along and press the 'up' key. Apart from bre-

CRITICISM

"Eyes popped at the CRASH offices when we first saw the preview copy of Thanatos, and the final version is even better! You get totally enthralled in the mystic scenario. This is one game that I can't really see myself leaving alone for weeks. Graphically what can I say? Thanatos the Wyvern (it ain't a dragon 'cos its only got two legs) is the best character I have ever seen on the Spectrum. All the other characters are very nicely done, as is the countryside which scrolls astoundingly. This is the best game I have played for months, even at ten quid it still represents good value."

athing fire, the drag' can set about his foes by picking them up with his talons and carrying them aloft. They are dropped again by pressing fire, and plunge to their death. By hitting another baddie with the falling body, two 'birds' can be killed with one stone and extra points won.

The higher the level, the more damage is done to the dragon with each brush with a meanie. These come in various shapes and sizes. Killer bees mob him, nasty two-headed dragons give him a hard time, sea serpents are out for his blood and deadly spiders hang from silver threads in the caves. On the ground he comes up against the odd pack of wolves, and has to cope with soldiers chucking things at him.

Thanatos's life force can be restored by taking a quick breather on the ground. His life force is shown by a beating heart and as he takes damage the beat quickens. If he gets really badly dam-

CRITICISM

"Wow! This game is really amazing; stunning, astounding, brilliant! The tune on the title screen is very nice, but the graphics are absolutely superb. The parallax scrolling works excellently, and the effect that it creates when you belt past a path, the castle, or a beach, is breathtaking (almost!) Playable and addictive, Thanatos is a game that I'll be playing for a long time to come; if variety is the spice of life then buy this and become a chicken curry."

aged, the heart turns blue. If he runs out of fire, he has to refuel by taking a quick snack of nasty witch. But watch out for the knight on a white charger doing his dragon slaying bit. The only way to deal with him is to grab him with your talons while he's galloping along — very tricky.

To win the game, Thanatos has to rescue Eros from one castle, and then take her on his back to other castles to collect various objects. There are three castles on the lower levels and four on harder levels, and it's no day trip rescuing damsels when you're a dragon...

COMMENTS

Control keys: redefinable, up, down, left, right, fire, P to pause
Joystick: Kempston, Cursor, Interface 2
Keyboard play: good positive feel
Use of colour: excellent, but badly masked
Graphics: gibber, gibber
Sound: a haunting tune, but beep, cough, burp effects
Skill levels: eight
Screens: scrolling
General rating: An excellent and rather different arcade adventure.

Use of computer	94%
Graphics	95%
Playability	92%
Getting started	91%
Addictive qualities	
	94%
Value for money	90%
Overall	93%

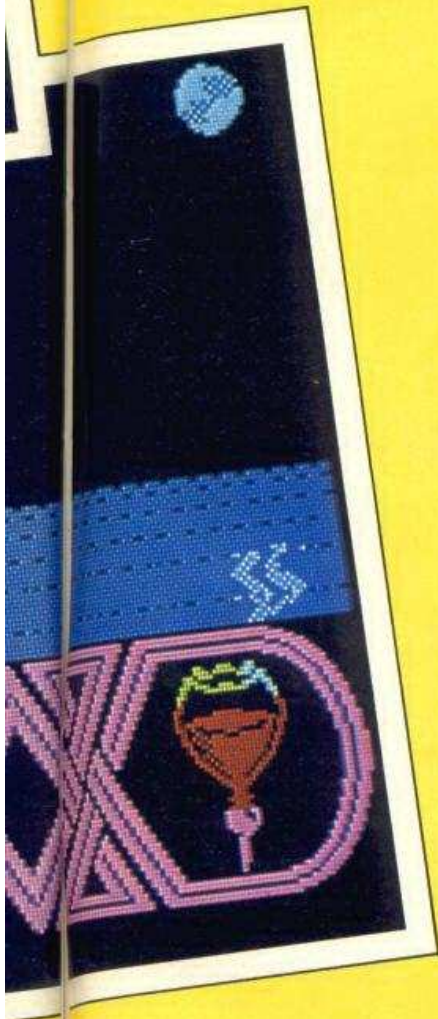

THE- ARCADE MASTERS

"The Most Outstanding Coin-Op
Game of the Year!!"

Sega™ invite you to take a trip to the
Fantasy Zone in the fascinating 3D-Action
game that set the Coin-Op world alight.

Steel your nerves, alert your senses and
prepare for a thrilling trip into the future.

After months of development he's finally
here—Scooby in his own hilarious computer
cartoon. Designed and coded by Gargoyle
Games, Scooby Doo is a fast-action arcade
game that's as funny to watch as it's exciting to
play—Scooby-Dooby-Do!!

COMMODORE 64/128

AMSTRAD SCHNEIDER

elite

© 1986 Hanna-Barbera Productions, Inc.

SPACE HARRIER

COMMODORE 64/128

SPECTRUM

elite

© Sega 1985

Screen shots taken from various computer formats

Spectrum	Cassette	£7.95
Amstrad	Cassette	£8.95
Amstrad	Disc	£14.95
Commodore	Cassette	£9.95
Commodore	Disc	£14.95
C16	Cassette	£7.95



Mail Order, just send a cheque or postal
order payable to Elite, or quote your Credit
Card number.

Elite Systems Ltd.,
Anchor House, Anchor Road, Aldridge,
Walsall, West Midlands, WS9 8PW.
Telephone: (0922) 59165.
Telex: 336130 ELITE.G.

elite

Super Cool and Part of the Team with the CRASH Outfit.

The Complete

CRASHMAN!

Caps: designed to set off your T-shirt or Sweatshirt, the blue CRASH 'baseball' style cap with white embossed CRASH logo, is ideal for anywhere, any time. Adjustable strap ensures one size fits all.

£3.95

T-Shirts: emblazoned with the famous CRASH logo and Olibugs, they come in three sizes made in black from 100% cotton with double stitching on neck and shoulder seams for lasting wear.

£4.50

Chest sizes
 Small 34-36in
 Medium 36in
 Large 40in

Sweatshirts: same imprint as the T-shirts, long sleeved, heavy quality and fleecy lined with double stitching on neck and shoulder seams. Three sizes available in dark blue.

£8.95

CRASH BINDERS

Each binder holds twelve issues of CRASH held in place by small plastic straps for ease of access. The year is also marked on the spine. The binders come in a rich blue with silver logos on the face and spine and come to you solidly packaged in their own boxes.

£4.50

CRASH T-SHIRTS/SWEATSHIRTS/CAPS/BINDERS OFFER

All quoted prices include VAT, post and packing (UK only). Continental Europe and Overseas, please add £2 extra per item ordered.

Please tick the appropriate box. State Size S M L XL
 Form in capitals please.

- Please send me CRASH T-shirt(s) at £4.50 each.
- Please send me CRASH Sweatshirt(s) at £8.95 each.
- Please send me CRASH Cap(s) at £3.95 each.
- Please send me CRASH Binder(s) at £4.50 each.

Name
 Address

Postcode
 I enclose £ made payable to 'CRASH'
 Cheques or postal orders only, please.

**'COMPLETE CRASH OFFER', PO BOX 10,
 LUDLOW, SHROPSHIRE SY8 1DB**



MAGMAX

Nichibutsu
Nichibutsu
Nichibutsu

SPECTRUM
£7.95
COMMODORE 64
£8.95
AMSTRAD



Nichibutsu's arcade hot-shot on your home computer now!

If you haven't already played it in the arcades then you're in for a *real* surprise – if you have then you'll be going Mag Max to load it into your micro. Mag Max could be a mean machine if you've got what it takes to put him together. Build him up and his fire-power increases – you'll need it! – believe it!

Imagine Software · 6 Central Street · Manchester M2 5NS · Tel: 061 834 3939 · Telex: 66997

PREVIEW

Coming soon to a Spectrum near you!

AUTHENTIC ACTION FROM THE ARCADES



Zooming across the chequerboard landscape, our hero's got it easy to start with

From those arcade specialists **ELITE** comes another faithful arcade conversion. If you venture down to any arcade, you can't miss the *Space Harrier* machine. With a pneumatic seat and a screen mounted on a hydraulic arm which moves as you play, it's pretty hard to overlook.

When **ELITE** announced it had brought the license for this game,

few people expected anything more than a rather nasty shoot-em-up which would be sold to maniacs who were fans of the arcade. But, as the game nears completion, it looks like **ELITE** are going to confound all of us. The animation and perspective effect, as the jetpack trooper swoops and sways across the landscape is hard to believe.



At the end of the first level, this fearsome beast must be tackled - he can take a lot of punishment, and hand it out as well

The trooper has to get through sixteen levels, each harder than the last, dodging or blasting everything that moves. Each level features different meanings and landscapes. On higher levels, there are lots of indestructible obstacles that have to be dodged around. At the end of each level, the trooper faces a particularly tough old meanie. In the first level, this takes

the form of a dragon which rushes towards and then darts away from you, and has to be heavily blasted before finally it disintegrates, and you go on to the next level.

From what we've seen, this could be one of the most visually stunning shoot-em-ups for some time and one we're sure the arcade fraternity can't wait to get blasting away on it.

WINGE WINGE, MOAN MOAN, GRIPE GRIPE

Getting this year's award for sour grapes, *Peter Shilton's Hand Ball Maradona* is all about a certain little incident involving an English goalkeeper and a rather small Argentinian who has a full set of ball skills, including some which involve the use of his hands!

Can you learn to keep goal like

the great Mr. Shilton himself? This game takes a unique standpoint for a computer football game, you control the goalkeeper only. The enemy forwards are attacking, and you have to foil their shots.

Obviously, as you only control one player, there are a fair number of ways to control him. There are a

grand total of seven different types of dive. When the forwards are running towards you, the goalie can be moved around the goalmouth to try to 'cut down the angles (Brian)', and then, when the ball is clobbered in the direction of the goalmouth, you have to decide the right moment to dive for the ball. Pulling the joystick down and to the side produces a low dive, just

to the side produces a moderate height dive, and pushing up and to the side makes the goalie go for a lunge through the air.

In two player mode, both players take it in turns to save shots, four shots each, and the player who saves the most wins. There are a number of skill levels. To reach a new skill level, each player has to attempt to save four shots, if they save all four, then a code number is given which can be re-entered whenever the game is loaded to restart at the same level. At higher levels, the shots are a lot faster, and the forwards are less predictable.

Another problem for would be Shilton's is that the goalie can't advance any further than the edge of the six yard box. Even worse, he can't even do his usual shouting and screaming to the defenders, much though they deserve it, they just stand around and let the opposing forwards get on with it. On the plus side however, he doesn't get anyone trying to kick him, as attackers don't try to follow up their shots, and there aren't any pint size dirty Diego's trying to play volleyball.



Oops! Peter's goofed again as another real blinder beats him to the nearpost (I just stuck me boot out and there it was in the back of the net)

PREVIEW

ZUB THE ANTIHERO

Are you tired of playing yet another muscle bound meatead? do you long to be normal just once? Then Zub from **MASTERTRONIC** could be right up your street.

Private Zub isn't the greatest fighter in the Zub army, in fact he's one of the worst. However, for some strange reason he has been chosen to venture into the Zub zone to recapture the Green Eyeball of Zub, which has been stolen by King Zub's treacherous brother.

As you may have gathered by now, *Mastertronic* has not really gone overboard on place names. Just about anything in, near or even vaguely associated with this game is called Zub.

You have to get from planet to planet using the ancient,

antiquated teleport system. This has fallen into disuse because no-one else is daft enough to use it, what with the ongoing war amongst the planets, the unreliability of the teleport system, and well, just plain agrophobia. Having your molecules scattered over half the solar system is quite an awe inspiring experience for an agrophobic.

To get to the teleports, you have to jump between platforms suspended in orbit around the planets. On the way, you'll encounter various meanies. Zub's method of dealing with these is simple - run away terribly fast.

It's on the Mastertronic MAD label, and promises oodles of animation, hi-res attributes and amazo parallax!



Our hero bounding around above planet Z

A SPOT OF BOWVER WITH THE WEEDKILLER

Agent Orange comes to you from those paragons of good taste at **A'N'F SOFTWARE**. The name comes from that rather nasty stuff they used to spray all over Vietnam to destroy the undergrowth and make 'Charlie' easier to spot. The only trouble is that vegetation takes years to recover from it, and the chemical is highly toxic and carcinogenic.

But never let details like that stand in the way of a good idea for a computer game. This one is all about destroying enemy harvests, to be fair, he's busy doing the same to you in this arcade/strategy game. The aim is to destroy the enemy by starvation. Both players are trying to damage as much of the enemy harvest as possible, whilst ensuring that their own is both protected, and gathered in when ready. The crops grow in 'life' style, ie there is an

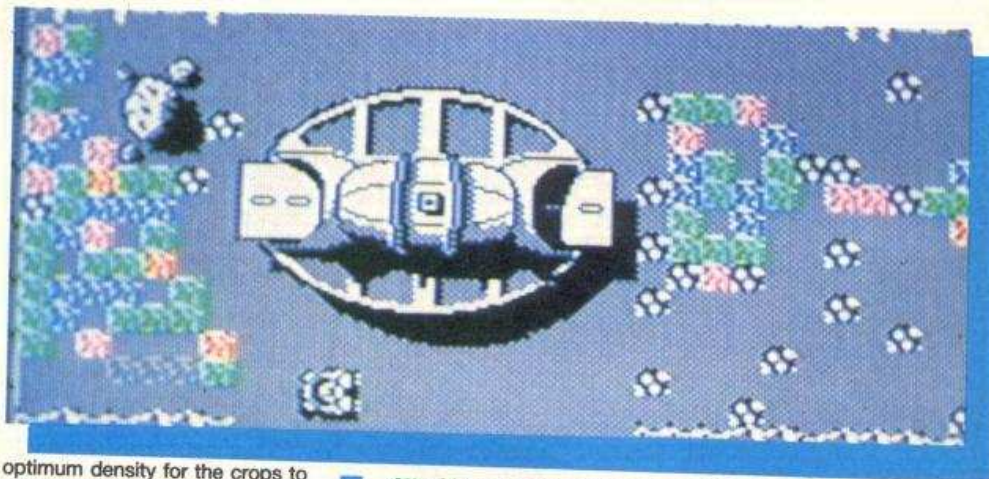

optimum density for the crops to grow quickly, too sparse or too packed and they wither away.

Attacking an enemy industrial complex. Try to do as much damage as possible, but look out for signs of enemy attack

TAKING LESSONS AT THE ACADEMY

The long awaited sequel to *Tau Ceti* is nearly here. Pete Cooke is back in top form with this game, proving that *Room 10* was nothing more than a quick pot-boiler.

The core of the game will be familiar to all *Tau Ceti* freaks, but this game has so much more! The 'front end' of the program features a menu driven system which allows you to design your own ship. This includes the usual add-bits-on-to-the-ship segment, but there is also a revolutionary section where you design your own screen layout! This may well be the start of a new era in games design, hopefully everyone will soon be allowing you to do this.

Another added dimension is the

final object of the game. There are five levels, each containing four missions. Each mission requires different qualities and contains different hazards. Once you have managed to obtain good marks in all four missions, you can progress on to the next level.

In case you still think that you're not getting value for money, Pete has thrown in a astronomy program for nothing. This allows you to scroll around the milky way, with zoom and pan, as well as being able to find named stars and show up constellations

It's on the way from CRL and should be here by the time you read this.

A hectic time in *ACADEMY* as one meanie gets his comeu pance but another is still blasting away



"GAMES AT THE SPEED OF LIGHT..."

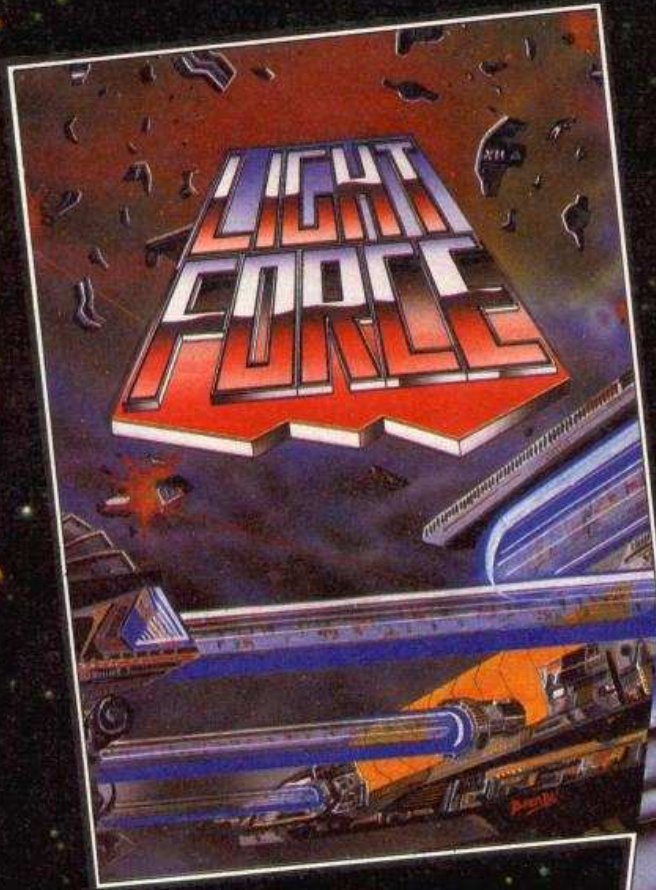

LIGHTFORCE is for **VENGEANCE**.....
LIGHTFORCE is the Punishment Arm of Galactic Fighter Command.

When a Terran-settled system at the edge of the galaxy is seized by an alien force, revenge comes in the form of a lone **LIGHTFORCE** fighter.

LIGHTFORCE confronts alien in a dazzling battle above the strange landscapes of the Ice-Planet, the Jungle Planet, Alien factories and the impassable Asteroid Belt.

LIGHTFORCE — at the speed of Light - from **FTL**.

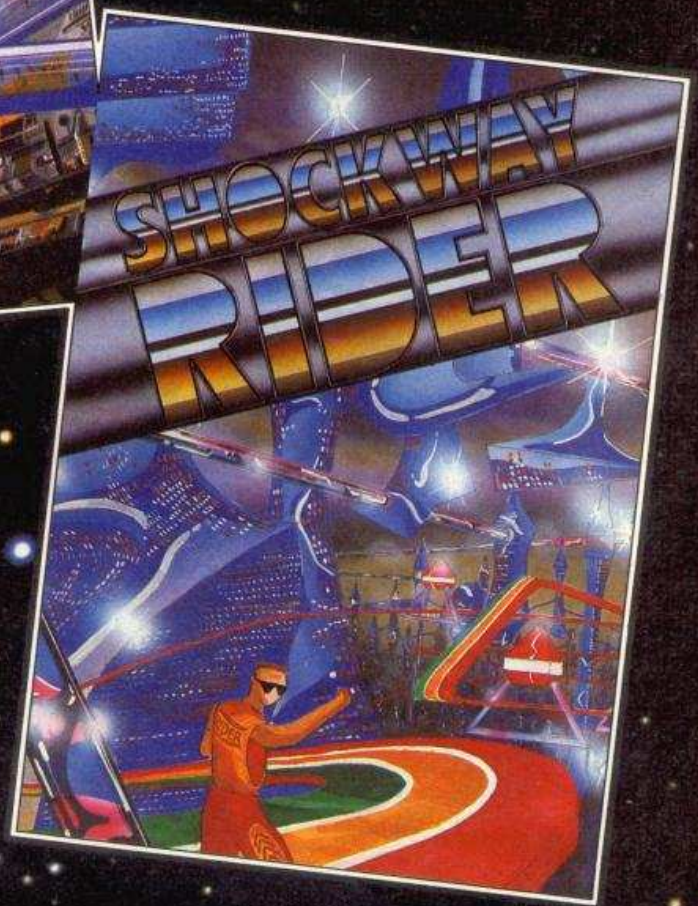

SHOCKWAY RIDERS are the pick of the street gangs - **ATHLETIC, AGGRESSIVE & ARROGANT** - as they cruise along the triple-speed moving walkways that circle the great **MEGACITYS** of the 21st Century. **THE ULTIMATE AIM OF EVERY RIDER** is to go "**FULL CIRCLE**" - to do that, he must fight off the Block Boys, the Cops and the Vigilantes - as well as negotiating the Speed Traps and Rider Ramps erected by the angry local residents!

SHOCKWAY RIDER is the most original arcade game of the year - **THE ULTIMATE FUTURE SHOCK!!**

FTL
FASTER THAN LIGHT

LIGHTFORCE AVAILABLE SEPT. '86

SPECTRUM £ 7.95
 AMSTRAD & COMMODORE £ 8.95

FTL FASTER THAN LIGHT, CARTER FOLLIS GROUP OF COMPANIES,
 SEDGLEY ROAD EAST, TIPTON, WEST MIDLANDS DY4 7UJ. Tel: 021-557 2981 (4 lines)

STARGLIDER READY FOR TAKE OFF

Novenia is having a slight problem, it has got rather more Egron invasion ships than it really needs. Actually, one Egron invasion ship is too many, so the twenty odd space ships packed with tanks, fighters, stompers, cannon and missile batteries which are threatening the planet are just too much of a bad thing.

It is a particular shock to the inhabitants of Novenia who thought their space defense system, the Sentinals, were totally impenetrable. Indeed, they've thought this for quite a long time. This means they've done away with all those nasty armies, planes and ships, in short, just the sort of things that would come in really handy right now. In *Starglider* from RAINBIRD, you take the part of Jaysan who discovers a clapped out old fighter plane at an abandoned old airfield and decides he must rid the planet of the Egron menace single-handedly.

Just in case you thought from all that lot that it was going to be just another shoot em up, let's put you straight. RAINBIRD claim that this is the first game for the Spectrum ever to feature animated vector graphics with full hidden line removal. Each level consists of a huge area; 100 distance units along each side, giving a vast playing area on which to hunt down the marauding invaders.

The game gives a cockpit view of the landscape of Novenia. It is packed with a grand total of 18 different types of meanie. You're armed with lasers and a couple of missiles. The object of the game is to wipe out the aliens. Some are sitting ducks, and will just take a quick burst of laser fire to dispose of. Others are far more manoeuvrable, and will either hurtle through the sky or scuttle around the ground. If he wants to survive, the young defender of all things Nove-

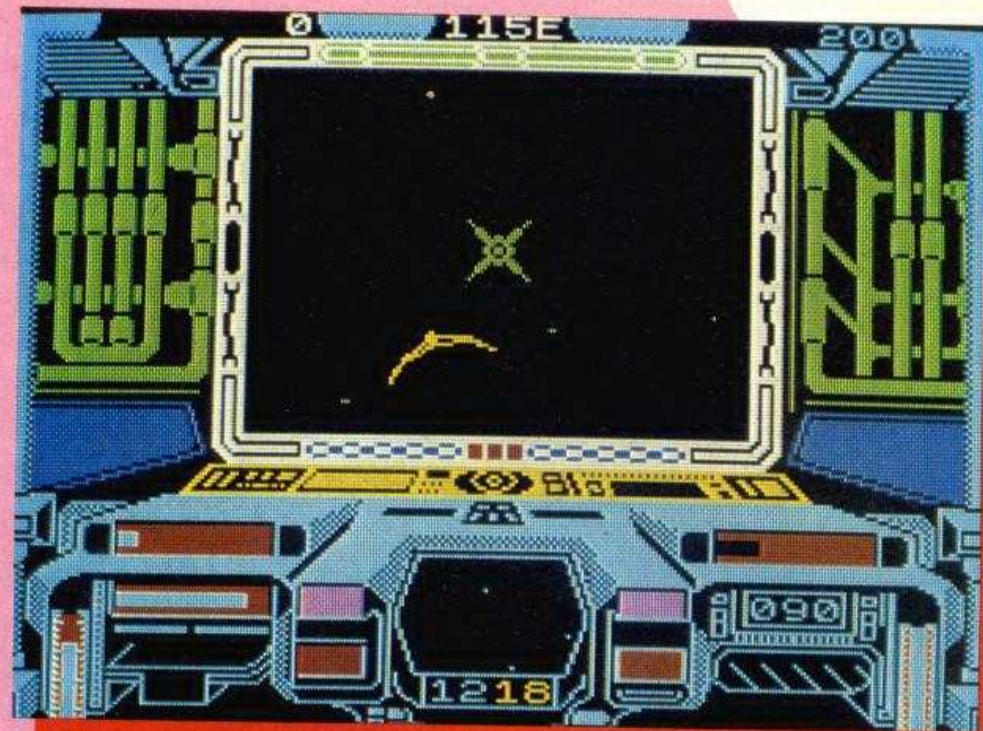

Stargliders are only hurt by missiles, so launch one. Now you are looking from the camera onboard the missile, guiding it to its target

nian must learn to quickly recognise these types of ships and work out how to deal with them.

Some enemy ships are only susceptible to missiles. When you hit the missile button, the screen changes, and you are looking from the missile using an on board camera as you guide the missile to its target. After a number of seconds the missile runs out of fuel, so its up to you to guide it to its target

before your precious missile drops harmlessly to the ground. You can only carry two missiles at the most. You get more by docking with missile silos. These missile silos however, only manufacture weapons at a fairly slow rate, so it pays not to waste them. Once you've scored 10,000 points, its off to the next level.

According to RAINBIRD, a 128k

version is planned which will feature synthesised speech and special missions. When this game was written on the Atari ST, it was designed to show off that machine's incredible graphics ability and speed. The Spectrum version just goes to show that anything the 16 bit big boys can do, the good old speccy can do nearly as well at a fraction of the price!

A huge alien Starglider fires at you as you dive towards it.



Fuel is getting low, so head for the towers to refuel. But watch out for the tank and missile silo



KEVIN'S THE KING OF STRATEGY

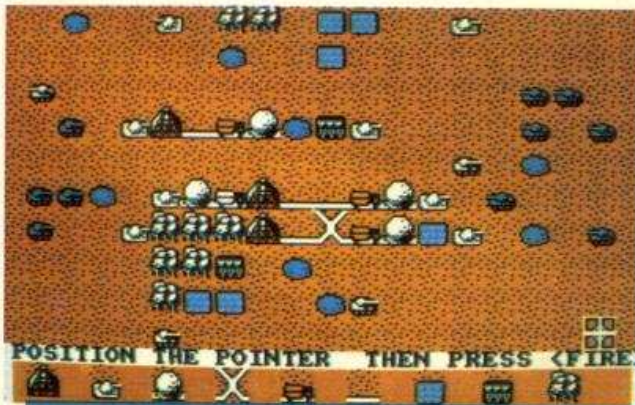

The country appears to be thriving, but look out for the enemy invading from the east

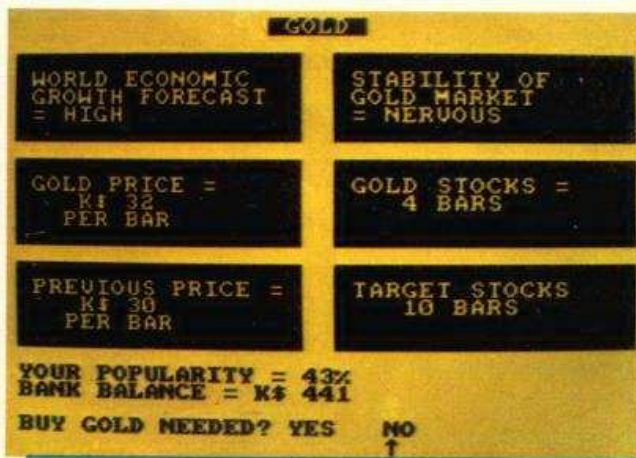

One of the economic screens, but watch the popularity, 43% is dangerously low!

Contrary to popular belief, Kevin Toms hasn't been resting on his laurels since *Football Manager*, he's been hard at work on his opus magnum - *President* - and from what we've seen of it, it promises to be the king of the 'King' games.

At the start of the game, you start with an entirely blank screen, a desert. From this humble beginning, you must raise a rich and prosperous land, full of happy, contented people. The first task is to do a seismological survey for oil. Then, on the basis of this, sink oil wells. Then you must construct a distribution system. This consists of oil storage depots, roads, and trucks.

Of course, all this development is going to mean that the population is going to increase fairly quickly. And it's up to you to feed them. This involves planting crops and irrigating them. All this sudden activity produces an upsurge in interest from neighbours who cast envious eyes on your wealth. So

this means that the old army has to be kept up to scratch, otherwise someone else is going to reap the benefit of all your hard earned wealth.

Obviously, committing resources and people to the army is going to put a strain on the economy, and the game has a very strong economic flavour. Such diverse subjects as gold reserves, the world price of oil and public expenditure must all be coped with if the country is to thrive.

Every three years, the President has to face re-election. With the monthly report, you will get an indication of your popularity with the people, and thus your chances of re-election. So a little timely increase in public expenditure might be required to grease the wheels of politics

ADDICTIVE games say the game should be out around the end of November. Just in time for every strategy fans Xmas stocking.

STOMP STOMP BALM BLAM ARGHHHHH

Commando no problem huh? Looking for more of a challenge, well, it looks as if *ELITE* might have done it again with *Ikari Warriors*, which takes the basic style of *Commando* and puts a lot more variety and gameplay in.

Once again, you play a lone, highly trained combat soldier, pitted against the might of the ruthless enemy. Fortunately, there is a little bit more equipment around

trusty machine gun. Be careful though, as you've got a finite amount of ammo and it's easily wasted. Luckily though, there's usually plenty lying about.

In this faithful adaption of the arcade game, the player can toggle between multi-direction mode and vertical firing. With vertical firing, no matter what direction the man is moving in, the bullets always fire straight up. In multi

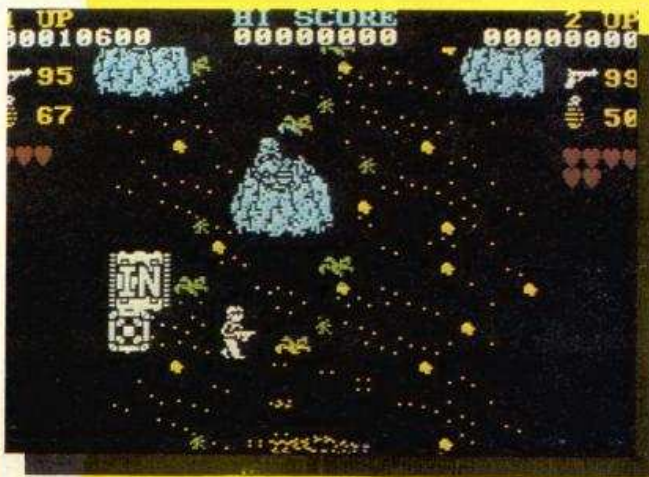

Your tank awaits you Sir! Our hero is about to take to his treads - a lot safer than on foot with all this high calibre stuff flying around

this time. Not only can you pick up grenades and ammo, there is also the odd tank lying around, engine running and keys in the ignition. So jump in the turret and off you go. But be careful, if the tank gets hit by bazooka fire, you've got to bail out in a hurry. Then it's back on foot and blazing away with the

direction mode, the bullets ripple off in the same direction as the player is moving.

Our hero must battle his way past gun emplacements, over bridges and through the perilous jungle. Looks like the sort of game that *Commando* fans will want to storm their local software shop for

Looks like curtains for our man as the baddies close in from all sides at the end of the first stage

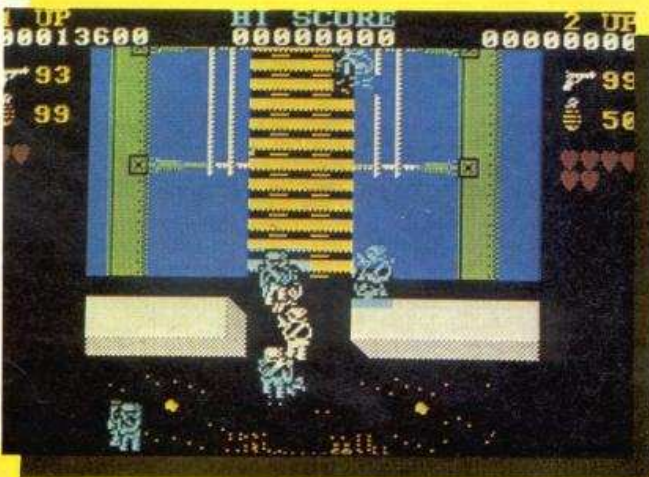

PREVIEW

LITTLE THINGS PLEASE LARGE SPECCY'S

Little Computer People finally looks as though it's going to make it to the Spectrum, well, the 128 Spectrum anyway. Our spy, (just try stepping lightly in Doc Marten's) sneaked down to ACTIVISION's H.Q. in Hampstead to take a look. Apparently, scientists at Amstrad trying to get the bugs out of the new plus 2 have discovered that it's nothing to do with processor incompatibilities, or undocumented system calls, but to little chaps actually living inside the machine. The idea of this program is to provide a nice, pleasant environment which will tempt the little chap out of the cramped confines of the PCB and on to the computer screen.

Once you have tempted the

chappie out on to the screen, you have to gain his confidence. To do this, you must make sure he keeps fed and watered and that he takes regular exercise. Along with this you must provide him with entertainment. This comes in various forms, software for his home computer, books to read and records for his stereo.

The little chap takes exercise, feeds his dog, and talks to you. Sometimes he'll challenge you to a game of cards, speculate on the meaning of life or play the piano.

Trying to build up a meaningful relationship with a computer sprite is obviously going to bring a whole new dimension to owning a Spectrum. ACTIVISION hope the game will be around by mid November.

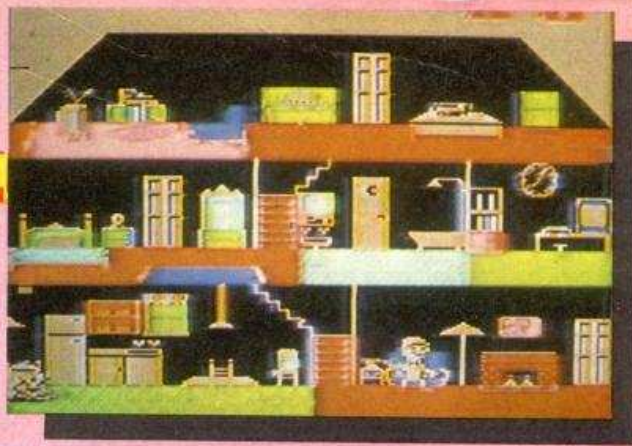

Fred the little computer person puts his feet up by the fireside, time for a little back scratching?

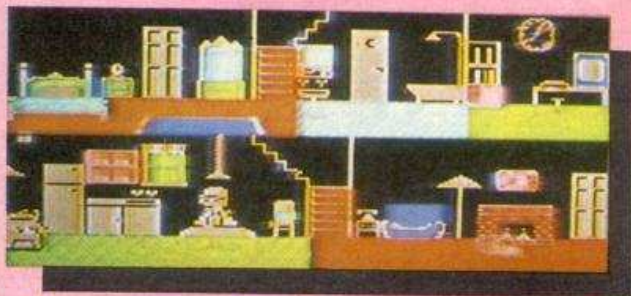

Fred's a regular card shark. Here he is taking young Mr Kidd for a ride. I wondered why the Doc Martened one came back shirtless

WATCHER OF THE SKIES

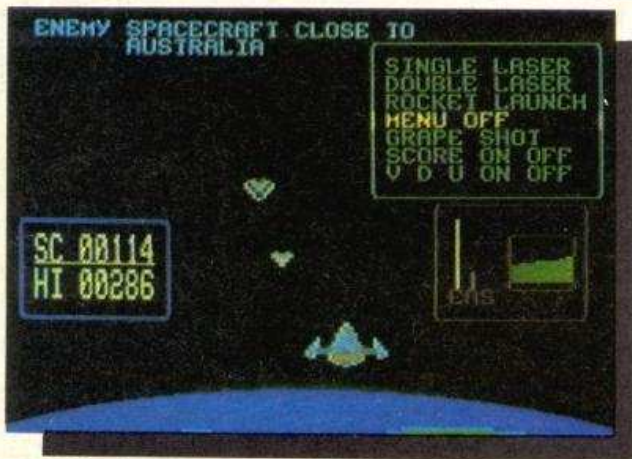

A tricky situation, can you save Australia (do you want?)

From those lovers of subtle game play at QUICKSILVA, for a mere £8.95, comes Defcom. This is an all action shoot-em-up. It is set near Earth after the setting up of Ronnie's beloved star-wars system. The trouble is that the aliens have taken it over, and are now bent on Earth's destruction.

You play the hero (surprise, surprise!) who has to control a star-

ship, disarm Earth bound missiles, and blow up satellites and the alien attack force - and all of this before breakfast!

The player must respond to calls from help from various cities and then get into position to stop the alien missile attack. This promises to be another good blaster with smooth graphics and fast game play.

VERY FIENDISH ORIENTAL STRATEGY

Before you all throw up your arms in horror, don't worry, Samuri isn't yet another Way Of the Exploding Fist clone. This is an oriental strategy game all about the ancient honourable order of the Samuri going around beating each other up.

The first thing you must do is select your army. There are three scenarios presented, each of these will involve different computer controlled opposition, and so you will be given a different number of selection points to build an army with. There are four diffe-



Looks like the computer is ganging up to give ace snapper Cameron a tough time here. Stick to the shoot-em-up's Cam

rent types to choose from. Slow, plodding Ashigaru, faster but lightly armed Ninja, Samuri infantry, and lastly, Samuri cavalry, and jolly nasty they are too.

Having selected your lads, the game moves to the battlefield, where you've got to wipe out the enemy hordes. Depending on the scenario chosen, you will either be attacking or defending the sacred temple. Winning the game is all about killing the computer's men before he does the same to you - simple really! This is achieved by making sure that in any little punch up, there are more of your men there than his. To do this, you must take advantage of the terrain. Some bits of background are more difficult to move through than others. Each type of soldier has a certain movement and combat rating. Ninjas have a further advantage, they can hurl projectiles at long ranges without making themselves vulnerable to attack.

The game is controlled with a

series of icons at the bottom of the screen. When it's your turn, the computer gives you the opportunity of moving each one of your men. It tells you how mobile the bloke is, and what his present combat strength is. One useful icon allows you to have a quick look around the landscape to check where help is most needed, or to spot a bunch of meanies just about to attack; if you haven't got many men there then run away!

There is plenty of colourful graphics and generally the presentation seems well above standard for this sort of game. Published by CRL, hopefully it'll be out before Christmas and might make a few converts of people who had previously steered well clear of strategy games. This seems pretty easy to get into, with lots of icons to smooth things along, although it might not quite have the speedy action that the arcade fraternity crave for.

THE ULTIMATE ROLE PLAYING FANTASY GAME



Valkyrie the Valkyrie, beautiful and fearless, she is protected in combat by strong armour.



Questor the Elf, impish and cunning his deadly accuracy and unbelievable speed make him a formidable foe.



Thor the Warrior, bold and brave, there can be none to match his skill in hand to hand combat.

Merlin the Wizard, mystical and wise, the power of his magic is untold.

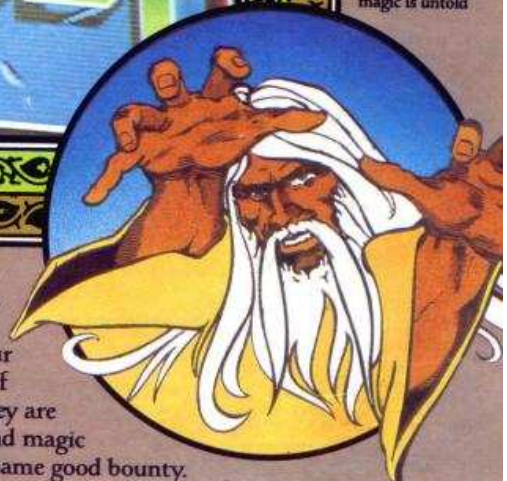
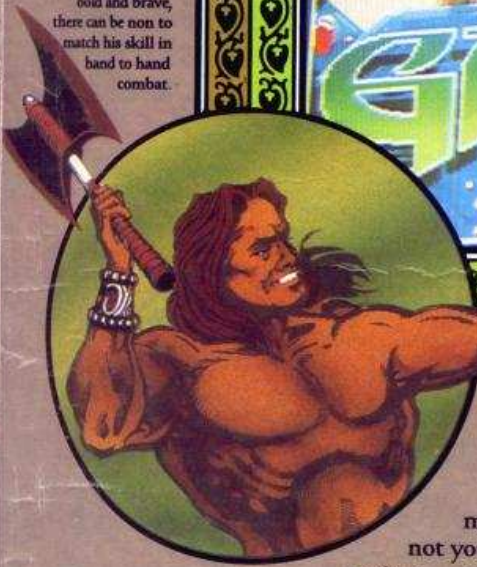

Enter the world of monsters and mazes. Travel the path of mystery and combat in search of the food that replenishes your 'health'. Your way is barred by an array of monsters and legions of enemy beings but they are not your only foe in the quest for food, treasure and magic potions - your fellow players compete in search of the same good bounty.



TAPE

CBM 64/128, Amstrad,
Atari £9.99
MSX

Spectrum
£8.99

DISK

CBM 64/128, Amstrad,
Atari £14.99

Amiga/Atari ST, IBM
£24.99



TM and © 1985 by Atari Games Licensed to U.S. Gold



GAUNTLET™



U.S. Gold Ltd., Units 2/3 Holford Way,
Holford, Birmingham B6 7AX. Tel: 021 3563388



From a
NEW NAME IN COIN-OP
 COMES
IKARI WARRIORS
 By SNK Corporation



Spectrum	Cassette	£7.95
Amstrad	Cassette	£8.95
Amstrad	Disc	£14.95
Commodore	Cassette	£9.95
Commodore	Disc	£14.95
C16	Cassette	£7.95

Mail Order, just send a cheque or postal order payable to Elite, or quote your Credit Card number.



Elite Systems Ltd.,
 Anchor House, Anchor Road, Aldridge,
 Walsall, West Midlands, WS9 8PW.
 Telephone: (0922) 59165.
 Telex: 336130 ELITE.G. Fax: (0922) 647358

**Simultaneous
 2-Player Option!!***

*Adding an exciting new dimension to gaming - "Ikari Warriors" allows one or two player simultaneous play. (Note: This format may vary with computer format.)

The very best Elite Titles are available at selected branches of:

-  WHSMITH, Tandy
-  John Menzies
-  LASERS



Screen shots shown from various machine formats.

elite